

# General Catalogue 2013



**ACL**





**This general catalogue has been committed to :**

**Mrs/Mr** \_\_\_\_\_

**Company** \_\_\_\_\_

**address :** \_\_\_\_\_

**on date** \_\_\_\_\_

**by our** \_\_\_\_\_

**EDITION EN 01/13**



<b>GENERAL INFORMATIONS</b>	<b>1</b>
<b>2/2 DIRECT ACTING SOLENOID VALVES</b>	<b>2</b>
<b>3/2 DIRECT ACTING SOLENOID VALVES</b>	<b>3</b>
<b>2/2 SERVO-ASSISTED SOLENOID VALVES</b>	<b>4</b>
<b>SOLENOID OPERATED PINCH VALVES</b>	<b>5</b>
<b>SOLENOID PILOTS</b>	<b>6</b>
<b>COILS</b>	<b>7</b>
<b>ACCESSORIES</b>	<b>8</b>
<b>SPARE PARTS</b>	<b>9</b>



**1.1 Introduction****1.2 Type number composition****1.3 Construction details****1.4 Seal material****1.5 Media compatibility****1.6 Electrical features**

1.6.1 Protection class

1.6.2 Insulation class

1.6.3 Service

1.6.4 Power

**1.7 Units of measure****1.8 Flow calculation****1.9 Technical tables**

1.9.1 Pressure

1.9.2 Viscosity

1.9.3 Temperature

1.9.4 Steam

1.9.5 Specific gravity

**1.10 Response time****1.11 P.E.D. Directive (97/23/EC)****1.12 Operating instructions and installation****1.13 Model identification**





## 1.1 Introduction



1

The solenoid valves illustrated in this catalogue have applications in all industrial sectors, being compatible with a vast range of fluids.

The quality of the materials used and the precise engineering of the parts, coupled with rigorous testing of the large production guarantees their service capability.

In addition to the standard versions illustrated here, we are able to offer alternative designs to resolve specific problems.



## 1.2 Type number composition for servo-assisted versions

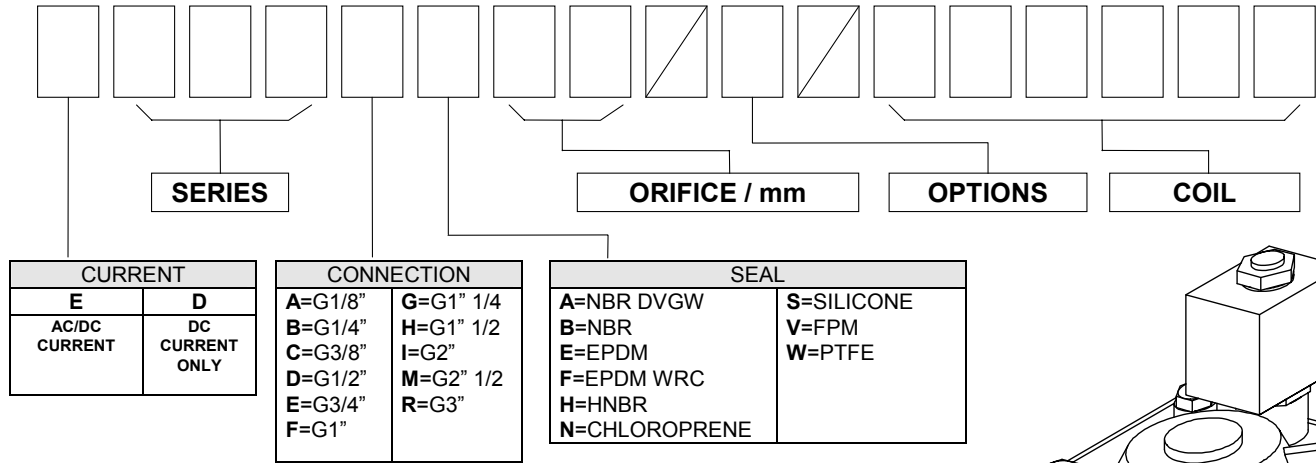

1

Example :  
**E207IV50///20E**

Solenoid valve suited to work in alternative or direct current 2/2 normally open, 2" BSP connections, FPM seal, orifice 50 mm, coil width 30mm, class F insulation, power consumption 15VA, voltage 220-230V 50/60Hz.

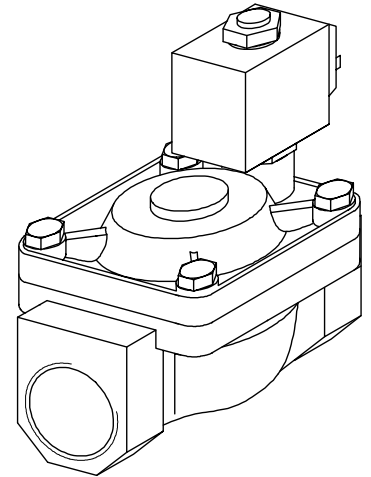

## 1.2 Type number composition for direct-acting versions

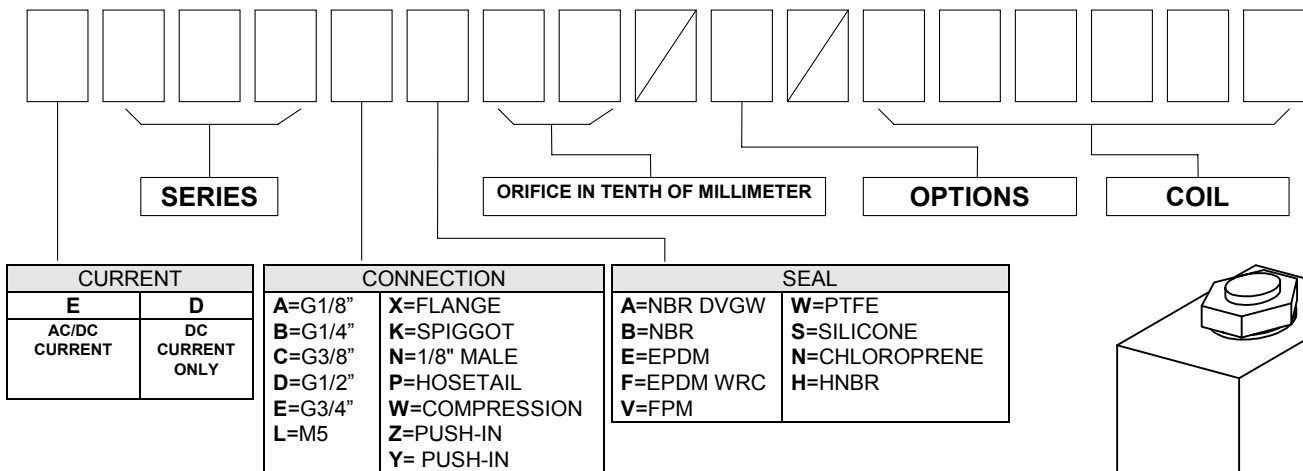

Example :  
**E105AB15///301**

Solenoid valve suited to work in alternative or direct current 2/2 normally closed, 1/8" BSP connections, NBR seal, orifice 1,5mm, coil width 22mm, class F insulation, power consumption 6,5W, voltage 24V DC.

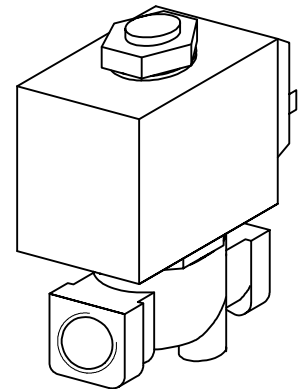

## 1.2 Type number composition for coils

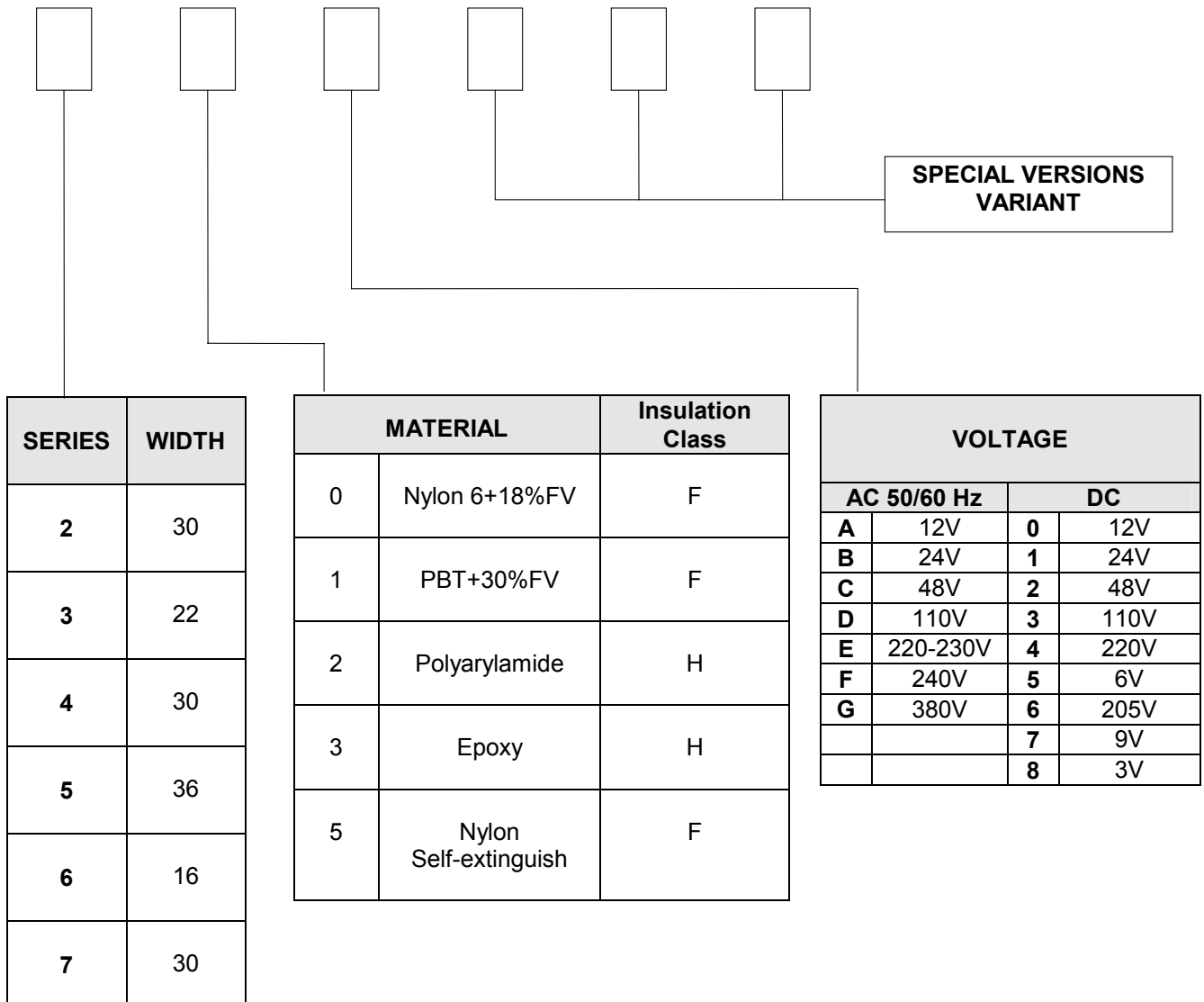

Example :            30B  
 Coil width 22 mm in Nylon 6+18% Fibre Glass  
 Insulation class F Voltage 24V 50/60Hz power 8VA

## 1.3 Construction details

Solenoid valves are equipments to control media in pressure. Their action is to either open or close the interception device, directly or indirectly, when the coil is energised.

**1**

The most important components of the solenoid valve are :

1. The **body valve**, which has an inlet and an outlet connection and an orifice for media flowing.
2. The **armature tube**, with the core, where the coil is fitted.
3. The **plunger**, which in some cases serves like a seal, sliding in the armature tube.
4. The **coil**, which produces the magnetic field required to move the plunger.

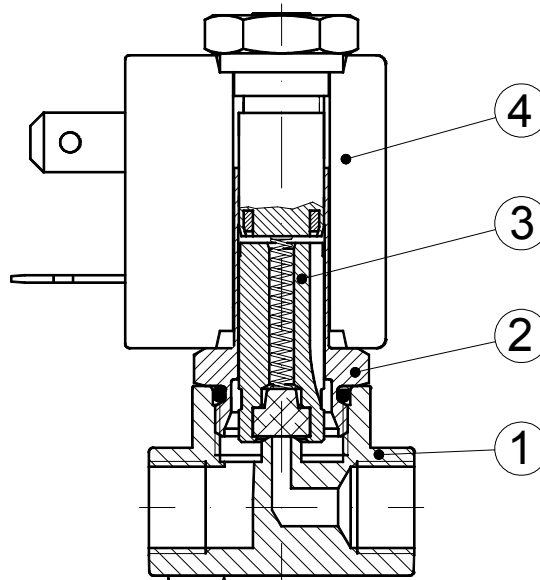

## 1.3.1 Methods of operation

### 2 way direct-acting

The 2 way solenoid valve has an inlet and an outlet connection within the valve body.

It can be **normally closed** (2/2 NC). In this case the media is prevented from flowing through the orifice by the plunger seal. When connected to an electrical supply, the orifice opens allowing the inlet to feed the outlet port.

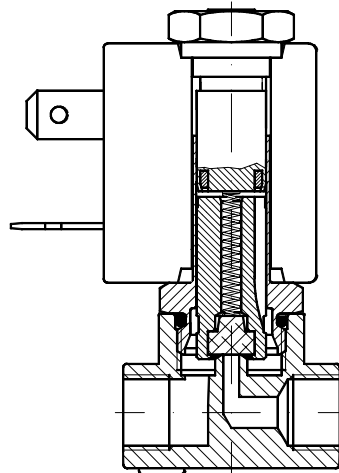

It can be **normally open** (2/2 NO). In this case the orifice is open, the inlet feeds through the outlet. When connected to an electrical supply the orifice is closed. The operation, in both cases depends only on the magnetic field produced by the coil. These solenoid valves are able to work at **zero pressure**.

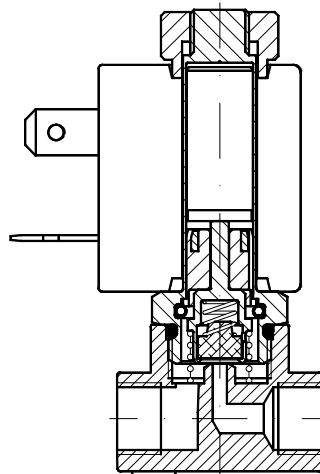

### 3 way direct-acting

The 3 way solenoid valve has inlet and outlet connections in the body and an exhaust connection above the core.

It can be **normally closed** (3/2 NC). In this case the media is prevented from flowing through the inlet orifice by the plunger seal. The inlet and exhaust orifices are at each end of the plunger. When connected to an electrical supply, the inlet orifice opens feeding the user port. The exhaust is closed.

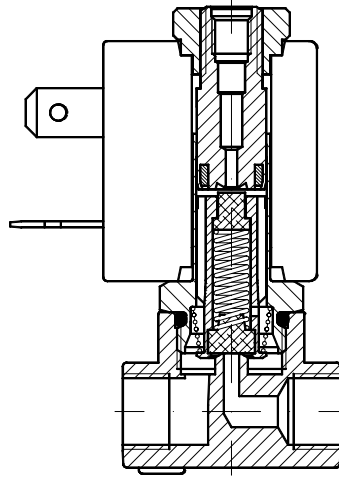

It can be **normally open** (3/2 NO). In this case when the coil isn't energised the inlet orifice is open to the user port. Exhaust port is closed. When connected to an electrical supply, the inlet orifice closes, at the same time the exhaust port is opened and connected with the user port.

In both cases, the operation depends only on the magnetic field produced by the coil.

These solenoid valves are able to work at **zero pressure**

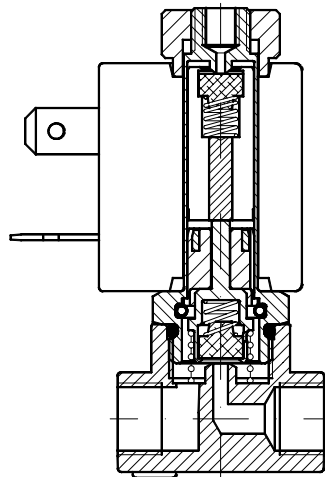

### Servo-assisted action

With larger orifices, static pressures increase, and it's still necessary that the magnetic field produced by the coil is able to control these forces. This is achieved by using servo-assisted action in the solenoid valve.

In this design the media pressure helps to keep the main valve seal closed.

**The normally closed** design (2/2 NC) has an inlet and outlet connection in the valve body. When the coil is not energised, the flow is blocked by the main seal, which could be either a diaphragm or a piston design. In this mode the media flows through a small hole in the diaphragm or piston and helps close the valve. When the coil is energised the pilot orifice opens, allowing the media above the main seal to exhaust and the main valve seal to open.

This type of solenoid valve needs a minimum differential pressure to work.

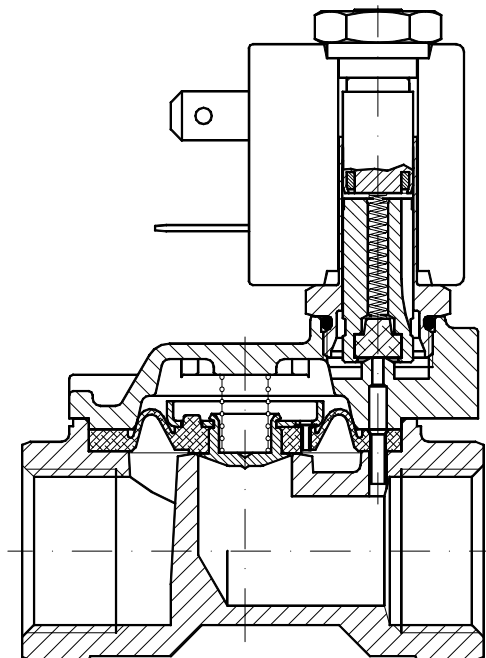



The **normally open** (2/2 NO) version has an inlet and outlet connection in the valve body. With larger orifices, static pressures increase, and it's still necessary that the magnetic field produced by the coil is able to control these forces. This is achieved by using servo-assisted action in the solenoid valve. In this design the media pressure helps to keep the main valve seal open. When the coil isn't energised, the flow is not interrupted by the main seal, which could be either a diaphragm or a piston design. In this mode the media flows through a small hole in the diaphragm or piston and helps the valve to open. When the coil is energised the pilot orifice closes, allowing the media above the main seal to pressurise and the main valve seal to close.

This type of solenoid valve needs a minimum differential pressure to work.

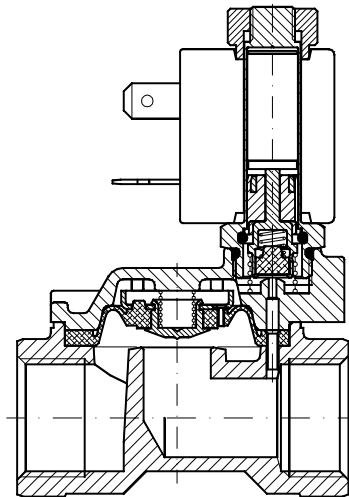

They are available with an **assisted lift** design pilot operated by diaphragm and **normally closed** (2/2 NC). In these models the plunger is mechanically attached to the diaphragm and controls the central pilot orifice and the stroke of the main seal.

This design allows the valve to work at zero differential pressure.

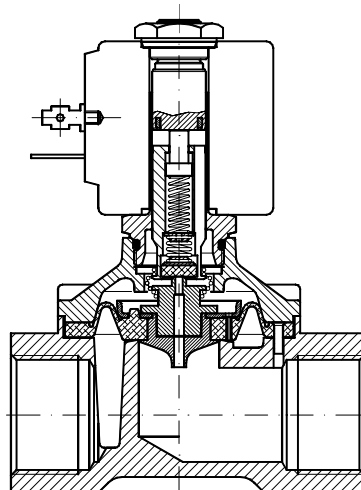

## 1.4 Seal materials

Designation	Commercial denomination	General characteristics	Typical application
NBR (Acrylic-nitrile butadiene)	BUNA -N PERBUNAN ELAPRIM JSR-N	A synthetic elastomer with good mechanical and thermal properties. Good resistance to oils. Poor resistance to ozone and atmospheric derivatives.	Water with a max. temperature 70°C, air with a max. temp.90°C. Mineral oils and their derivatives, hydrocarbons, methane, ethane, propane, butane, kerosene oil, fuel oil.
EPDM (Ethylene-propylene-dylene )	BUNA- AP DUTRAL NORDEL	A synthetic elastomer derived from the co-polymerization of ethylene and propylene. Suitable for use with non-phosphoric based hydraulic fluids(hold). Water and steam to a max. temp of 140°C. Not suitable for use with mineral based products. (oil, grease , fuel oils and petrol)	Hot water and steam. Detergents. Potassium and sodium solutions. Hydraulic fluids. Polarised solvents. Skydrol 500 and 700 *
FPM (Fluorocarbon)	VITON TECNOFLON FLUOREL	A synthetic elastomer derived from flour-propylene. Excellent resistance to the high temp. Excellent resistance to ozone, oxygen, mineral oils, synthetic hydraulic oil, petrol, hydro-carbons and many other chemicals. Not suitable for use with superheated steam.	For general use up to 130°C
PTFE (Polytetrafluorethylene)	TEFLON	Thermoplastic material used also filled with a mineral resin. Excellent resistance to many chemicals. Optimum high temp. resistance. Poor resilience, improved by adding the mineral filling.	For general use up to 160°C

\*Warning: not to be used with mineral oils and grease

## 1.5 Media compatibility

The following table has the scope to provide an indication of the general characteristics with regard to the compatibility with the different materials and media.

To determine the compatibility with corrosive fluids it is important to know all the data relative to :  
temperature, concentration and media composition.

1

MEDIA	Brass	Stainless Steel	NBR	EPDM	FPM	PTFE
Acetone	•	•	-	•	-	•
Acetylene	•	•	-	•	•	•
Argon hold	•	•	-	•	•	•
Benzol	•	•	-	-	-	•
Butane	•	•	-	-	•	•
Calcium monoxide	•	•	•	•	•	•
Carbon dioxide (liquid)	-	•	-	-	-	•
Carbon disulphide	•	•	-	-	-	•
Chloroform	•	•	-	-	-	•
De-ionised water	-	•	•	•	•	•
De-mineralised water	-	•	•	•	•	•
Dry carbon dioxide (gas)	•	•	•	•	•	•
Ethane	•	•	•	-	•	•
Ethanol	•	•	-	-	-	•
Ethyl acetate	•	•	-	-	-	•
Ethyl chloride	•	•	•	•	•	•
Ethylene glycol	•	•	•	•	•	•
Formaldehyde	•	•	•	•	•	•
Freon	•	•	-	-	-	•
Fuel oil	•	•	•	-	•	•
Glycerine	•	•	•	-	•	•
Hard water	•	•	•	•	•	•
Helium	•	•	•	-	•	•
Heptane	•	•	•	-	•	•
Hexane	•	•	•	-	•	•
Hot water <75°C	•	•	•	•	•	•
Hot water and steam <140°C	•	•	-	•	-	•
Hydrogen	•	•	-	-	•	•
Hydrogen dioxide	-	•	-	-	•	•
Isobutane	•	•	•	-	•	•
Isopentane	•	•	•	-	•	•
Methane	•	•	•	-	•	•
Methanol	•	•	-	•	-	•
Methyl chloride	•	•	-	-	-	•
Mineral oil	•	•	•	-	•	•
Natural gas	•	•	•	-	•	•
Neon	•	•	•	-	•	•
Nitrobenzene	•	•	-	-	-	•
Nitrogen	•	•	•	•	•	•
Oxygen	•	•	•	-	•	•
Pentane	•	•	•	•	•	•
Petrol	•	•	-	-	•	•
Propane-n	•	•	•	-	•	•
Soapy water	•	•	•	-	•	•
Toluene	•	•	-	-	•	•
Trichlorethylene dry	•	•	-	-	•	•
Vinegar	•	•	-	•	-	•
Water with glycol	•	•	-	-	•	•
Xilol	-	•	-	-	•	•

• Compatible

- Not compatible

## 1.6.1 Protection class IP.....

Compliance with the standard DIN 40050 for the electrical protection at 1000 Volt AC and 1500 Volt DC.

1 <sup>st</sup> number : protection against solid bodies			2 <sup>nd</sup> number : protection against liquids			3 <sup>rd</sup> number : mechanical protection		
IP	Testes	Description	IP	Testes	Description	IP	Testes	Description
0		No protection	0		No protection	0		No protection
1	Ø52.5 mm	Protection against solid bodies larger than d.50 mm (ex. involuntary contact by hand)	1		Protection against the vertical fall of water drops (condensation)	1		Impact energy 0.225 joules
2	Ø12.5mm	Protection against solid bodies larger than d.12mm (ex. finger contact)	2		Protection against the fall of water drops up to 15° from the vertical	2		Impact energy 0.375 joules
3	Ø2.5mm	Protection against solid bodies larger than d. 2,5mm (ends of tools, wires)	3		Protection against the fall of water drops and rain up to 60° from the vertical	3		Impact energy 0.500 joules
4	Ø 1 mm	Protection against solid bodies larger than d. 1 mm (ends of tools, thin wires)	4		Protection against water jets from all directions	4		Impact energy 2.00 joules
5		Protection against dust (no harmful deposits)	5		Protection against forced water jets from all directions	7		Impact energy 6.00 joules
6		Total protection against dust	6		Protection against water similar to waves	9		Impact energy 20.000 joules
			7		Protection against water immersion			

In the case of the solenoid valve, use only the first two numbers

## 1.6.2 Insulation class (or temperature class) according to CEI 15-26

Insulation class	Temperature °C
Y	90
A	105
E	120
B	130
F	155
H	180
200	200
220	220
250	250

1

The indicated temperature is the effective temperature of the insulation and not the over temperature.

## 1.6.3 Service

The coils are normally expected to be used in continuous service (ED100%).

Definition of “Continuous service”: when the electrical connection time exceed the thermal constant of the coil by approx. 1/4 .

As a general rule, the continuous service corresponds to an electrical connection time that is equal or higher than 15 minutes.

It's possible, for non-continuous service (e.g. ED50%), either to have coils at powers that are higher than the standard ones, or to use the coils with an ambient temperature higher than the ones indicated.

$$ED = \frac{\text{connection time}}{(\text{connection time} + \text{disconnection time})} \times 100$$

**EXAMPLE :** 
$$\frac{5' (\text{connection time})}{5' (\text{connection time}) + 5' (\text{disconnection time})} \times 100 = ED50\%$$

## 1.6.4 Coils power

The power (P) indicated is referred to a temperature of 20°C.  
For DC current it is as follows:

$$P(\text{watt}) = V(\text{Volt}) \times I(\text{Ampere}); \quad P = \frac{v^2 (\text{Volt})}{R (\text{Ohm})}$$

In the case of AC current, the value is referred to the apparent power during inrush (connection moment) and during holding.

$$P(\text{VA}) = V(\text{Volt}) \times I(\text{Ampere})$$

In the case of AC current, voltage and current are not in phase with each other. Phase angle between current and voltage is shown by the angle  $\varphi$  of the resistance triangle (the three sides represent: resistance, reactance and impedance of the circuit).

In the case of AC current the power showed in Watt become:

$$P(\text{watt}) = V(\text{Volt}) \times I(\text{Ampere}) \times \text{power factor } \varphi$$

power factor  $\varphi$  = power factor is always less than 1

The power, or electric input, in a AC current solenoid valve, is higher during inrush while it decreases when the plunger's stroke is complete.

In the DC current solenoid valve, as the power depends from the coil's Ohmic resistance, the power is the same during inrush and also when the plunger's stroke is complete too.

### 1.7 Units of measure

In the international system (SI) the physical and technical units are validated as follows :

Unit of length	:	Meter	(symbol m)
Unit of mass	:	Kilogram	(symbol Kg)
Unit of time	:	Second	(symbol s)
Unit of electrical current	:	Ampère	(symbol A)
Unit of temperature	:	Kelvin	(symbol K)
Unit of luminosity	:	Candle	(symbol cd)

#### Pressure

Old measuring units :

Kilopond per cm <sup>2</sup>	Kp/cm <sup>2</sup>
Meter of water column	mH <sub>2</sub> O
Millimeter of mercury column	mmHg
Metric Atmosphere	at
Atmosphere	atm

They were replaced in the SI from Pascal.

One Pascal corresponds to the pressure of 1 Newton, which is acting on the area of 1 m<sup>2</sup>.

$$1 \text{ Pascal} = \frac{1 \text{ N}}{1 \text{ m}^2} \text{ (symbol Pa)}$$

Unit Pa is a very low value and for standard industrial applications, the Bar (symbol bar) is used.

1 bar = 0.1 MegaPascal (symbol Mpa=1.000.000 Pa).

The conversion from the old unit of measure to the new one (SI) is the following :

$$1 \text{ Kp/cm}^2 = 0.981 \text{ bar}$$

$$1 \text{ bar} = 1.02 \text{ Kp/cm}^2$$

The conversion in the SI unit is also possible where the metric system is not yet used.

Conversion	:	1 bar	=	14.50 psi
		1 psi	=	0.07 bar = 7.000 Pa

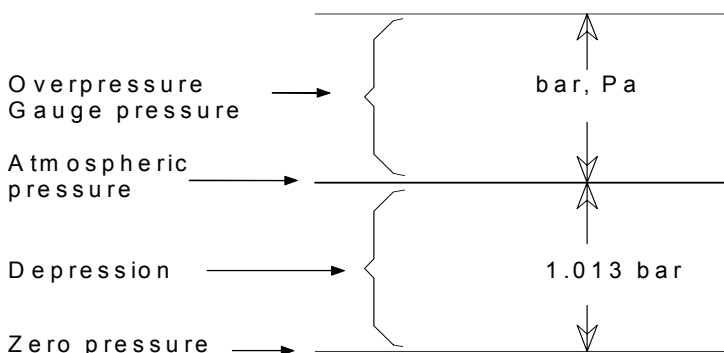

Pressure values, except specific references, are referred to the atmospheric pressure.

## 1.8 Flow calculation

Each solenoid valve has a flow coefficient (Kv).

It is possible, with this data, to calculate the flow. Given the loss of flowing pressure (pressure drop), the media type and the working pressure it's possible to calculate the flow rate.

This flow coefficient is determined by way of experimentation according to the standard VDE 2173 and it represents the quantity of water discharged from the solenoid valve with a pressure difference of 1 bar at a temperature between 5°C and 40°C.

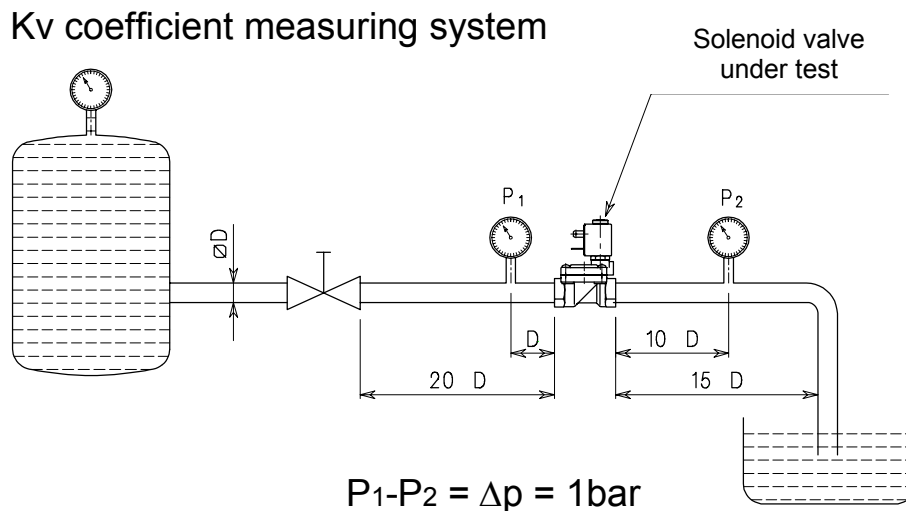

Kv	=	m <sup>3</sup> /h	Flow coefficient
Q	=	m <sup>3</sup> /h	Flow
Q <sub>n</sub>	=	m <sup>3</sup> <sub>n</sub> /h	Normal flow (20°C 760mm Hg)
P <sub>1</sub>	=	bar	Inlet pressure (Gauge pressure + 1)
P <sub>2</sub>	=	bar	Outlet pressure (Gauge pressure + 1)
Δp	=	bar	Pressure drop (differential pressure between inlet & outlet )
ρ	=	Kg/dm <sup>3</sup>	Relative density referred to water ( Water at 4°C = 1)



$\rho_n$	=	Kg/dm <sup>3</sup>	Normal relative density referred to air
G	=	Kg/h	Mass
t	=	°C	Inlet media temperature
$V_1$	=	m <sup>3</sup> /Kg	Inlet specific volume
$V_2$	=	m <sup>3</sup> /Kg	Outlet specific volume referred to "P2" pressure and "t" temperature

Liquids :  $Q = Kv \sqrt{\frac{\Delta p}{\rho}}$

Gas :  $\Delta p = \Delta p < \frac{P_1}{2} \quad Q_n = 514 \times Kv \sqrt{\frac{\Delta p \times P_2}{\rho_n \times (273 + t)}}$

$\Delta p = \Delta p > \frac{P_1}{2} \quad Q_n = 257 \times Kv \frac{P_1}{\sqrt{\rho_n (273 + t)}}$

Air :  $\Delta p = \Delta p < \frac{P_1}{2} \quad Q_n = 26 \times Kv \sqrt{\Delta p \times P_2}$

$\Delta p = \Delta p > \frac{P_1}{2} \quad Q_n = Kv \times P_1 \times 13$

Steam :  $\Delta p = \Delta p < \frac{P_1}{2} \quad G = 31.6 \times Kv \sqrt{\frac{\Delta p}{V_2}}$

$\Delta p = \Delta p > \frac{P_1}{2} \quad G = 31.6 \times Kv \sqrt{\frac{P_1}{V_1}}$



## 1.9 Technical tables

### 1.9.1 Pressure

bar	N/cm <sup>2</sup>	MPa	Psi	bar	N/cm <sup>2</sup>	MPa	Psi
0.1	1	0.01	1.45	14	140	1.4	203.00
0.2	2	0.02	2.90	15	150	1.5	217.50
0.3	3	0.03	4.35	16	160	1.6	232.00
0.4	4	0.04	5.80	17	170	1.7	246.50
0.5	5	0.05	7.25	18	180	1.8	261.00
0.6	6	0.06	8.70	19	190	1.9	275.50
0.7	7	0.07	10.15	20	200	2.0	390.00
0.8	8	0.08	11.60	21	210	2.1	304.50
0.9	9	0.09	13.05	22	220	2.2	316.00
1.0	10	0.10	14.50	23	230	2.3	333.50
1.5	15	0.15	21.75	24	240	2.4	348.00
2.0	20	0.20	29.00	25	250	2.5	362.50
2.5	25	0.25	36.25	26	260	2.6	377.00
3.0	30	0.30	43.50	27	270	2.7	391.50
3.5	35	0.35	50.75	28	280	2.8	406.00
4.0	40	0.40	58.00	29	290	2.9	420.50
4.5	45	0.45	65.25	30	300	3.0	435.00
5.0	50	0.50	72.50	35	350	3.5	507.50
5.5	55	0.55	79.75	40	400	4.0	580.00
6.0	60	0.60	87.00	45	450	4.5	652.50
6.5	65	0.65	94.25	50	500	5.0	725.00
7.0	70	0.70	101.50	55	550	5.5	797.50
7.5	75	0.75	108.75	60	600	6.0	870.00
8.0	80	0.80	116.00	65	650	6.5	942.50
8.5	85	0.85	123.25	70	700	7.0	1015.00
9.0	90	0.90	130.50	75	750	7.5	1087.50
9.5	95	0.95	137.75	80	800	8.0	1160.00
10.0	100	1.00	145.00	85	850	8.5	1232.50
11.0	110	1.10	159.50	90	900	9.0	1305.00
12.0	120	1.20	174.00	95	950	9.5	1377.50
13.0	130	1.30	188.50	100	1000	10.0	1450.00

### 1.9.2 Viscosity

Kinematic viscosity centistokes cSt (mm <sup>2</sup> /s)	°Engler °E	Saybolt Universal Ssu	Redwood Seconds n°1 SRW n°1
1	1	---	---
2	1.1	32.7	31
3	1.2	36	33.5
4	1.3	39	36
5	1.4	42.5	38.5
7	1.5	49	44
10	1.8	59	52
15	2.3	77.5	68
20	2.9	98	86
25	3.4	119	105
30	4	140	120
35	4.7	164	145
40	5.3	186	165
50	6.6	232	205
60	8	278	245
70	9.2	324	286
80	10.5	370	327
90	12	415	370
100	13	465	410

## 1.9.3 Temperatures

°C	K	°F	°C	K	°F	°C	K	°F	°C	K	°F
-50	223	-58.0	1	274	33.8	51	324	123.8	105	378	221.0
-49	224	-56.2	2	275	35.6	52	325	125.6	110	383	230.0
-48	225	-54.4	3	276	37.4	53	326	127.4	115	388	239.0
-47	226	-52.6	4	277	39.2	54	327	129.2	120	393	248.0
-46	227	-50.8	5	278	41.0	55	328	131.9	125	398	257.0
-45	228	-49.0	6	279	42.8	56	329	132.8	130	403	266.0
-44	229	-47.2	7	280	44.6	57	330	134.6	135	408	275.0
-43	230	-45.4	8	281	46.4	58	331	136.4	140	413	284.0
-42	231	-43.6	9	282	48.2	59	332	138.2	145	418	293.0
-41	232	-41.8	10	283	50.0	60	333	140.0	150	423	303.0
-40	233	-40.0	11	284	51.8	61	334	141.8	155	428	311.0
-39	234	-38.2	12	285	53.6	62	335	143.6	160	433	320.0
-38	235	-36.4	13	286	55.4	63	336	145.4	165	438	329.0
-37	236	-34.6	14	287	57.2	64	337	147.2	170	443	338.0
-36	237	-32.8	15	288	59.0	65	338	149.0	175	448	347.0
-35	238	-31.0	16	289	60.8	66	339	150.8	180	453	356.0
-34	239	-29.2	17	290	62.6	67	340	152.6	185	458	365.0
-33	240	-27.4	18	291	64.4	68	341	154.4	190	463	374.0
-32	241	-25.6	19	292	66.2	69	342	156.2	195	468	383.0
-31	242	-23.8	20	293	68.0	70	343	158.0	200	473	392.0
-30	243	-22.0	21	294	69.8	71	344	159.8	205	478	401.0
-29	244	-20.2	22	295	71.6	72	345	161.6	210	483	410.0
-28	245	-18.4	23	296	73.4	73	346	163.4	215	488	419.0
-27	246	-16.6	24	297	75.2	74	347	165.2	220	493	428.0
-26	247	-14.8	25	298	77.0	75	348	167.0	225	498	437.0
-25	248	-13.0	26	299	78.8	76	349	168.8	230	503	446.0
-24	249	-11.2	27	300	80.6	77	350	170.6	235	508	455.0
-23	250	-9.4	28	301	82.4	78	351	172.4	240	513	464.0
-22	251	-7.6	29	302	84.2	79	352	174.2	245	518	473.0
-21	252	-5.8	30	303	86.0	80	353	176.0	250	523	482.0
-20	253	-4.0	31	304	87.8	81	354	177.8	255	528	491.0
-19	254	-2.2	32	305	89.6	82	355	179.6	260	533	500.0
-18	255	-0.4	33	306	91.4	83	356	181.4	265	538	509.0
-17	256	1.4	34	307	93.2	84	357	183.2	270	543	518.0
-16	257	3.2	35	308	95.0	85	358	185.0	275	548	527.0
-15	258	5.0	36	309	96.8	86	359	186.8	280	553	536.0
-14	259	6.8	37	310	98.6	87	360	188.6	285	558	545.0
-13	260	8.6	38	311	100.4	88	361	190.4	290	563	554.0
-12	261	10.4	39	312	102.2	89	362	192.2	295	568	563.0
-11	262	12.2	40	313	104.0	90	363	194.0	300	573	572.0
-10	263	14.0	41	314	105.8	91	364	195.8	310	583	590.0
-9	264	15.8	42	315	107.6	92	365	197.6	320	593	608.0
-8	265	17.6	43	316	109.4	93	366	199.4	330	603	626.0
-7	266	19.4	44	317	111.2	94	367	201.2	340	613	644.0
-6	267	21.2	45	318	113.0	95	368	203.0	350	623	662.0
-5	268	23.0	46	319	114.8	96	369	204.8	360	633	680.0
-4	269	24.8	47	320	116.6	97	370	206.6	370	643	698.0
-3	270	26.6	48	321	118.4	98	371	208.4	380	653	716.0
-2	271	28.4	49	322	120.2	99	372	210.2	390	663	734.0
-1	272	30.2	50	323	122.0	100	373	212.0	400	673	752.0
0	273	32.0									

## 1.9.4 Steam

Relative pressure (bar)	Absolute pressure (bar)	Temperature (°C)	Steam specific volume (m³/kg)
---	<b>0.050</b>	<b>32.88</b>	<b>28.192</b>
---	<b>0.500</b>	<b>81.33</b>	<b>3.240</b>
<b>0.00</b>	<b>1.013</b>	<b>100.00</b>	<b>1.673</b>
<b>0.10</b>	<b>1.113</b>	<b>102.66</b>	<b>1.533</b>
<b>0.20</b>	<b>1.213</b>	<b>105.10</b>	<b>1.414</b>
<b>0.35</b>	<b>1.363</b>	<b>108.50</b>	<b>1.268</b>
<b>0.50</b>	<b>1.513</b>	<b>111.61</b>	<b>1.149</b>
<b>0.70</b>	<b>1.713</b>	<b>115.40</b>	<b>1.024</b>
<b>1.00</b>	<b>2.013</b>	<b>120.42</b>	<b>0.881</b>
<b>1.50</b>	<b>2.513</b>	<b>127.62</b>	<b>0.714</b>
<b>2.00</b>	<b>3.013</b>	<b>133.69</b>	<b>0.603</b>
<b>2.50</b>	<b>3.513</b>	<b>139.02</b>	<b>0.522</b>
<b>3.00</b>	<b>4.013</b>	<b>143.75</b>	<b>0.461</b>
<b>3.50</b>	<b>4.513</b>	<b>148.02</b>	<b>0.413</b>
<b>4.00</b>	<b>5.013</b>	<b>151.96</b>	<b>0.374</b>
<b>4.50</b>	<b>5.513</b>	<b>155.55</b>	<b>0.342</b>
<b>5.00</b>	<b>6.013</b>	<b>158.92</b>	<b>0.315</b>
<b>6.00</b>	<b>7.013</b>	<b>165.04</b>	<b>0.272</b>
<b>7.00</b>	<b>8.013</b>	<b>170.50</b>	<b>0.240</b>
<b>8.00</b>	<b>9.013</b>	<b>175.43</b>	<b>0.215</b>
<b>9.00</b>	<b>10.013</b>	<b>179.97</b>	<b>0.194</b>
<b>10.00</b>	<b>11.013</b>	<b>184.13</b>	<b>0.177</b>

## 1.9.5 Specific gravity

Liquid substances			Gases and vapors at 20°C and 1atm *		
Liquid	Temp. (°C)	Specific gravity (Kg/dm <sup>3</sup> )	Gases and vapors	Specific gravity	
				Relative density to air	(Kg/m <sup>3</sup> )
Acetone	25	0,787	Acetylene (ethyne)	0,90	1,085
Acetylene, liquid	70°F	0,38	Air	1,00	1,205
Alcohol, ethyl (ethanol)	25	0,787	Alcohol vapor	1,60	1,929
Alcohol, methyl (methanol)	25	0,791	Ammonia	0,59	0,711
Alcohol, propyl	25	0,802	Argon	1,38	1,663
Ammonia (aqua)	25	0,826	Benzene	2,70	3,249
Aniline	25	1,022	Butane	2,01	2,417
Benzene	25	0,876	Isobutene	1,94	2,338
Benzil	25	1,084	Carbon dioxide	1,52	1,830
Bromine	25	3,12	Carbon monoxide	0,97	1,165
Butane, liquid	25	0,601	Chlorine	2,49	2,996
Caustic soda 9% - NaOH	15	1,10	Cyclobutane	1,94	2,335
Caustic soda 18% - NaOH	15	1,20	Cyclopentane	2,42	2,919
Caustic soda 27% - NaOH	15	1,30	Cyclopropane	1,45	1,748
Caustic soda 47% - NaOH	15	1,50	Deuterium	0,07	0,084
Chloroform	25	1,469	Ethane	1,04	1,251
Ethane	-89	0,572	Ether vapor	2,59	3,116
Ether	25	0,716	Ethyl Chloride	2,23	2,687
Ethylene glycol	25	1,1	Ethylene (Ethene)	0,97	1,167
Formaldehyde	45	0,815	Fluorine	1,31	1,579
Freon R-11	25	1,48	Helium	0,14	0,166
Freon R-12	25	1,315	Heptanes	3,46	4,168
Freon R-22	25	1,197	Hexane	2,97	3,582
Fuel oil	60°F	0,893	Hydrogen	0,07	0,084
Gasoline, Vehicle	60°F	0,739	Hydrogen chloride	1,27	1,528
Hydrochloric acid 10%	15	1,05	Hydrogen sulfide	1,18	1,417
Hydrochloric acid 20%	15	1,10	Hydrofluoric acid	2,37	2,856
Hydrochloric acid 30%	15	1,15	Hydrochloric acid	1,26	1,520
Hydrochloric acid 40%	15	1,20	Illuminating gas	0,40	0,482
Kerosene	60°F	0,82	Isobutane	2,01	2,422
Mercury	25	13,633	Isopentane	2,48	2,988
Milk	15	1,035	Mercury vapor	6,94	8,363
Naphtha	15	0,667	Methane	0,55	0,667
Nitric acid 17%	15	1,10	Natural Gas (typical)	0,7 - 0,5	0,844 - 0,723
Nitric acid 25%	15	1,15	Neon	0,70	0,840
Nitric acid 47%	15	1,30	Nitrogen	0,97	1,165
Nitric acid 94%	15	1,50	Nitrous oxide	1,53	1,844
Octane	25	0,701	Octane	3,94	4,753
Olive Oil	15	0,703	Oxygen	1,10	1,331
Oxygen	-183	1,14	Ozone	1,66	2,000
Potassium Hydroxide 21%	15	1,2	Pentane	2,49	2,997
Potassium Hydroxide 49%	15	1,5	Propane	1,52	1,834
Propane	25	0,495	Propene (Propylene)	1,45	1,750
Sulphuric acid 27%	15	1,20	R-12	4,17	5,030
Sulphuric acid 50%	15	1,40	R-134A	3,52	4,244
Sulphuric acid 87%	15	1,80	Sulfur Dioxide	2,26	2,728
Sulphuric acid, pure	15	1,89	Water vapor	0,62	0,749
Turpentine	25	0,871	Xenon	4,53	5,459
Water, pure	4	1			
Water, sea	77°F	1,025			

\*) NTP - Normal Temperature and Pressure - is defined as air at 20°C and 1 atm

Specific gravity is the ratio between the density (mass per unit volume) of the actual gas and the density of air, specific gravity has no dimension. The density of air at NTP is 1.205 kg/m<sup>3</sup>.

## 1.10 Response time

The Response time ( $R_t$ ) of a solenoid valve is the period passing between the energisation (or de-energisation) of the coil and the moment when the outlet pressure reaches the 50% of its peak.  
 Example of a circuit test :

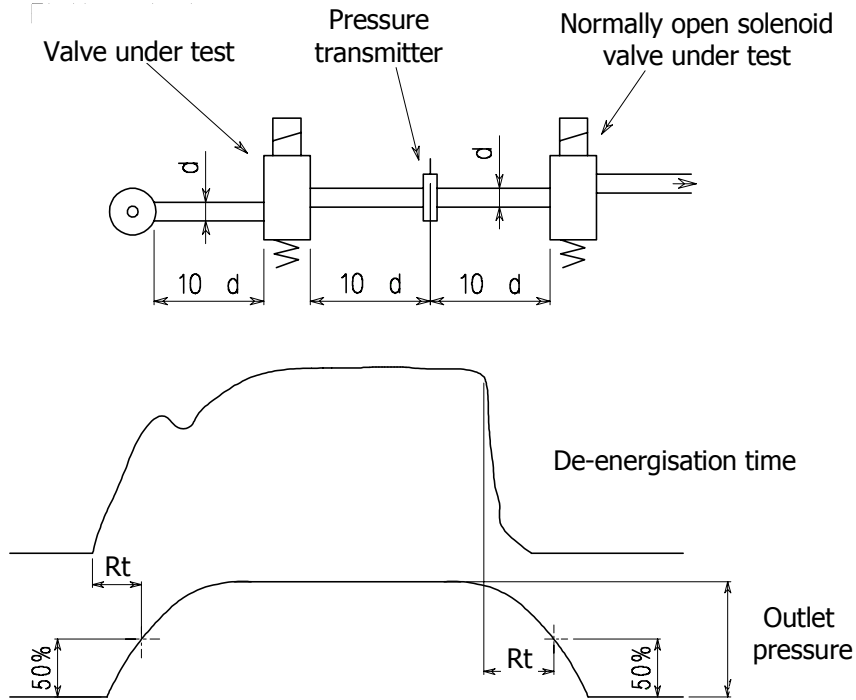

The response time depends from the type of valve, the nature of the medium, the pressure and the current (AC or DC), if these value are measured at the moment of electrical connection or disconnection.

SERIES	Tr (ms)		NOTES
	Air P=6 bar Opening	Closing	
2 & 3 ways direct acting NC	8	25	With liquids +50% ÷150% depending on the viscosity
2 & 3 ways direct acting NO	25	8	
Servoassisted NC G3/8 & G1/2 G3/4 & G1	30	50	
	50	70	
Servoassisted NO G3/8 & G1/2 G3/4 & G1	50	30	
	70	50	
Servoassisted G1"1/4 - G1"1/2 - G2" G2"1/2 - G3"	Adjustable time		



## **1.11 P.E.D. Directive (97/23/EC)**

### **P.E.D. DECLARATION OF CONFORMITY**

**ACL S.r.l.  
Via Giovanni Falcone, 6  
20873 Cavenago di Brianza (MI)**

Declares that the solenoid valves listed in the present catalogue are in conformity with the following EU directive

**97/23/EC (Pressure Equipment Directive)**

We also declare that they are not allowed to carry the CE mark in conformity to the article 3, paragraph 3.

**Remark:**

In case that on our goods you will find the CE sticker, means that the product meets the EC 89/336, EC 92/31, EC 93/68, EC 72/23.

Limitedly to the rules apply by EN 55014, EN 61000-3-2, EN 61000-3-3, EN 60335-1 (CEI 61-150 volume N 2616E).

## 1.12 Operating instructions and installation

### 1. PRECAUTIONS DURING THE HYDRAULIC CONNECTION

Check that the valve series meets the application. Don't exceed the specification shown on the valve label.

Check that the fluid is in the same direction as the arrow stamped on the valve body and that the pipes are compatible with the flow rate of the valve.

Check that the pipes are clean and, if possible, fit a filter before the valve.

When connecting the valve, make sure that no foreign matter and sealing materials such as tape and jointing paste get inside the valve, as this could obstruct the internal pilot holes. (pilot operated valves)

When making connections using a wrench, apply force only the body of the valve. Avoid the coil area.

The solenoid valve can work in any position but to avoid the eventual precipitation of impurities inside the guide tube it's recommended that the coil is positioned above a horizontal pipe run.

When connecting with flexible tubes, it's recommended to use the provided fixing holes. (types with 1/8" and 1/4" threads)

### 2. PRECAUTIONS DURING THE ELECTRICAL CONNECTION

Check if the electrical data on the coil are compatible with the electrical supply.

The direct current valves don't require a fixed polarity with the exception of bi-stable valves.

To help heat dissipation of the coil, put the valve in a ventilated environment away from any other heat source.

It's possible that the coil working temperature could, in conjunction with ambient and fluid temperatures, cause scorching.

It's recommended an appropriate protection of the coil from water and humidity.

The coil fixing nut should not be over tightened. Don't exceed a torque more than 1.5Nm

### 3. MAINTENANCE

Coils can be changed without removing the valve from the system.

Spare parts are available for all wearing valve components.

When replacing the guide tube do not exceed the following tightening torque :

Normally Open valves	Normally Closed valves
16mm wrench=10Nm	11mm wrench=5Nm
22mm wrench=20Nm	16mm wrench=15Nm
	22mm wrench=50Nm

Before removing the valve, check that the power supply has been switched off and that no pressure is present in the pipeline.

If the valve needs cleaning, pay special attention to the seat area to avoid any damage.

The plunger must move freely inside the guide tube. If this isn't achievable due to incrustations, scale deposits or worn surfaces, then replacement parts must be fitted.

Seals must be replaced if swollen or damaged with incisions etc.

The diaphragm pilot holes must not be blocked to guarantee the correct operation of servo-assisted valves. Check that both holes are clear. Check also that the diaphragm has not hardened, swollen or it shows wear in the seat/seal area. Replace if necessary

### 4. GENERAL PRECAUTIONS

When the solenoid valve is used on machines or equipment with high mechanical stress (for example, vibrating stress), contact the manufacturer or verify life and functionality testes with appropriate tests.

## 1.13 Model identification

Solenoid valves are identified as follow :

### 1.13.1 DIRECT ACTING

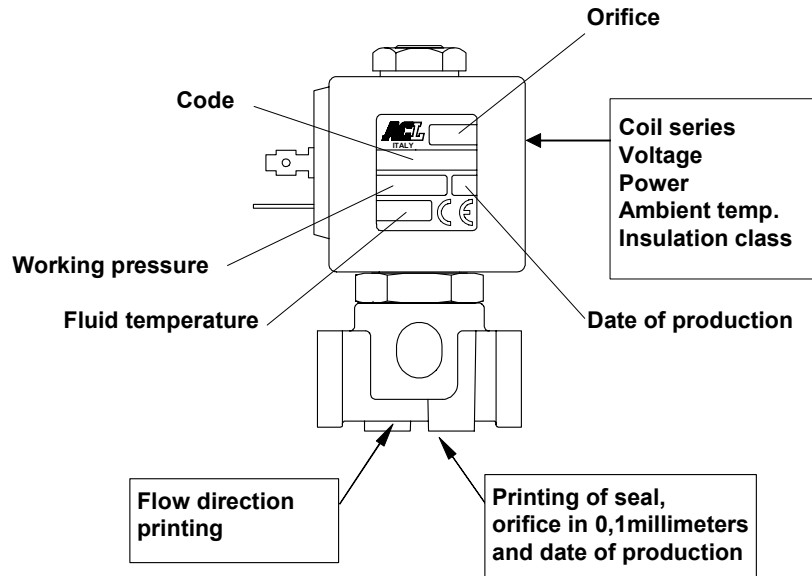

### 1.13.2 SERVO-ASSISTED

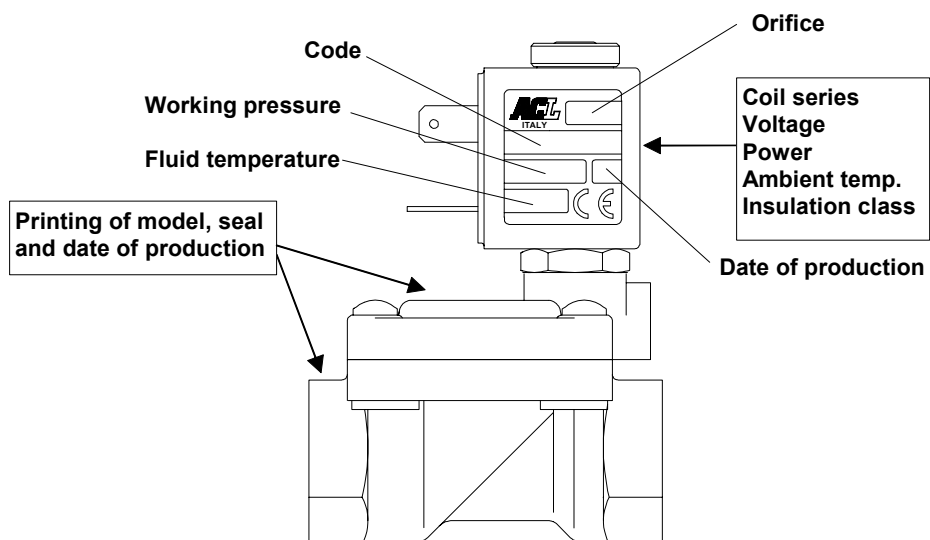



**DESCRIPTION**

Solenoid valve 2 way normally closed  
direct acting poppet type

**CONSTRUCTION**

Body	Brass
Armature tube	Brass
Plunger and core	Stainless steel
Springs	Stainless steel
Seal material	NBR
	FPM
	EPDM



**2**

**FEATURES**

Maximum allowable pressure 50 bar \*  
Maximum fluid viscosity 25cSt (mm<sup>2</sup>/s)  
Ambient temperature : with class F coil -10°C +55°C  
with class H coil -10°C +80°C  
Universal mounting position

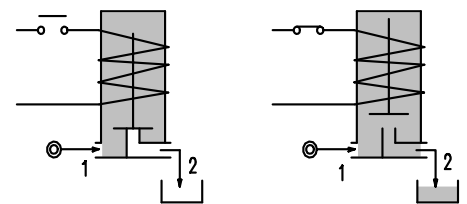
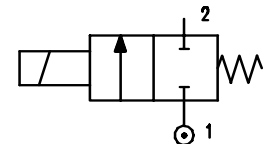

**OPTIONS :** Armature tube in stainless steel  
Electroless nickel plating  
Explosion proof coil according to ATEX - EExmII Series7  
Manual override  
Version for use with oxygen

CODE ① ②	Connection G ISO 228	Orifice mm	KV m <sup>3</sup> /h	Differential pressure bar			Nominal power			Coil		Seal ①	Temp. range °C
				Min	Max		AC Inrush	VA Holding	DC Watt	Series	Width		
					AC	DC							
E105A.....12///.....	1/8"	1.2	0.04	0	25	25	12	8	6.5	3	22	NBR=B EPDM=E FPM=V	-10 +90  +<140  -10 +130
E105A.....15///.....		1.5	0.06	0	16	16							
E105A.....20///.....		2	0.09	0	12	10							
E105A.....25///.....		2.5	0.14	0	8	5.5							
E105A.....31///.....		3.1	0.19	0	5	2							
E105A.....40///.....		4	0.35	0	4	1.5							
E105A.....20///.....		2	0.09	0	25	15	15	11	5	4	30		
E105A.....25///.....		2.5	0.14	0	16	8							
E105A.....31///.....		3.1	0.19	0	8	4							
E105A.....40///.....	4	0.35	0	5	2.5								

- ① Seal
- ② Coil

Example: E105AB20///30B NBR seal  
Coil 24V 50/60Hz

\* REMARK: The maximum allowable pressure PS for steam is 2,5bar (gauge pressure)

COILS	Alternating Current ~50/60Hz Volt							Direct Current Volt			Electrical connection	Connectors
	12	24	48	110	220 230	240	380	12	24	48		
Series 3 Width 22 Code ②	30A	30B	30C	30D	30E	30F	30G	300	301	302	DIN 46244	PG9 code 10348000
Series 4 Width 30 Code ②	40A	40B	40C	40D	40E	40F	40G	400	401	402	DIN 43650A	PG9 code 10349000

**DESCRIPTION**  
 Class F insulation  
 Voltage tolerance  
 AC +15% -10%  
 DC ± 10%  
 Protection class  
 IP65 with connector fitted  
 IP00 without connector  
 Continuous service ED100%

**OPTIONS**  
 Class H insulation  
 Cable attached  
 Special coil voltage  
 Special coil powers

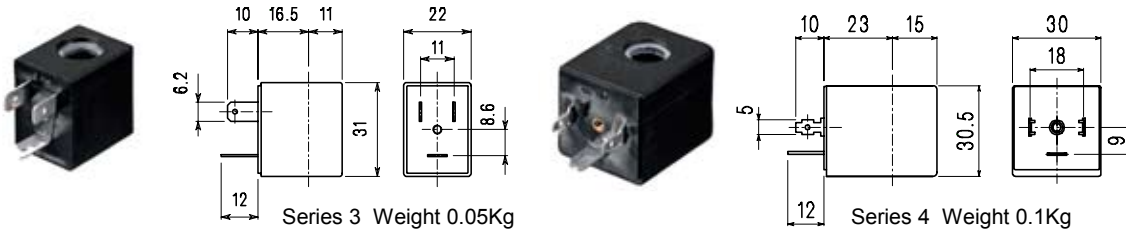

### SPARE PARTS LIST

1. Coil fixing nut
2. Coil
3. Plunger
4. Armature tube with core

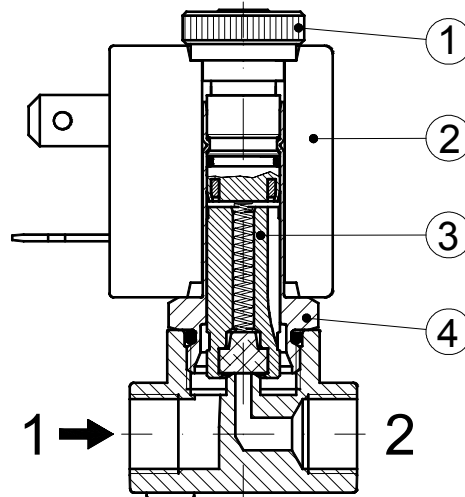

### MANUAL OVERRIDE

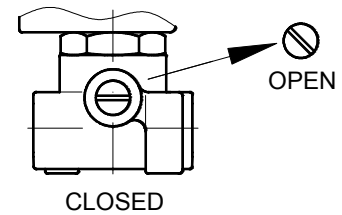

### OVERALL DIMENSION

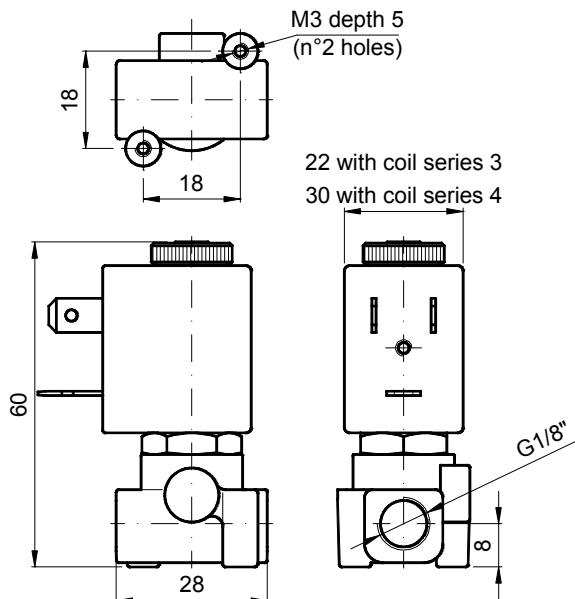

Weight with coil series 3 = 0.13 Kg  
 Weight with coil series 4 = 0.18 Kg

### DESCRIPTION

Solenoid valve 2 way normally closed  
direct acting poppet type

### CONSTRUCTION

Body	Brass
Armature tube	Brass
Plunger and core	Stainless steel
Springs	Stainless steel
Seal material	FPM



2

### FEATURES

Maximum allowable pressure 50 bar \*  
 Maximum fluid viscosity 25cSt (mm<sup>2</sup>/s)  
 Ambient temperature : with class F coil -10°C +55°C  
 with class H coil -10°C +80°C  
 Universal mounting position

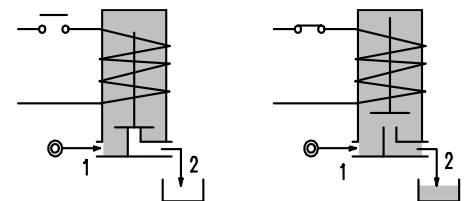
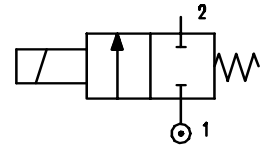

CODE ②	Connection G ISO 228	Orifice mm	KV m <sup>3</sup> /h	Differential pressure bar			Nominal power			Coil		Seal	Temp. range °C
				Min	Max		AC Inrush	VA Holding	DC Watt	Series	Width		
					AC	DC							
W105AV15///.....	1/8"	1.5	0.06	0	14	3	12	8	6.5	3	22	FPM=V	-10 +130

② Coil

\* REMARK: The maximum allowable pressure PS for steam is 2,5bar (gauge pressure)

COILS	Alternating Current ~50/60Hz Volt							Direct Current Volt			Electrical connection	Connectors
	12	24	48	110	220 230	240	380	12	24	48		
Series 3 Width 22 Code ②	30A	30B	30C	30D	30E	30F	30G	300	301	302	DIN 46244	PG9 code 10348000

**DESCRIPTION**  
 Class F insulation  
 Voltage tolerance  
 AC +15% -10%  
 DC ± 10%  
 Protection class  
 IP65 with connector mounted  
 IP00 without connector  
 Continuous service ED100%

**OPTIONS**  
 Class H insulation  
 Cable attached  
 Special coil voltage  
 Special coil powers

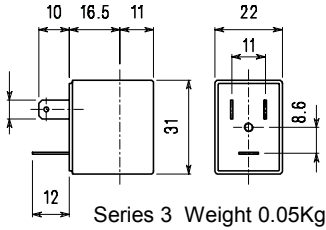

### SPARE PARTS LIST

1. Coil fixing nut
2. Coil
3. Valve

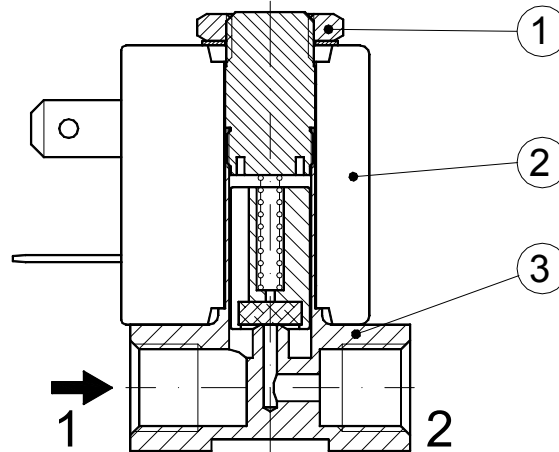

### OVERALL DIMENSION

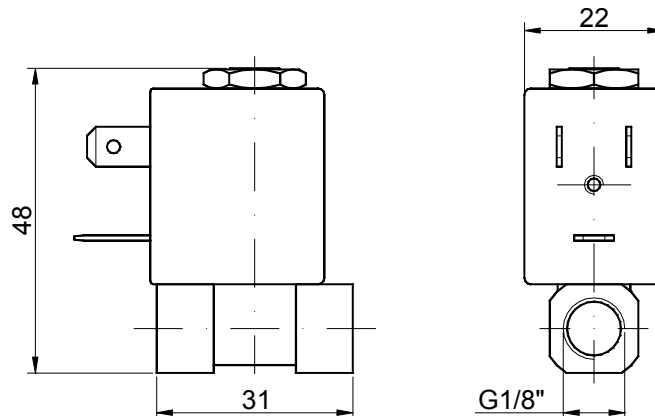

Weight = 0.09 Kg

## DESCRIPTION

Solenoid valve 2 way normally closed  
direct acting poppet type

## CONSTRUCTION

Body	Brass
Armature tube	Stainless steel
Plunger and core	Stainless steel
Springs	Stainless steel
Seal material	NBR
	FPM
	EPDM
	PTFE



2

## FEATURES

Maximum allowable pressure 80 bar \*  
Maximum fluid viscosity 25cSt (mm<sup>2</sup>/s)  
Ambient temperature : with class F coil -10°C +55°C  
with class H coil -10°C +80°C  
Universal mounting position

**OPTIONS :** Manual override  
Electroless nickel plating  
Stainless steel seat insert  
Version for use with oxygen

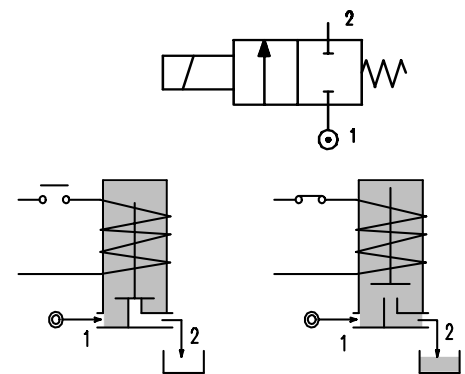

CODE ① ②	Connection G ISO 228	Orifice mm	KV m³/h	Differential pressure bar			Nominal power			Coil		Seal ①	Temp. Range °C
				Min	Max		AC Inrush	VA Holding	DC Watt	Series	Width		
					AC	DC							
E106A.....15///.....	1/8"	1.5	0.07	0	30	26	20	15	10	2	30	NBR=B	-10 +90
E106A.....20///.....		2	0.1	0	22	20							
E106A.....25///.....		2.5	0.15	0	16	14							
E106A.....35///.....		3.5	0.32	0	10	8							
E106B.....15///.....	1/4"	1.5	0.07	0	30	26							
E106B.....20///.....		2	0.1	0	22	20							
E106B.....25///.....		2.5	0.15	0	16	14							
E106B.....35///.....		3.5	0.32	0	10	8							
E106B.....45///.....		4.5	0.41	0	6.5	3.5							
E106B.....52///.....	5.2	0.47	0	4	1.8								
E106B.....64///.....	6.4	0.64	0	3	1								
E106A.....15///.....	1/8"	1.5	0.07	0	80	80							
E106A.....20///.....		2	0.1	0	50	40							
E106A.....25///.....		2.5	0.15	0	35	33							
E106A.....35///.....		3.5	0.32	0	20	19							
E106B.....15///.....	1/4"	1.5	0.07	0	80	80							
E106B.....20///.....		2	0.1	0	50	40							
E106B.....25///.....		2.5	0.15	0	35	33							
E106B.....35///.....		3.5	0.32	0	20	19							
E106B.....45///.....		4.5	0.41	0	14	13							
E106B.....52///.....		5.2	0.47	0	10	9							
E106B.....64///.....	6.4	0.64	0	5	4.5								

① Seal Example: E106BB52///20E NBR seal  
② Coil Coil 220V 50/60Hz

③ Maximum allowable leakage < 0.2nL/h

\* REMARK: The maximum allowable pressure PS for steam is 6 bar (gauge pressure) with PTFE seals and 2,5bar with EPDM seals

COILS	Alternating Current ~50/60Hz Volt							Direct Current Volt			Electrical connection	Connectors
	12	24	48	110	220 230	240	380	12	24	48		
Series 2 Width 30 Code ②	20A	20B	20C	20D	20E	20F	20G	200	201	202	DIN 43650A	PG9 code 10349000
Series 5 Width 36 Code ②	52A	52B	52C	52D	52E	52F	52G	520	521	522	DIN 43650A	PG11 code 10349001

**DESCRIPTION**  
 Insulation class  
 Series 2=F Series 5=H  
 Voltage tolerance  
 AC +15% -10%  
 DC ± 10%  
 Protection class  
 IP65 with connector fitted  
 IP00 without connector  
 Continuous service ED100%

**OPTIONS**  
 Class H insulation (series 2)  
 Cable attached  
 Special coil voltages  
 Special coil powers

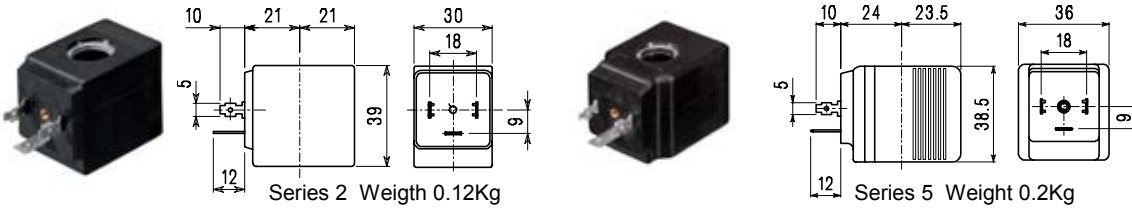

### SPARE PARTS LIST

1. Coil fixing nut
2. Coil
3. Plunger
4. Armature tube with core

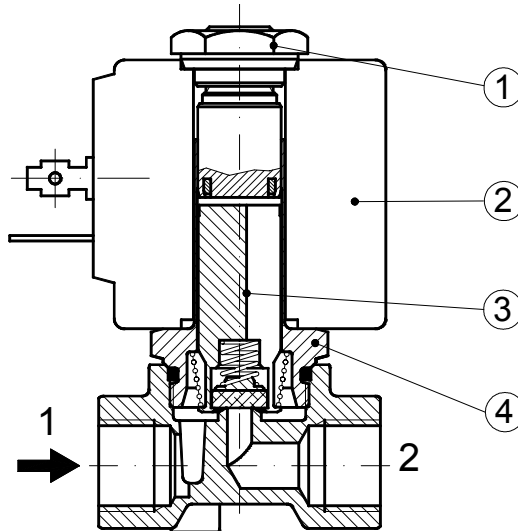

### MANUAL OVERRIDE

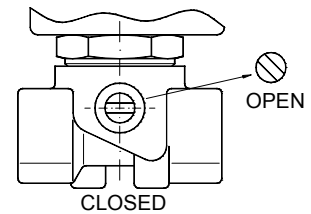

### OVERALL DIMENSION

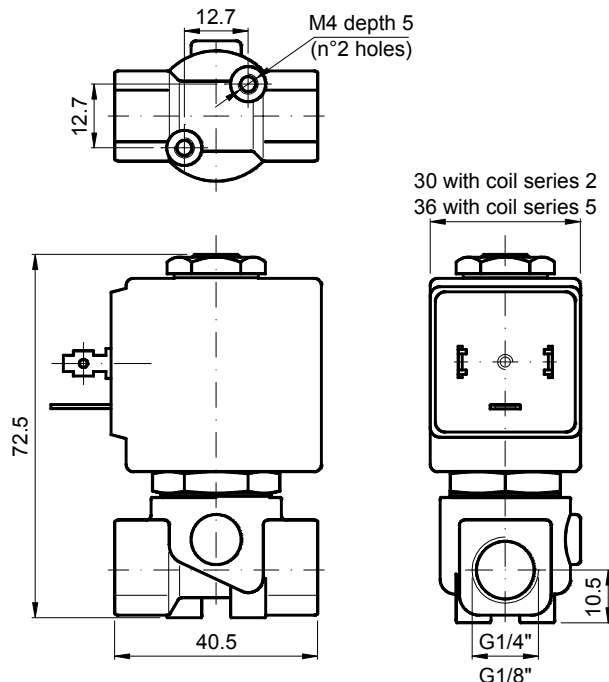

Weight with coil series 2 = 0.30 Kg  
 Weight with coil series 5 = 0.38 Kg

## DESCRIPTION

Solenoid valve 2 way normally closed  
direct acting poppet type

## CONSTRUCTION

Body	Brass
Armature tube	Stainless steel
Plunger and core	Stainless steel
Springs	Stainless steel
Seal material	NBR
	FPM
	EPDM
	PTFE



2

## FEATURES

Maximum allowable pressure 80 bar \*  
Maximum fluid viscosity 25cSt (mm<sup>2</sup>/s)  
Ambient temperature : with class F coil -10°C +55°C  
with class H coil -10°C +80°C  
Universal mounting position

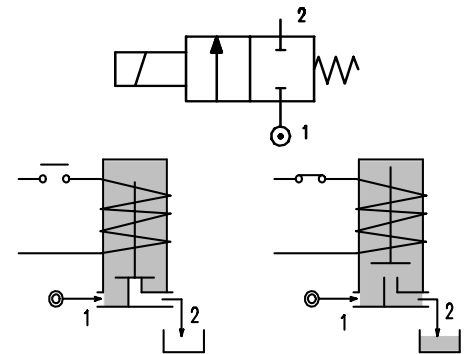

**OPTIONS :** Electroless nickel plating  
For use with oxygen

CODE ① ②	Connection G ISO 228	Orifice mm	KV m <sup>3</sup> /h	Differential pressure bar			Nominal power			Coil		Seal ①	Temp. range °C
				Min	Max		AC Inrush	VA Holding	DC Watt	Series	Width		
					AC	DC							
E106C.....30///.....	3/8"	3	0.25	0	15	10	20	15	10	2	30	NBR=B	-10 +90
E106C.....35///.....		3.5	0.32	0	10	8							
E106C.....40///.....		4	0.36	0	8	5							
E106C.....45///.....		4.5	0.41	0	6.5	3.5							
E106C.....52///.....		5.2	0.47	0	4	1.8							
E106C.....64///.....		6.4	0.64	0	3	1							
E106D.....30///.....	1/2"	3	0.25	0	15	10	20	15	10	2	30	EPDM=E	<+140
E106D.....35///.....		3.5	0.32	0	10	8							
E106D.....40///.....		4	0.36	0	8	5							
E106D.....45///.....		4.5	0.41	0	6.5	3.5							
E106D.....52///.....		5.2	0.47	0	4	1.8							
E106D.....64///.....		6.4	0.64	0	3	1							
E106C.....30///.....	3/8"	3	0.25	0	25	24	40	30	27	5	36	FPM=V	-10 +130
E106C.....35///.....		3.5	0.32	0	20	19							
E106C.....40///.....		4	0.36	0	16	15							
E106C.....45///.....		4.5	0.41	0	14	13							
E106C.....52///.....		5.2	0.47	0	10	9							
E106C.....64///.....		6.4	0.64	0	5	4.5							
E106D.....30///.....	1/2"	3	0.25	0	25	24	40	30	27	5	36	PTFE=W ③	-10 +160
E106D.....35///.....		3.5	0.32	0	20	19							
E106D.....40///.....		4	0.36	0	16	15							
E106D.....45///.....		4.5	0.41	0	14	13							
E106D.....52///.....		5.2	0.47	0	10	9							
E106D.....64///.....		6.4	0.64	0	5	4.5							

- ① Seal Example: E106CE35///521 EPDM seal  
② Coil Coil 24V DC  
③ Maximum allowable leakage < 0.2 nL/h

\* REMARK: The maximum allowable pressure PS for steam is 6 bar (gauge pressure) with PTFE seals and 2,5bar with EPDM seals

COILS	Alternating Current ~50/60Hz Volt							Direct Current Volt			Electrical connection	Connectors
	12	24	48	110	220 230	240	380	12	24	48		
Series 2 Width 30 Code ②	20A	20B	20C	20D	20E	20F	20G	200	201	202	DIN 43650A	PG9 code 10349000
Series 5 Width 36 Code ②	52A	52B	52C	52D	52E	52F	52G	521	521	522	DIN 43650A	PG11 code 10349001

**DESCRIPTION**  
 Insulation class  
 Series 2=F Series 5=H  
 Voltage tolerance  
 AC +15% -10%  
 DC ± 10%  
 Protection class  
 IP65 with connector fitted  
 IP00 without connector  
 Continuous service ED100%

**OPTIONS**  
 Class H insulation (series 2)  
 Cable attached  
 Special coil voltages  
 Special coil powers

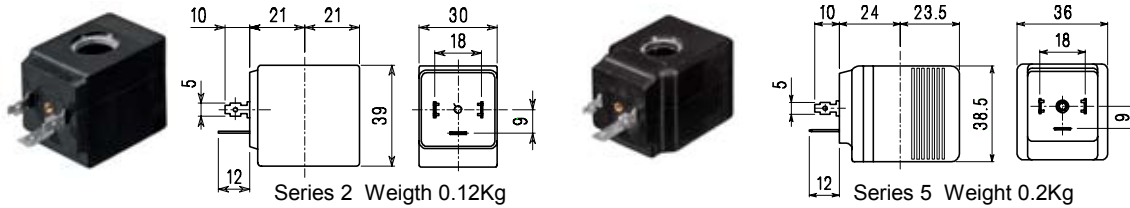

### SPARE PARTS LIST

1. Coil fixing nut
2. Coil
3. Plunger
4. Armature tube with core

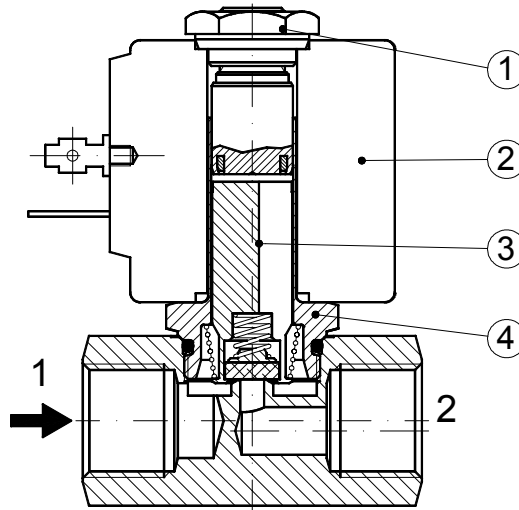

### OVERALL DIMENSION

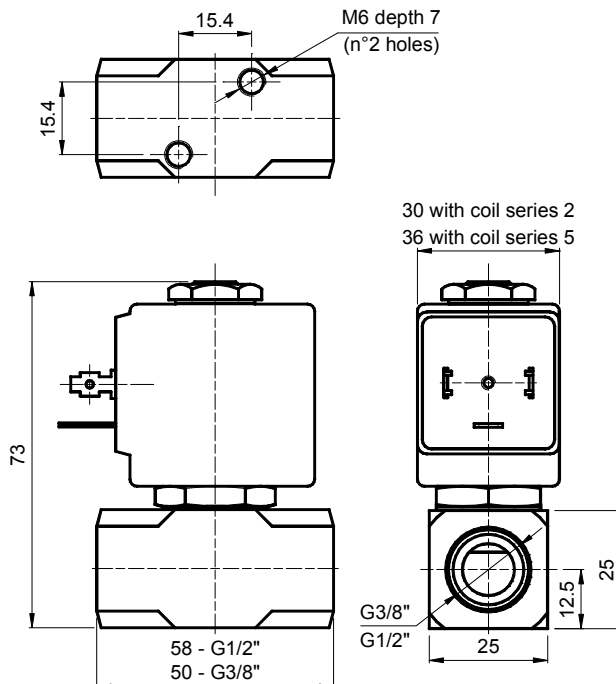

Weight with coil series 2 = 0.36 Kg  
 Weight with coil series 5 = 0.44 Kg



**DESCRIPTION**

Solenoid valve 2 way normally closed direct acting poppet type.  
 With explosion proof coil certified:  
 CESI 03 ATEX 344 ExII2G/D Eex "d" IIC T6

**VALVE CONSTRUCTION**

Body Brass  
 Seal material FPM

**EXPLOSION PROOF CONSTRUCTION**

Housing Red colour alloy  
 Electrical connection 1/2" NPT



**2**

**FEATURES**

Maximum allowable pressure 80 bar  
 Maximum fluid viscosity 25cSt (mm<sup>2</sup>/s)  
 Ambient temperature : -10°C +40°C  
 Mounting position with vertical coil above

**OPTIONS :** Manual override  
 Electroless nickel plating  
 Stainless steel seat

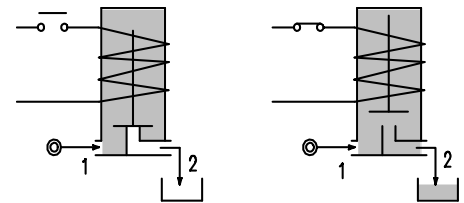
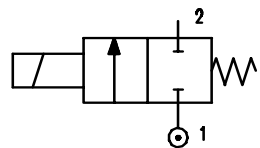

**NOTE:** The solenoid valve is suitable only with media that are **NOT** potentially explosive.

CODE ②	Connection G ISO 228	Orifice mm	KV m <sup>3</sup> /h	Differential pressure bar			Nominal power		Coil Series	Seal	Temperature range °C
				Min	Max		AC Holding	DC Watt			
					AC	DC					
A106AV15///.....	1/8"	1.5	0.07	0	30	26	12 VA	8 W	A6	FPM=V	-10 +130
A106AV20///.....		2	0.1	0	22	20					
A106AV25///.....		2.5	0.15	0	16	14					
A106AV35///.....		3.5	0.32	0	10	8					
A106BV15///.....	1/4"	1.5	0.07	0	30	26					
A106BV20///.....		2	0.1	0	22	20					
A106BV25///.....		2.5	0.15	0	16	14					
A106BV35///.....		3.5	0.32	0	10	8					
A106BV45///.....		4.5	0.41	0	6.5	3.5					
A106BV52///.....		5.2	0.47	0	4	1.8					
A106BV64///.....		6.4	0.64	0	3	1					

② Coil

COILS	Alternating Current ~50/60Hz Volt				Direct Current Volt			Electrical connection
	24	48	110	220 230	12	24	48	
Series <b>A6</b> Code ②	A6B	A6C	A6D	A6E	A60	A61	A62	1/2" NPT

**DESCRIPTION**  
 Voltage tolerance  
 AC +15% -10%  
 DC ± 10%  
 Protection class IP66

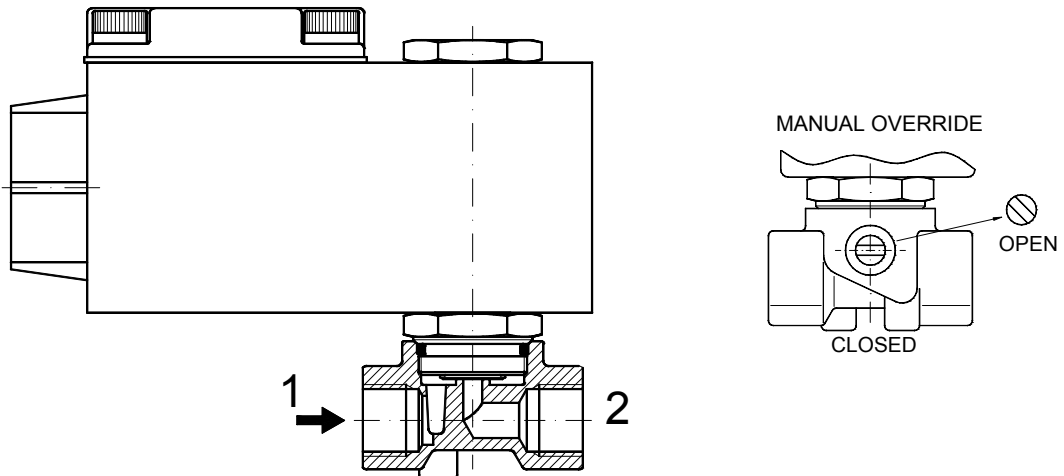

### OVERALL DIMENSION

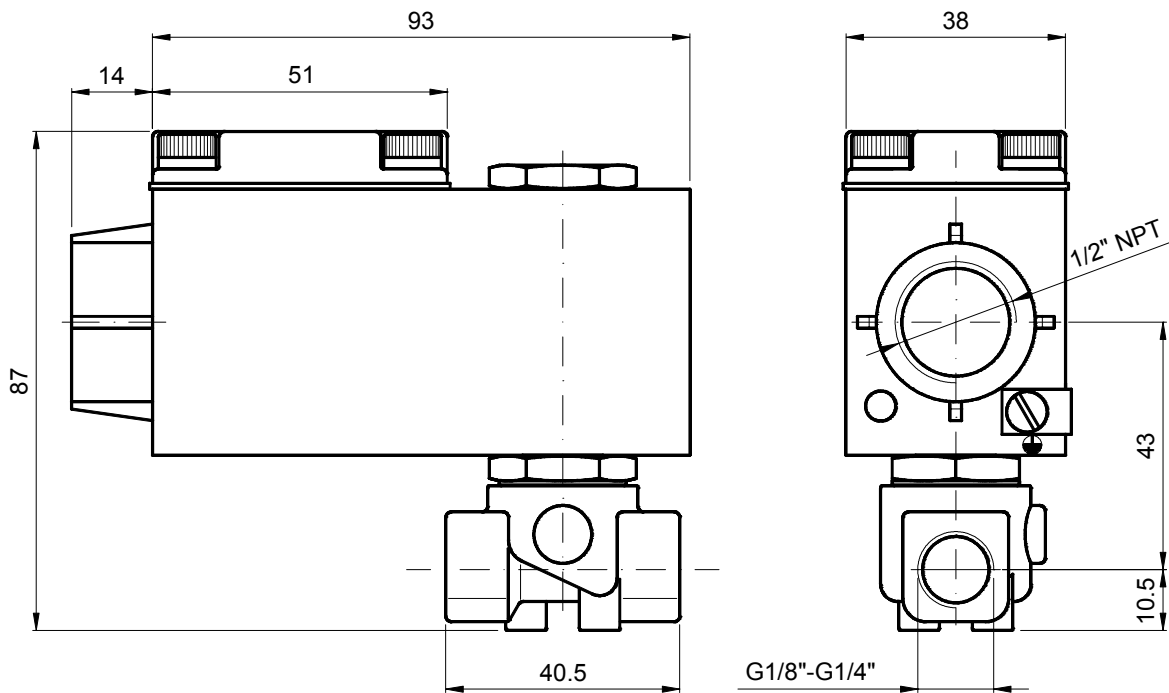

Weight = 0.60 Kg

**DESCRIPTION**

Solenoid valve 2 way normally closed direct acting poppet type.  
 With explosion proof coil certified:  
 CESI 03 ATEX 344 ExII2G/D Eex "d" IIC T6

**VALVE CONSTRUCTION**

Body Brass  
 Seal material FPM

**EXPLOSION PROOF CONSTRUCTION**

Housing Red colour alloy  
 Electrical connection 1/2" NPT



**2**

**FEATURES**

Maximum allowable pressure 80 bar  
 Maximum fluid viscosity 25cSt (mm<sup>2</sup>/s)  
 Ambient temperature : -10°C +40°C  
 Mounting position with vertical coil above

**OPTIONS :** Electroless nickel plating  
 Stainless steel seat

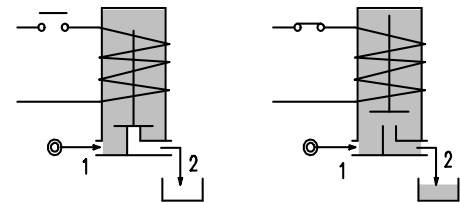
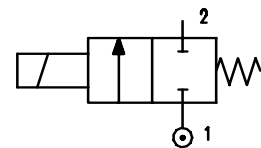

**NOTE:** The solenoid valve is suitable only with media that are **NOT** potentially explosive.

CODE ②	Connection G ISO 228	Orifice mm	KV m <sup>3</sup> /h	Differential pressure bar			Nominal power		Coil Series	Seal	Temperature Range °C
				Min	Max		AC Holding	DC Watt			
					AC	DC					
A106CV30///.....	3/8"	3	0.25	0	15	10	12 VA	8 W	A6	FPM=V	-10 +130
A106CV35///.....		3.5	0.32	0	10	8					
A106CV40///.....		4	0.36	0	8	5					
A106CV45///.....		4.5	0.41	0	6.5	3.5					
A106CV52///.....		5.2	0.47	0	4	1.8					
A106CV64///.....		6.4	0.64	0	3	1					
A106DV30///.....	1/2"	3	0.25	0	15	10	12 VA	8 W	A6	FPM=V	-10 +130
A106DV35///.....		3.5	0.32	0	10	8					
A106DV40///.....		4	0.36	0	8	5					
A106DV45///.....		4.5	0.41	0	6.5	3.5					
A106DV52///.....		5.2	0.47	0	4	1.8					
A106DV64///.....		6.4	0.64	0	3	1					

② Coil

COILS	Alternating Current ~50/60Hz Volt				Direct Current Volt			Electrical connection
	24	48	110	220 230	12	24	48	
Series <b>A6</b> Code ②	A6B	A6C	A6D	A6E	A60	A61	A62	1/2" NPT

**DESCRIPTION**  
 Voltage tolerance  
 AC +15% -10%  
 DC ± 10%  
 Protection class IP66

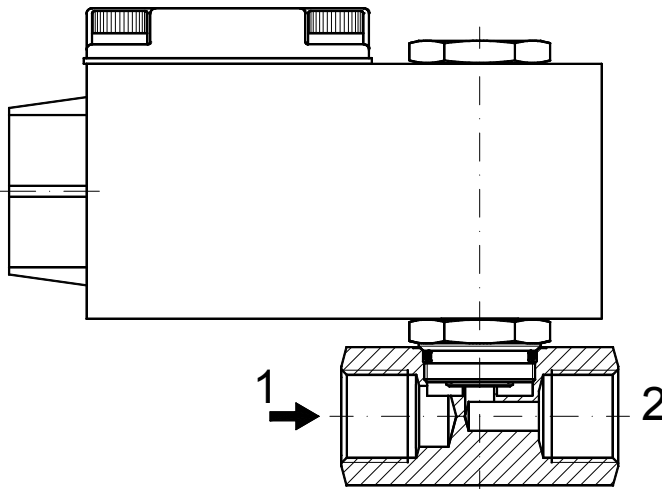

### OVERALL DIMENSION

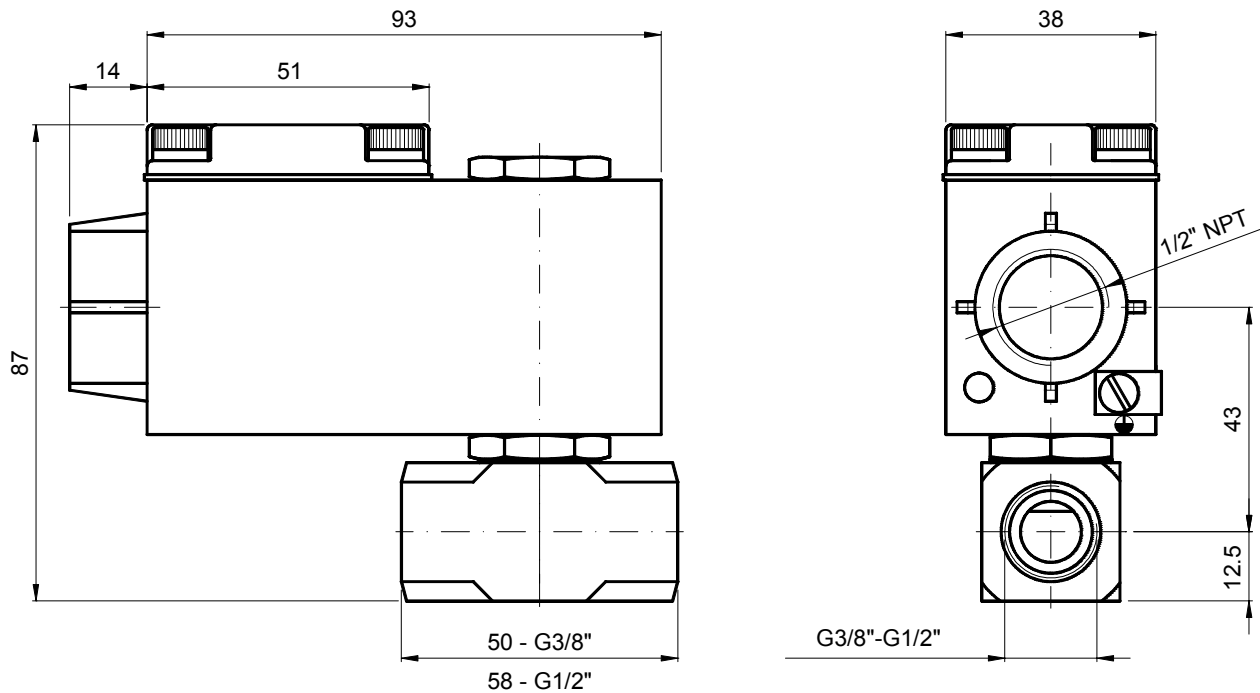

Weight = 0.66 Kg

**DESCRIPTION**

Drain valve

**CONSTRUCTION**

Solenoid valve series 106 with:

- Filter ball in chromium plated brass and stainless steel strainer, NBR seal
- Connection : inlet G1/2", outlet G3/8" or G1/2"
- Timer ACL mod.11303000
- Connector DIN 43650A code 1034900A



**2**

**FEATURES**

- Maximum allowable pressure 80 bar
- Maximum fluid viscosity 25cSt (mm<sup>2</sup>/s)
- Ambient temperature : with class F coil -10°C +55°C  
with class H coil -10°C +80°C
- Protection class IP65

**OPTIONS :** Electroless nickel plating on the valve body  
Overmoulded DIN cable connector

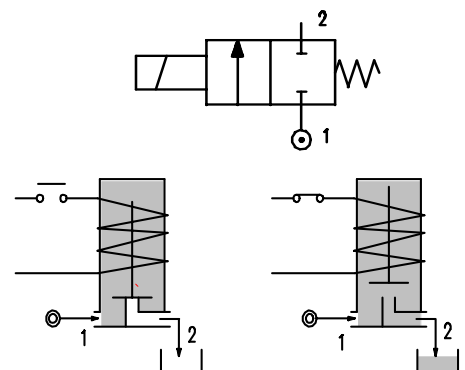

CODE ① ②	Connection G ISO 228	Orifice mm	KV m <sup>3</sup> /h	Differential pressure bar			Nominal power			Coil		Seal ①	Temp. range °C
				Min	Max		AC Inrush	VA Holding	DC Watt	Series	Width		
					AC	DC							
S106BV30///.....	1/4"	3	0.18	0	14	6	20	15	10	2	30	FPM=V	-10 +130
S106BV40///.....		4	0.26	0	7	3							
S106C.....30///.....	3/8"	3	0.25	0	15	10	20	15	10	2	30	NBR=B	-10 +90
S106C.....35///.....		3.5	0.32	0	10	8							
S106C.....40///.....		4	0.36	0	8	5							
S106C.....45///.....		4.5	0.41	0	6.5	3.5							
S106D.....30///.....	1/2"	3	0.25	0	15	10	20	15	10	2	30	NBR=B	-10 +90
S106D.....35///.....		3.5	0.32	0	10	8							
S106D.....40///.....		4	0.36	0	8	5							
S106D.....45///.....		4.5	0.41	0	6.5	3.5							
S106C.....30///.....	3/8"	3	0.25	0	25	24	40	30	27	5	36	NBR=B	-10 +90
S106C.....35///.....		3.5	0.32	0	20	19							
S106C.....40///.....		4	0.36	0	16	15							
S106C.....45///.....		4.5	0.41	0	14	13							
S106D.....30///.....	1/2"	3	0.25	0	25	24	40	30	27	5	36	NBR=B	-10 +90
S106D.....35///.....		3.5	0.32	0	20	19							
S106D.....40///.....		4	0.36	0	16	15							
S106D.....45///.....		4.5	0.41	0	14	13							

- ① Seal
- ② Coil

Example: S106CB25///201 NBR seal  
Coil 24V DC

COILS	Alternating Current ~50/60Hz Volt							Direct Current Volt			Electrical connection	Connectors
	12	24	48	110	220 230	240	380	12	24	48		
Series 2 Width 30 Code ②	20A	20B	20C	20D	20E	20F	20G	200	201	202	DIN 43650A	PG9 code 10349000
Series 5 Width 36 Code ②	52A	52B	52C	52D	52E	52F	52G	521	521	522	DIN 43650A	PG11 code 10349001

**DESCRIPTIONS**  
 Insulation class  
 Series 2=F Series 5=H  
 Voltage tolerance  
 AC +15% -10%  
 DC ± 10%  
 Protection class  
 IP65 with connector fitted  
 IP00 without connector  
 Continuous service ED100%

**OPTIONS**  
 Class H insulation (series 2)  
 Cable attached  
 Special coil voltages  
 Special coil powers

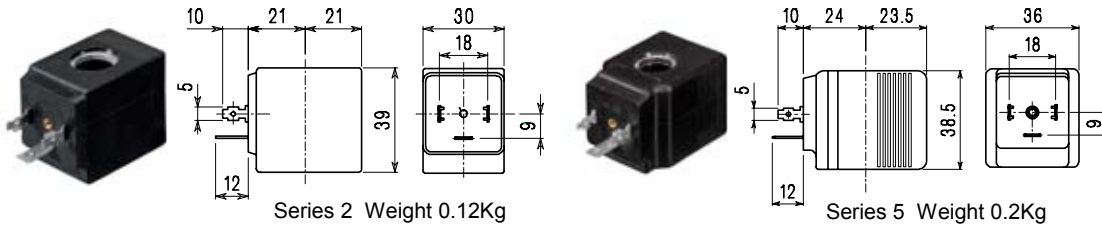

## OVERALL DIMENSION

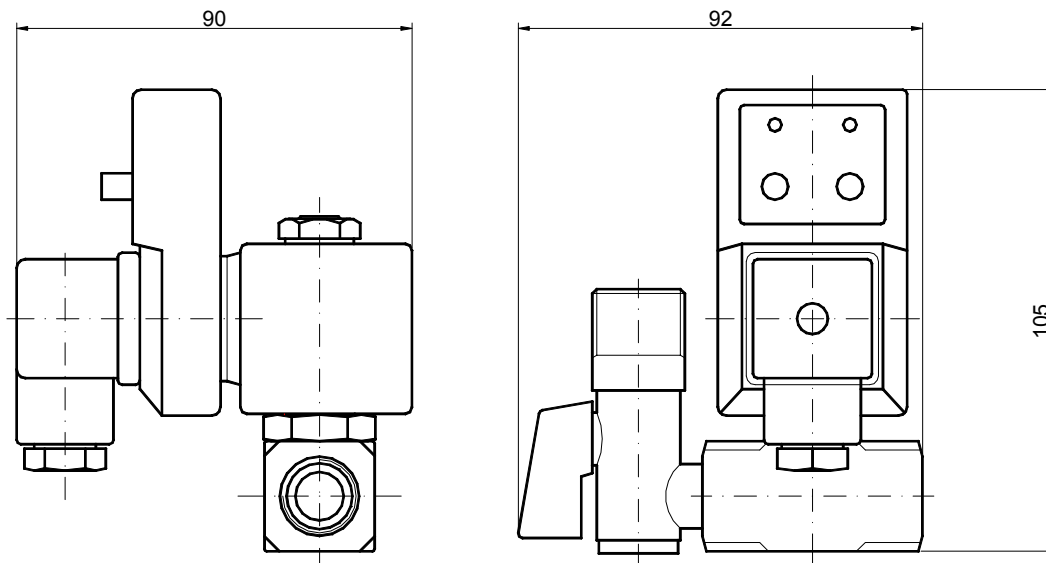

Weight with coil series 2 = 0.52 Kg  
 Weight with coil series 5 = 0.60 Kg

**DESCRIPTION**

Solenoid valve 2 way normally closed  
direct acting poppet type

**CONSTRUCTION**

Body	Brass
Armature tube	Brass
Plunger and core	Stainless steel
Springs	Stainless steel
Seal material	FPM



**2**

**FEATURES**

Maximum allowable pressure 50 bar \*  
 Maximum fluid viscosity 25cSt (mm<sup>2</sup>/s)  
 Ambient temperature : with class F coil -10°C +55°C  
 with class H coil -10°C +80°C  
 Universal mounting position

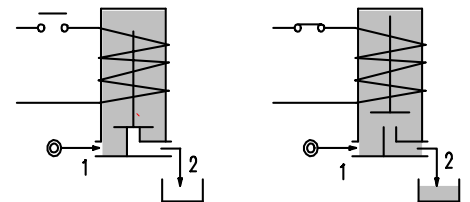
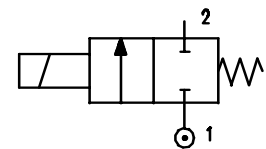

CODE ②	Connection G ISO 228	Orifice mm	KV m <sup>3</sup> /h	Differential pressure bar			Nominal power			Coil		Seal	Temp. range °C
				Min	Max		AC Inrush	VA Holding	DC Watt	Series	Width		
					AC	DC							
W106BV30///.....	1/4"	3	0.18	0	14	6	20	15	10	2	30	FPM=V	-10 +130
W106BV40///.....		4	0.26	0	7	3							

② Coil

\* REMARK: The maximum allowable pressure PS for steam is 2,5bar (gauge pressure)

COIL	Alternating Current ~50/60Hz Volt							Direct Current Volt			Electrical connection	Connectors
	12	24	48	110	220 230	240	380	12	24	48		
Series 2 Width 30 Code ②	20A	20B	20C	20D	20E	20F	20G	200	201	202	DIN 43650A	PG9 code 10349000

**DESCRIPTION**  
 Class F insulation  
 Voltage tolerance  
 AC +15% -10%  
 DC ± 10%  
 Protection class  
 IP65 with connector mounted  
 IP00 without connector  
 Continuous service ED100%

**OPTIONS**  
 Class H insulation  
 Cable attached  
 Special coil voltages  
 Special coil powers

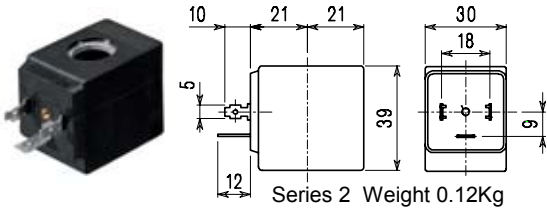

### SPARE PARTS LIST

1. Coil fixing nut
2. Coil
3. Valve

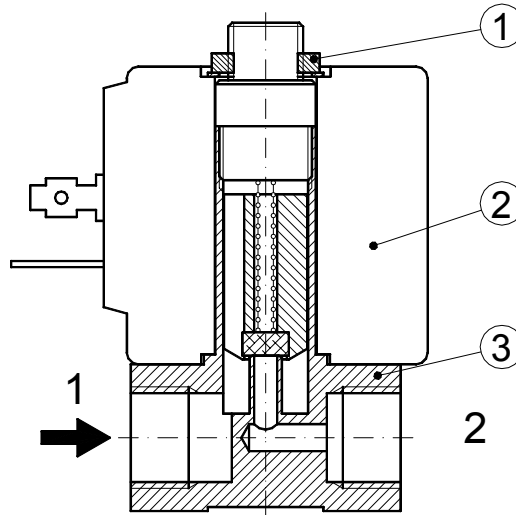

### OVERALL DIMENSION

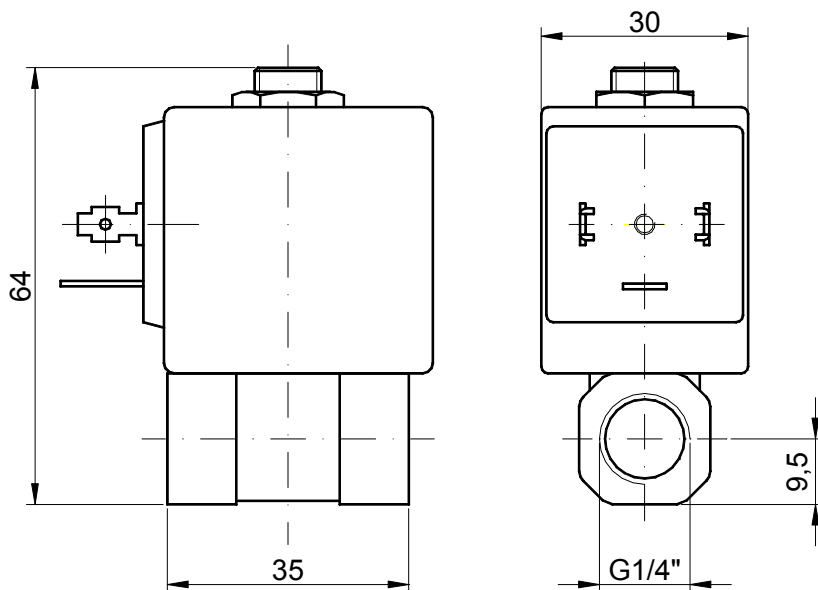

Weight = 0.22 Kg



### DESCRIPTION

Solenoid valve 2 way normally closed  
direct acting poppet type

### CONSTRUCTION

Body	Brass
Armature tube	Stainless steel
Plunger and core	Stainless steel
Springs	Stainless steel
Seal material	NBR
	FPM
	EPDM



2

### FEATURES

Maximum allowable pressure 5 bar  
Maximum fluid viscosity 25cSt (mm<sup>2</sup>/s)  
Ambient temperature : with class F coil -10°C +55°C  
with class H coil -10°C +80°C  
Universal mounting position

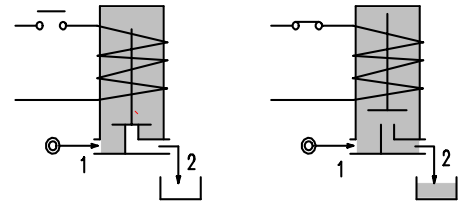
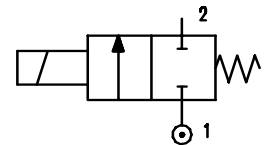

**OPTIONS :** Electroless nickel plating  
Version for use with oxygen

CODE ① ②	Connection G ISO 228	Orifice mm	KV m <sup>3</sup> /h	Differential pressure bar			Nominal power			Coil		Seal ①	Temp. range °C
				Min	Max		AC Inrush	VA Holding	DC Watt	Series	Width		
					AC	DC							
E109C.....12///.....	3/8"	12	2	0	0.5	0.06	20	15	10	2	30	NBR=B	-10 +90
E109D.....12///.....	1/2"	12	2.2	0	0.5	0.06							
E109E.....18///.....	3/4"	18	4.5	0	0.14	--	20	15	--	5	36	EPDM=E	<+140
E109C.....12///.....	3/8"	12	2	0	0.8	0.4							
E109D.....12///.....	1/2"	12	2.2	0	0.8	0.4	40	30	27	5	36	FPM=V	-10 +130
E109E.....18///.....	3/4"	18	4.5	0	0.2	0.12							

- ① Seal
- ② Coil

Example: E109EV18///52B FPM seal  
Coil 24V 50/60Hz

COILS	Alternating Current ~50/60Hz Volt							Direct Current Volt			Electrical connection	Connectors
	12	24	48	110	220 230	240	380	12	24	48		
Series 2 Width 30 Code ②	20A	20B	20C	20D	20E	20F	20G	200	201	202	DIN 43650A	PG9 code 10349000
Series 5 Width 36 Code ②	52A	52B	52C	52D	52E	52F	52G	521	521	522	DIN 43650A	PG11 code 10349001

**DESCRIPTION**  
 Insulation class  
 Series 2=F Series 5=H  
 Voltage tolerance  
 AC +15% -10%  
 DC ± 10%  
 Protection class  
 IP65 with connector fitted  
 IP00 without connector  
 Continuous service ED100%

**OPTIONS**  
 Class H insulation (series 2)  
 Cable attached  
 Special coil voltages  
 Special coil powers

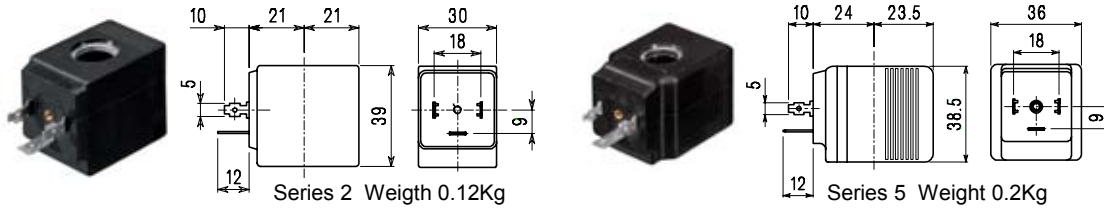

### SPARE PARTS LIST

1. Coil fixing nut
2. Coil
3. Plunger
4. Armature tube with core
5. Body O-Ring

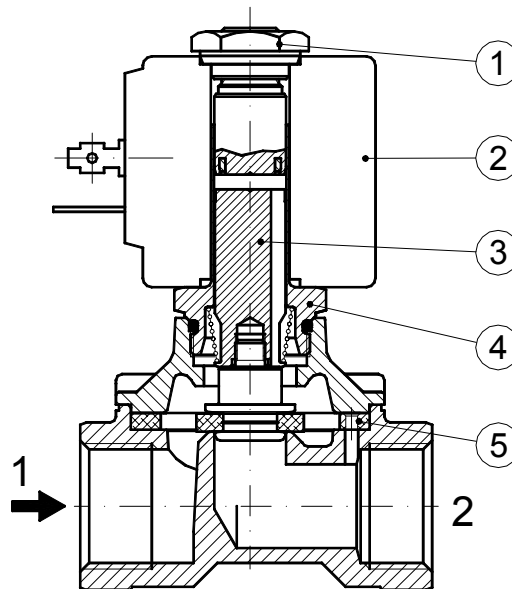

### OVERALL DIMENSION

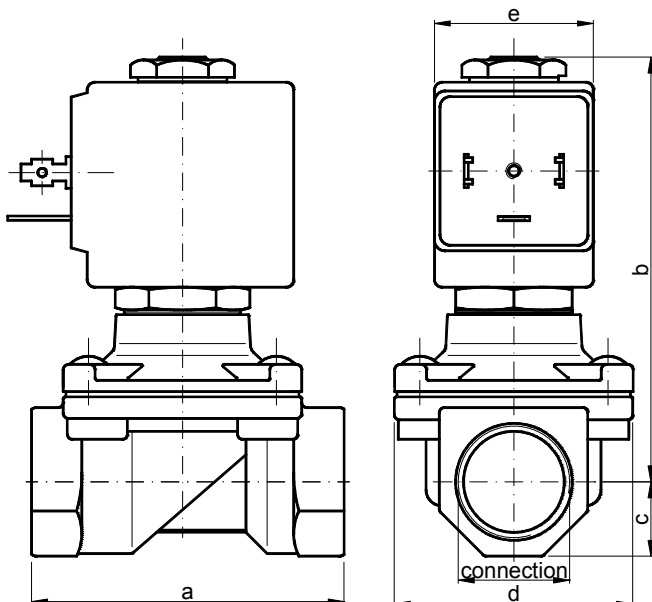

Connection	a	b	c	d	e		Weight kg	
					with series 2	with series 5	series 2	series 5
G3/8"	60	83	14	45	30	36	0.50	0.58
G1/2"	60	83	14	45	30	36	0.45	0.53
G3/4"	75	90	18	55	30	36	0.75	0.83

## DESCRIPTION

Solenoid valve 2 way normally closed  
direct acting poppet type

## CONSTRUCTION

Body	Stainless steel
Armature tube	Stainless steel
Plunger and core	Stainless steel
Springs	Stainless steel
Seal material	NBR FPM EPDM PTFE

## FEATURES

Maximum allowable pressure 100 bar \*  
Maximum fluid viscosity 25cSt (mm<sup>2</sup>/s)  
Ambient temperature : with class F coil -10°C +55°C  
with class H coil -10°C +80°C  
Universal mounting position

**OPTIONS :** Silver shading ring  
For use with oxygen



2

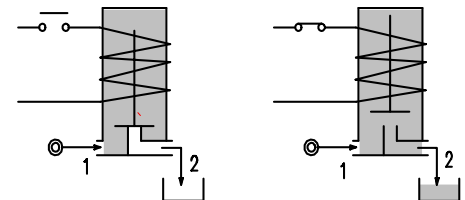
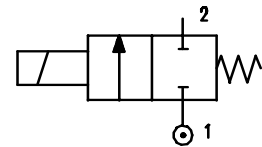

CODE ① ②	Connection G ISO 228	Orifice mm	KV m <sup>3</sup> /h	Differential pressure bar			Nominal power			Coil		Seal ①	Temp. range °C
				Min	Max		AC Inrush	VA Holding	DC Watt	Series	Width		
					AC	DC							
E110B.....20///.....	1/4"	2	0.1	0	22	20	20	15	10	2	30	NBR=B	-10 +90
E110B.....25///.....		2.5	0.15	0	16	14							
E110B.....35///.....		3.5	0.32	0	10	8							
E110B.....45///.....		4.5	0.41	0	6.5	3.5							
E110B.....52///.....		5.2	0.47	0	4	1.8							
E110C.....20///.....	3/8"	2	0.1	0	22	20	20	15	10	2	30	EPDM=E	<+140
E110C.....35///.....		3.5	0.32	0	10	8							
E110C.....52///.....		5.2	0.47	0	4	1.8							
E110C.....64///.....		6.4	0.64	0	3.5	1							
E110D.....20///.....	1/2"	2	0.1	0	22	20	20	15	10	2	30	EPDM=E	<+140
E110D.....35///.....		3.5	0.32	0	10	8							
E110D.....52///.....		5.2	0.47	0	4	1.8							
E110D.....64///.....		6.4	0.64	0	3.5	1							
E110B.....20///.....	1/4"	2	0.1	0	50	40	40	30	27	5	36	FPM=V	-10 +130
E110B.....25///.....		2.5	0.15	0	35	33							
E110B.....35///.....		3.5	0.32	0	20	19							
E110B.....45///.....		4.5	0.41	0	14	13							
E110B.....52///.....		5.2	0.47	0	10	9							
E110C.....20///.....	3/8"	2	0.1	0	50	40	40	30	27	5	36	PTFE=W ③	-10 +160
E110C.....35///.....		3.5	0.32	0	20	19							
E110C.....52///.....		5.2	0.47	0	10	9							
E110C.....64///.....		6.4	0.64	0	5	4.5							
E110D.....20///.....	1/2"	2	0.1	0	50	40	40	30	27	5	36	PTFE=W ③	-10 +160
E110D.....35///.....		3.5	0.32	0	20	19							
E110D.....52///.....		5.2	0.47	0	10	9							
E110D.....64///.....		6.4	0.64	0	5	4.5							

① Seal Example: E110BE35///521 EPDM seal  
② Coil Coil 24V DC

③ Maximum allowable leakage < 0.2 nL/h

\* REMARK: The maximum allowable pressure PS for steam is 6 bar (gauge pressure) with PTFE seals and 2,5bar with EPDM seals

COILS	Alternating Current ~50/60Hz Volt							Direct Current Volt			Electrical connection	Connectors
	12	24	48	110	220 230	240	380	12	24	48		
Series 2 Width 30 Code ②	20A	20B	20C	20D	20E	20F	20G	200	201	202	DIN 43650A	PG9 code 10349000
Series 5 Width 36 Code ②	52A	52B	52C	52D	52E	52F	52G	521	521	522	DIN 43650A	PG11 code 10349001

**DESCRIPTION**  
 Insulation class  
 Series 2=F Series 5=H  
 Voltage tolerance  
 AC +15% -10%  
 DC ± 10%  
 Protection class  
 IP65 with connector fitted  
 IP00 without connector  
 Continuous service ED100%

**OPTIONS**  
 Class H insulation (series 2)  
 Cable attached  
 Special coil voltages  
 Special coil powers

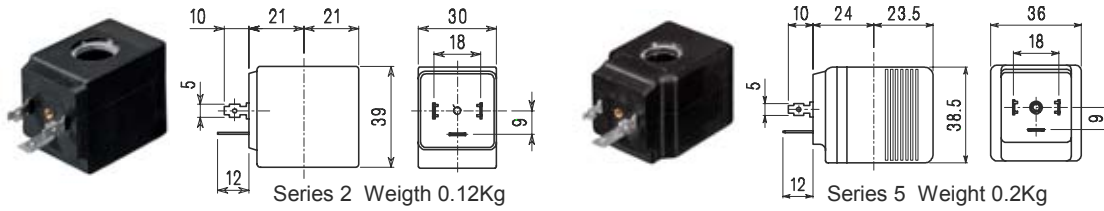

### SPARE PARTS LIST

1. Coil fixing nut
2. Coil
3. Plunger
4. Armature tube with core

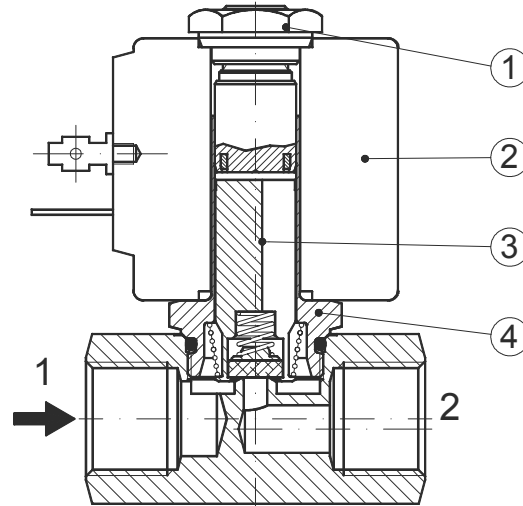

### OVERALL DIMENSION

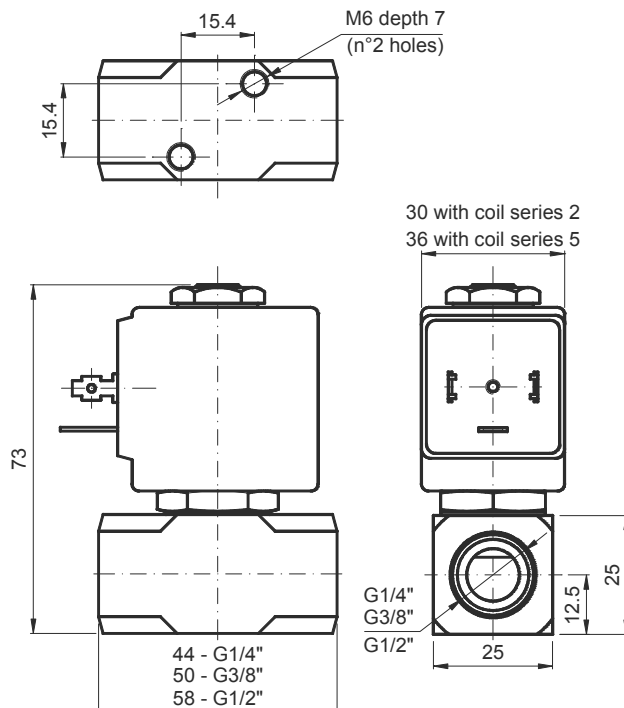

Weight with coil series 2 = 0.36 Kg  
 Weight with coil series 5 = 0.44 Kg

**DESCRIPTION**

Solenoid valve 2 way normally closed  
 direct acting poppet type.  
 With explosion proof coil certified:  
 CESI 03 ATEX 344 ExII2G/D Eex "d" IIC T6

**VALVE CONSTRUCTION**

Body                                      Stainless steel  
 Seal material                         FPM

**EXPLOSION PROOF CONSTRUCTION**

Housing                                 Red colour alloy  
 Electrical connection             ½" NPT

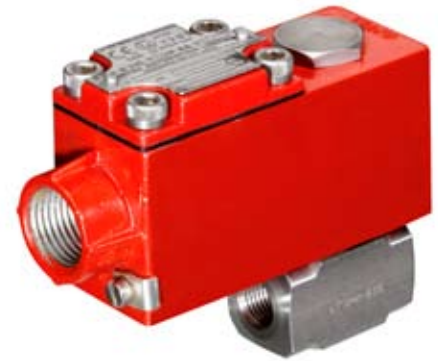

**2**

**FEATURES**

Maximum allowable pressure 100 bar  
 Maximum fluid viscosity < 25cSt (mm<sup>2</sup>/s)  
 Ambient temperature :   -10°C +40°C  
 Universal mounting position

**OPTIONS :** Silver shading ring

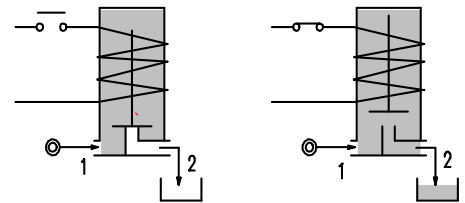
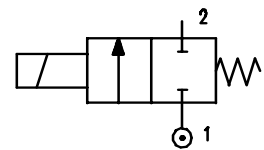

**NOTE:** The solenoid valve is suitable only with media that are **NOT** potentially explosive.

CODE ②	Connection G ISO 228	Orifice mm	KV m³/h	Differential pressure bar			Nominal power		Coil Series	Seal	Temperature range °C
				Min	Max		AC Holding	DC Watt			
					AC	DC					
A110BV20///.....	1/4"	2	0.1	0	22	20	12 VA	8 W	A6	FPM=V	-10 +130
A110BV25///.....		2.5	0.15	0	16	14					
A110BV35///.....		3.5	0.32	0	10	8					
A110BV45///.....		4.5	0.41	0	6.5	3.5					
A110BV52///.....		5.2	0.47	0	4	1.8					
A110BV64///.....	6.4	0.64	0	3.5	1						
A110CV20///.....	3/8"	2	0.1	0	22	20					
A110CV35///.....		3.5	0.32	0	10	8					
A110CV52///.....		5.2	0.47	0	4	1.8					
A110CV64///.....		6.4	0.64	0	3.5	1					
A110DV20///.....	1/2"	2	0.1	0	22	20					
A110DV35///.....		3.5	0.32	0	10	8					
A110DV52///.....		5.2	0.47	0	4	1.8					
A110DV64///.....		6.4	0.64	0	3.5	1					

② Coil

COILS	Alternating Current ~50/60Hz Volt				Direct Current Volt			Electrical connection
	24	48	110	220 230	12	24	48	
Series <b>A6</b> Code ②	A6B	A6C	A6D	A6E	A60	A61	A62	1/2" NPT

**DESCRIPTION**  
 Voltage tolerance  
 AC +15% -10%  
 DC ± 10%  
 Protection class IP66

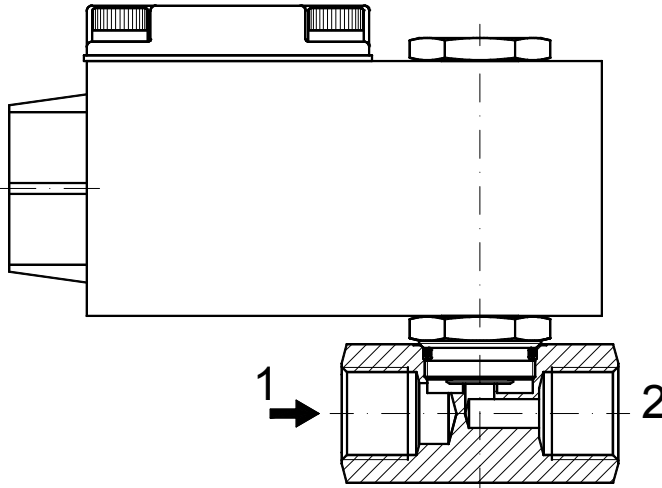

### OVERALL DIMENSION

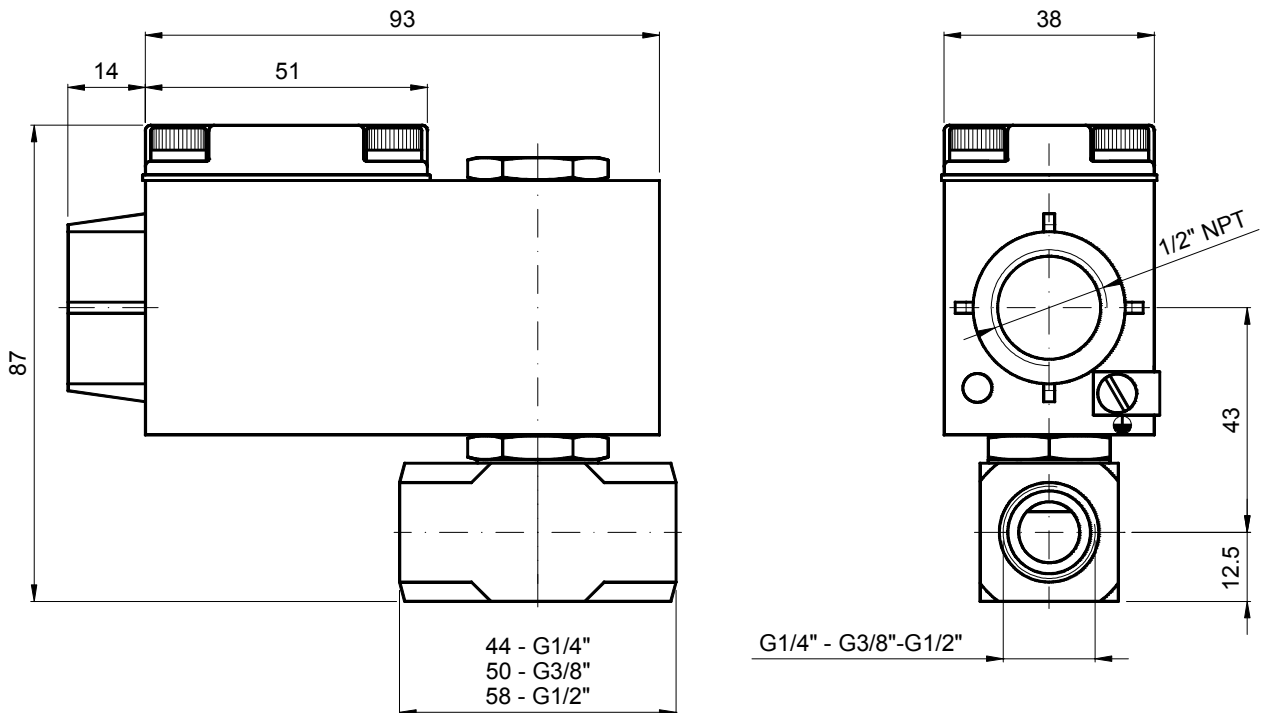

Weight = 0.66 Kg

## DESCRIPTION

Solenoid valve 2 way normally closed  
direct acting poppet type

## CONSTRUCTION

Body	Stainless steel
Armature tube	Stainless steel
Plunger and core	Stainless steel
Springs	Stainless steel
Seal material	NBR
	FPM
	EPDM



2

## FEATURES

Maximum allowable pressure 50 bar \*  
Maximum fluid viscosity 25cSt (mm<sup>2</sup>/s)  
Ambient temperature : with class F coil -10°C +55°C  
with class H coil -10°C +80°C  
Universal mounting position

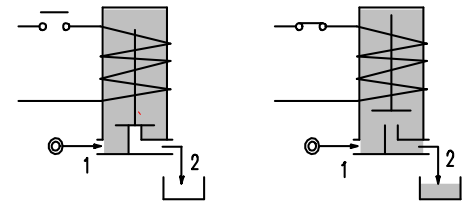
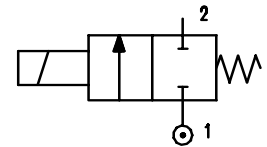

**OPTIONS :** Silver shading ring  
Explosion proof coil according  
to ATEX - EExmII Series7  
For use with oxygen

CODE ① ②	Connection G ISO 228	Orifice mm	KV m <sup>3</sup> /h	Differential pressure bar			Nominal power			Coil		Seal ①	Temp. range °C
				Min	Max		AC Inrush	VA Holding	DC Watt	Series	Width		
					AC	DC							
E111A.....12///.....	1/8"	1.2	0.04	0	25	25	12	8	6.5	3	22	NBR=B EPDM=E FPM=V	-10 +90 <+140 -10 +130
E111A.....15///.....		1.5	0.06	0	16	16							
E111A.....20///.....		2	0.09	0	12	10							
E111A.....25///.....		2.5	0.14	0	8	5.5							
E111A.....31///.....		3.1	0.19	0	5	2	15	11	5	4	30		
E111A.....20///.....		2	0.09	0	25	15							
E111A.....25///.....		2.5	0.14	0	16	8							
E111A.....31///.....		3.1	0.19	0	8	4							

① Seal

② Coil

Example: E111AB20///30B NBR seal

Coil 24V 50/60Hz

\* REMARK: The maximum allowable pressure PS for steam is 2,5bar (gauge pressure)

COILS	Alternating Current ~50/60Hz Volt							Direct Current Volt			Electrical connection	Connectors
	12	24	48	110	220 230	240	380	12	24	48		
Series 3 Width 22 Code ②	30A	30B	30C	30D	30E	30F	30G	300	301	302	DIN 46244	PG9 code 10348000
Series 4 Width 30 Code ②	40A	40B	40C	40D	40E	40F	40G	400	401	402	DIN 43650A	PG9 code 10349000

**DESCRIPTION**  
 Class F insulation  
 Voltage tolerance  
 AC +15% -10%  
 DC ± 10%  
 Protection class  
 IP65 with connector fitted  
 IP00 without connector  
 Continuous service ED100%

**OPTIONS**  
 Class H insulation  
 Cable attached  
 Special coil voltages  
 Special coil powers

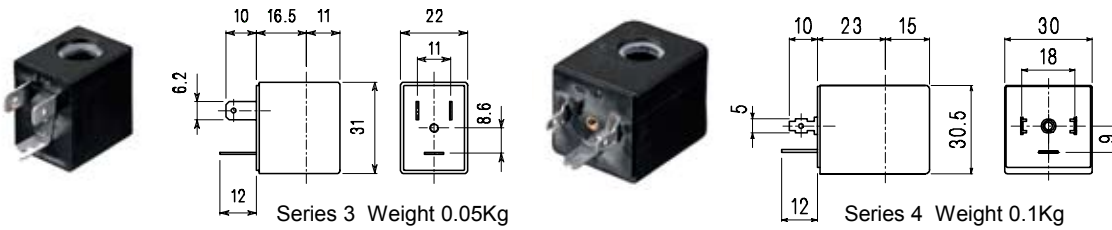

### SPARE PARTS LIST

1. Coil fixing nut
2. Coil
3. Plunger
4. Armature tube with core

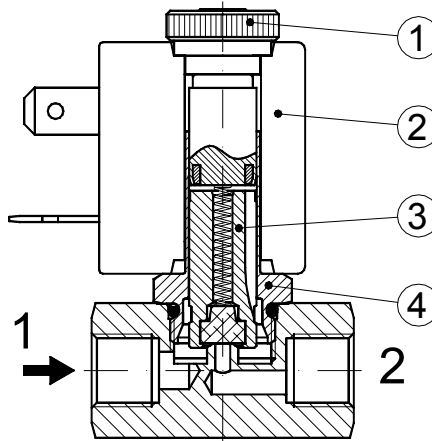

### OVERALL DIMENSION

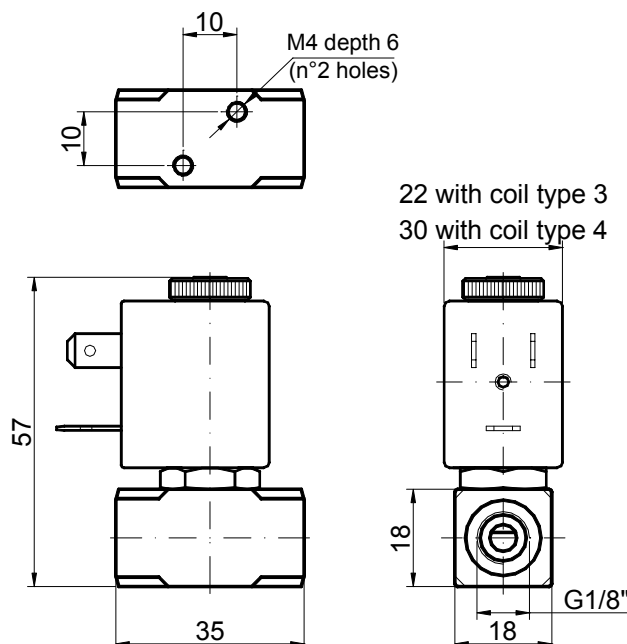

Weight with coil series 3 = 0.15 Kg  
 Weight with coil series 4 = 0.20 Kg



## DESCRIPTION

Solenoid valve 2 way normally close  
direct acting poppet type

## CONSTRUCTION

Body	Brass
Armature tube	Brass
Plunger and core	Stainless steel
Springs	Stainless steel
Seal material	NBR
	FPM
	EPDM



2

## FEATURES

Maximum allowable pressure 50 bar \*  
Maximum fluid viscosity 25cSt (mm<sup>2</sup>/s)  
Ambient temperature : with class F coil -10°C +55°C  
with class H coil -10°C +80°C  
Universal mounting position

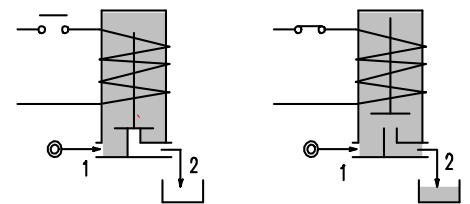
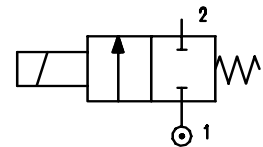

**OPTIONS :** Stainless steel armature tube  
Electroless nickel plating  
Explosion proof coil according  
to ATEX - EExmII Series7

CODE ① ②	Flange	Orifice mm	KV m <sup>3</sup> /h	Differential pressure bar			Nominal power			Coil		Seal ①	Temp. range °C
				Min	Max		AC Inrush	VA Holding	DC Watt	Series	Width		
					AC	DC							
E112X.....12///.....	Q 25	1.2	0.04	0	25	25	12	8	6.5	3	22	NBR=B	-10 +90
E112X.....15///.....		1.5	0.06	0	16	16						EPDM=E	<+140
E112X.....20///.....		2	0.09	0	12	10							
E112X.....25///.....		2.5	0.14	0	8	5.5	15	11	5	4	30	FPM=V	-10 +130
E112X.....20///.....		2	0.09	0	25	15							
E112X.....25///.....		2.5	0.14	0	16	8							

- ① Seal
- ② Coil

Example: E112XB20///30B NBR seal  
Coil 24V 50/60Hz

Solenoid valve supplied without fixing screws

\* REMARK: The maximum allowable pressure PS for steam is 2,5bar (gauge pressure)

COILS	Alternating Current ~50/60Hz Volt							Direct Current Volt			Electrical Connection	Connectors
	12	24	48	110	220 230	240	380	12	24	48		
Series 3 Width 22 Code ②	30A	30B	30C	30D	30E	30F	30G	300	301	302	DIN 46244	PG9 code 10348000
Series 4 Width 30 Code ②	40A	40B	40C	40D	40E	40F	40G	400	401	402	DIN 43650A	PG9 code 10349000

**DESCRIPTION**  
 Class F insulation  
 Voltage tolerance  
 AC +15% -10%  
 DC ± 10%  
 Protection class  
 IP65 with connector fitted  
 IP00 without connector  
 Continuous service ED100%

**OPTIONS**  
 Class H insulation  
 Cable attached  
 Special coil voltages  
 Special coil powers

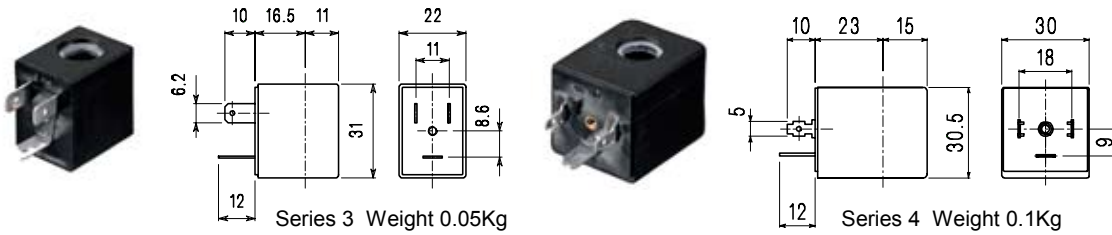

### SPARE PARTS LIST

1. Coil fixing nut
2. Coil
3. Plunger
4. Armature tube with core

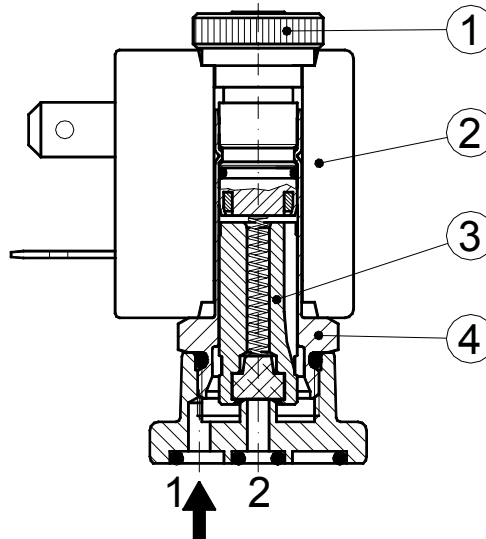

### OVERALL DIMENSION

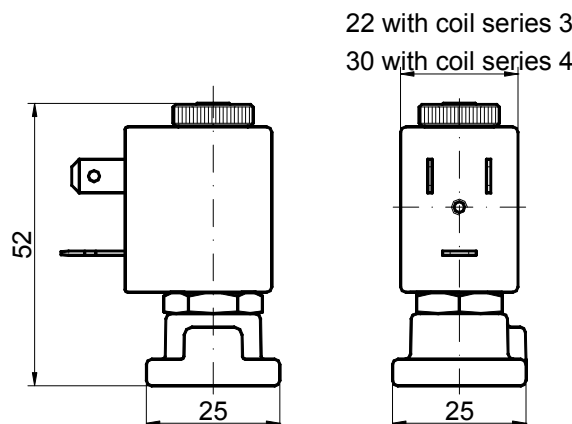
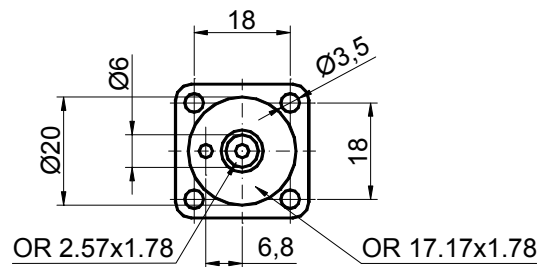

Weight with coil series 3 = 0.12 Kg  
 Weight with coil series 4 = 0.17 Kg

## DESCRIPTION

Solenoid valve 2 way normally closed  
direct acting poppet type

## CONSTRUCTION

Body	Brass
Armature tube	Stainless steel
Plunger and core	Stainless steel
Springs	Stainless steel
Seal material	NBR
	FPM
	EPDM
	PTFE



2

## FEATURES

Maximum allowable pressure 50 bar \*  
Maximum fluid viscosity 25cSt (mm<sup>2</sup>/s)  
Ambient temperature : with class F coil -10°C +55°C  
with class H coil -10°C +80°C  
Universal mounting position

**OPTIONS :** Manual override  
Electroless nickel plating  
Stainless steel seat

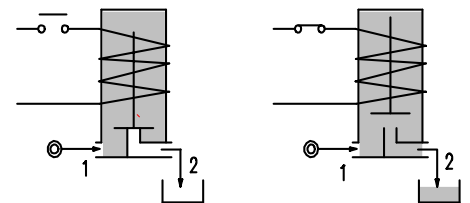
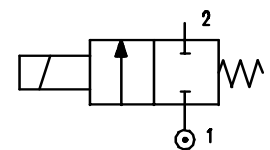

CODE ① ②	Flange	Orifice mm	KV m <sup>3</sup> /h	Differential pressure bar		Nominal power			Coil		Seal ①	Temp. range °C	
				Min	Max		AC Inrush	VA Holding	DC Watt	Series			Width
					AC	DC							
E114X.....15///.....	Q 32	1.5	0.07	0	30	26	20	15	10	2	30	NBR=B EPDM=E FPM=V PTFE=W ③	-10 +90  +140  -10 +130  -10 +160
E114X.....20///.....		2	0.1	0	22	20							
E114X.....25///.....		2.5	0.15	0	16	14							
E114X.....35///.....		3.5	0.32	0	10	8							
E114X.....45///.....		4.5	0.41	0	6.5	3.5							
E114X.....52///.....		5.2	0.47	0	4	1.8							
E114X.....25///.....		2.5	0.15	0	35	33	40	30	27	5	36		
E114X.....35///.....		3.5	0.32	0	20	19							
E114X.....45///.....		4.5	0.41	0	14	13							
E114X.....52///.....		5.2	0.47	0	10	9							

- ① Seal Example: E114XB25///20E NBR seal
- ② Coil Coil 220V 50/60Hz
- ③ Maximum allowable leakage < 0.2nL/h

Solenoid valve supplied without fixing screws

\* REMARK: The maximum allowable pressure PS for steam is 2,5bar (gauge pressure)

COILS	Alternating Current ~50/60Hz Volt							Direct Current Volt			Electrical connection	Connectors
	12	24	48	110	220 230	240	380	12	24	48		
Series 2 Width 30 Code ②	20A	20B	20C	20D	20E	20F	20G	200	201	202	DIN 43650A	PG9 code 10349000
Series 5 Width 36 Code ②	52A	52B	52C	52D	52E	52F	52G	521	521	522	DIN 43650A	PG11 code 10349001

**DESCRIPTION**  
 Insulation class  
 Series 2=F Series 5=H  
 Voltage tolerance  
 AC +15% -10%  
 DC ± 10%  
 Protection class  
 IP65 with connector fitted  
 IP00 without connector  
 Continuous service ED100%

**OPTIONS**  
 Class H insulation (series 2)  
 Cable attached  
 Special coil voltages  
 Special coil powers

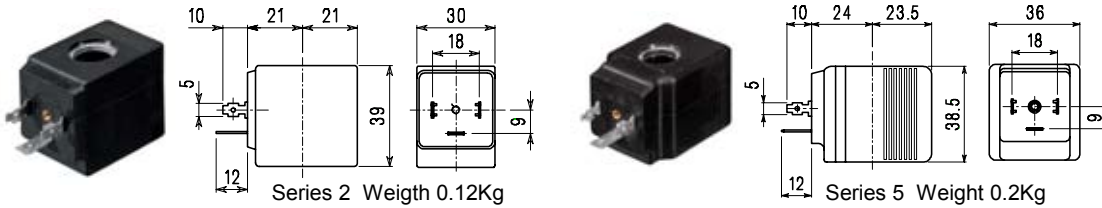

### SPARE PARTS LIST

1. Coil fixing nut
2. Coil
3. Plunger
4. Armature tube with core

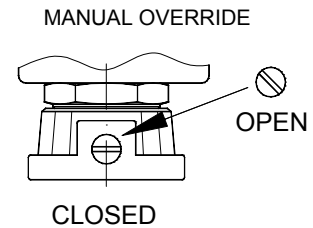
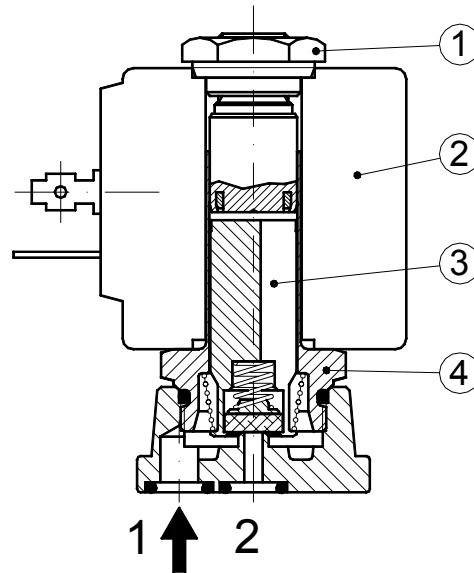

### OVERALL DIMENSION

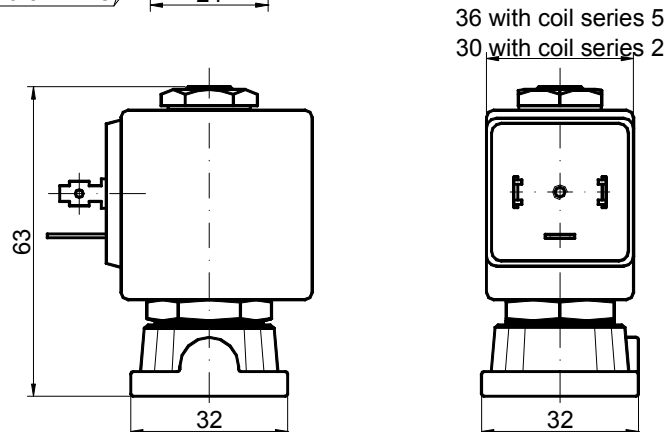
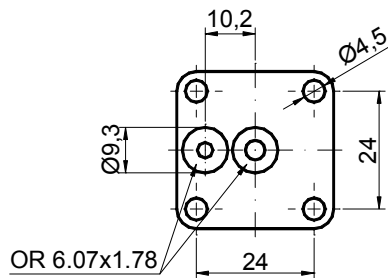

Weight with coil series 2 = 0.24 Kg  
 Weight with coil series 5 = 0.32 Kg

**DESCRIPTION**

Solenoid valve 2 way direct acting poppet type . Bi-stable impulse drive. The bi-stable function is achieved by the use of a polarised permanent magnet energising the coil with a DC current for at least 15ms in the reverse direction of the preceding impulse.



**2**

**CONSTRUCTION**

Body	Brass
Armature tube	Brass
Plunger and core	Stainless steel
Magnet	NeFeB
Springs	Stainless steel
Seal material	NBR FPM EPDM

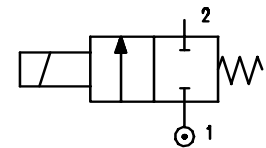

**FEATURES**

Maximum allowable pressure 50 bar  
 Maximum fluid viscosity 25cSt (mm<sup>2</sup>/s)  
 Ambient temperature : with class F coil -10°C +55°C  
 with class H coil -10°C +80°C  
 Universal mounting position

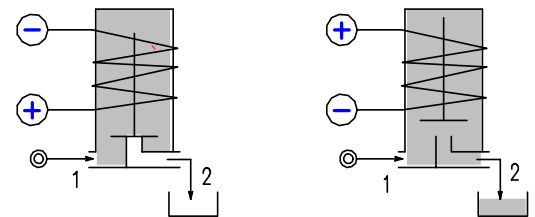

**OPTIONS :** Armature tube in stainless steel  
 Electroless nickel plating  
 Explosion proof coil according to ATEX - EExmII Series7  
 Special powers

CODE ① ②	Connection G ISO 228	Orifice mm	KV m <sup>3</sup> /h	Differential pressure bar		Nominal power DC Watt	Coil		Seal ①	Temp. range °C	
				Min	Max		Series	Width			
D115A.....12///.....	1/8"	1.2	0.04	0	12	2	3	22	NBR=B	-10 +90	
D115A.....15///.....	1/8"	1.5	0.06	0	8	2					
D115A.....20///.....	1/8"	1.5	0.06	0	20	5					
		2	0.09	0	3	2					
D115A.....25///.....	1/8"	2	0.09	0	12	5					
		2.5	0.14	0	1	2					
		2.5	0.14	0	5	5					
D115A.....31///.....	1/8"	2.5	0.14	0	8	6.5					
		3.1	0.19	0	2	5					
		3.1	0.19	0	3.5	6.5				FPM=V	-10 +120

- ① Seal
- ② Coil

Example: D115AE20///300120 EPDM seal  
 Coil 12V DC 2W

COIL	DIRECT CURRENT															Electrical connection	Connectors
	3V			6V			9V			12V			24V				
	2W	5W	6.5W	2W	5W	6.5W	2W	5W	6.5W	2W	5W	6.5W	2W	5W	6.5W		
Series 3 Width 22 Code ②	308120			305120	305150		307120	307150		300120	300150	300	301120	301150	301	DIN 46244	PG9 code 10348000

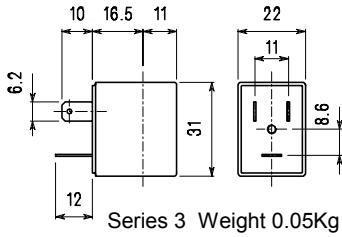

**DESCRIPTION**  
 Class F insulation  
 Voltage tolerance  $\pm 10\%$   
 Protection class  
 IP65 with connector fitted  
 IP00 without connector

**OPTIONS**  
 Class H insulation  
 Cable attached  
 Special coil powers  
 Special coil voltages

**SPARE PARTS LIST**

- 1. Coil fixing nut
- 2. Coil
- 3. Plunger
- 4. Armature tube with core

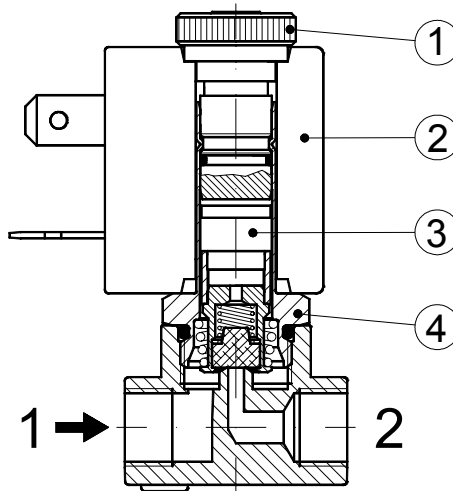

**OVERALL DIMENSION**

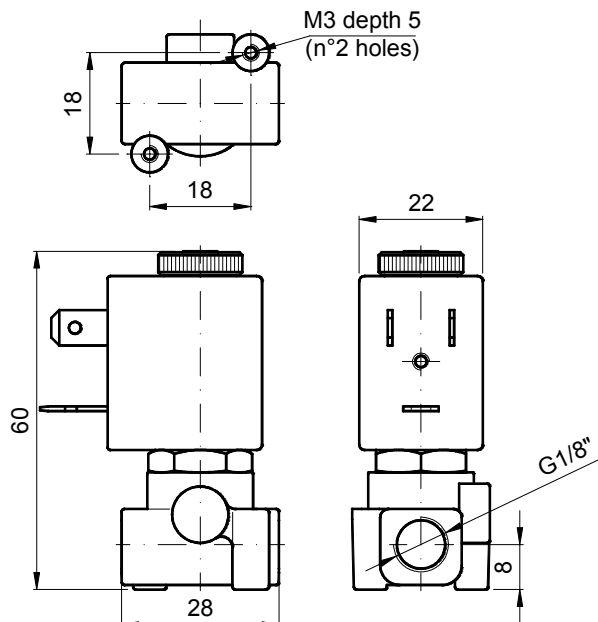

Weight = 0.14 Kg

**DESCRIPTION**

Solenoid valve 2 way direct acting poppet type . Bi-stable impulse drive. The bi-stable function is achieved by the use of a polarised permanent magnet energising the coil with a DC current for at least 15ms in the reverse direction of the preceding impulse.



**2**

**CONSTRUCTION**

Body	Brass
Armature tube	Stainless steel
Plunger and core	Stainless steel
Magnet	NeFeB
Springs	Stainless steel
Seal	NBR
	FPM
	EPDM

**FEATURES**

Maximum allowable pressure 50 bar \*  
 Maximum fluid viscosity 25cSt (mm<sup>2</sup>/s)  
 Ambient temperature : with class F coil -10°C +55°C  
 with class H coil -10°C +80°C  
 Universal mounting position

**OPTIONS :** Stainless steel seat insert  
 Electroless nickel plating  
 Special powers

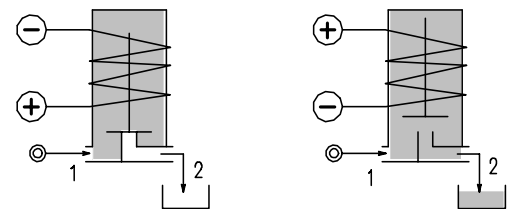
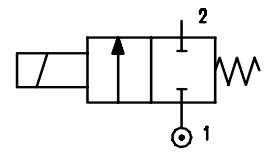

CODE ① ②	Connection G ISO 228	Orifice mm	KV m <sup>3</sup> /h	Differential pressure bar			Nominal power			Coil		Seal ①	Temp. range °C
				Min	Max		AC Inrush	VA Holding	DC Watt	Series	Width		
					AC	DC							
D116A.....15///.....	1/8"	1.5	0.07	0	-	26	-	-	10	2	30	NBR=B	-10 +90
D116A.....20///.....		2	0.1	0	-	20							
D116A.....25///.....		2.5	0.15	0	-	14							
D116A.....35///.....		3.5	0.32	0	-	8							
D116B.....15///.....	1/4"	1.5	0.07	0	-	26							
D116B.....20///.....		2	0.1	0	-	20							
D116B.....25///.....		2.5	0.15	0	-	14							
D116B.....35///.....		3.5	0.32	0	-	8							
D116B.....45///.....		4.5	0.41	0	-	3.5							
D116B.....52///.....	5.2	0.47	0	-	1.8								
D116C.....30///.....	3/8"	3	0.25	0	-	10							
D116C.....35///.....		3.5	0.32	0	-	8							
D116C.....40///.....		4	0.36	0	-	5							
D116C.....45///.....		4.5	0.41	0	-	3.5							
D116C.....52///.....		5.2	0.47	0	-	1.8							
D116D.....30///.....	1/2"	3	0.25	0	-	10							
D116D.....35///.....		3.5	0.32	0	-	8							
D116D.....40///.....		4	0.36	0	-	5							
D116D.....45///.....		4.5	0.41	0	-	3.5							
D116D.....52///.....		5.2	0.47	0	-	1.8							

① Seal Example: D116BB25///201 NBR seal  
 ② Coil Coil 24V DC

\* REMARK: The maximum allowable pressure PS for steam is 2,5 bar (gauge pressure) with EPDM seals

COIL	Direct Current Volt			Electrical connection	Connectors
	12	24	48		
Series 2 Width 30 Code ②	200	201	202	DIN 43650A	PG9 code 10349000

**DESCRIPTION**  
 Insulation class F  
 Voltage tolerance  $\pm 10\%$   
 Protection class  
 IP65 with connector fitted  
 IP00 without connector

**OPTIONS**  
 Class H insulation  
 Cable attached  
 Special coil voltages  
 Special coil powers

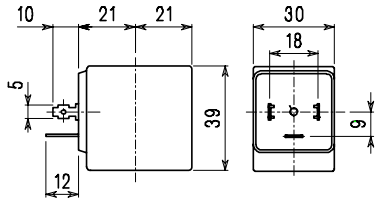

Series 2 Weight 0.12Kg

### SPARE PARTS LIST

1. Coil fixing nut
2. Coil
3. Plunger assembly
4. Armature tube assembly

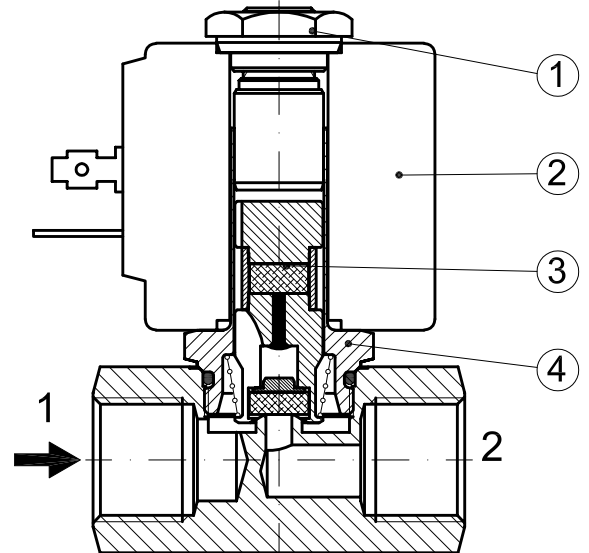
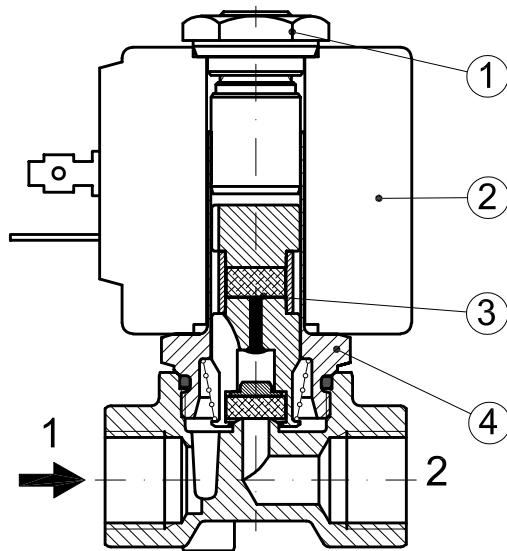

### OVERALL DIMENSION

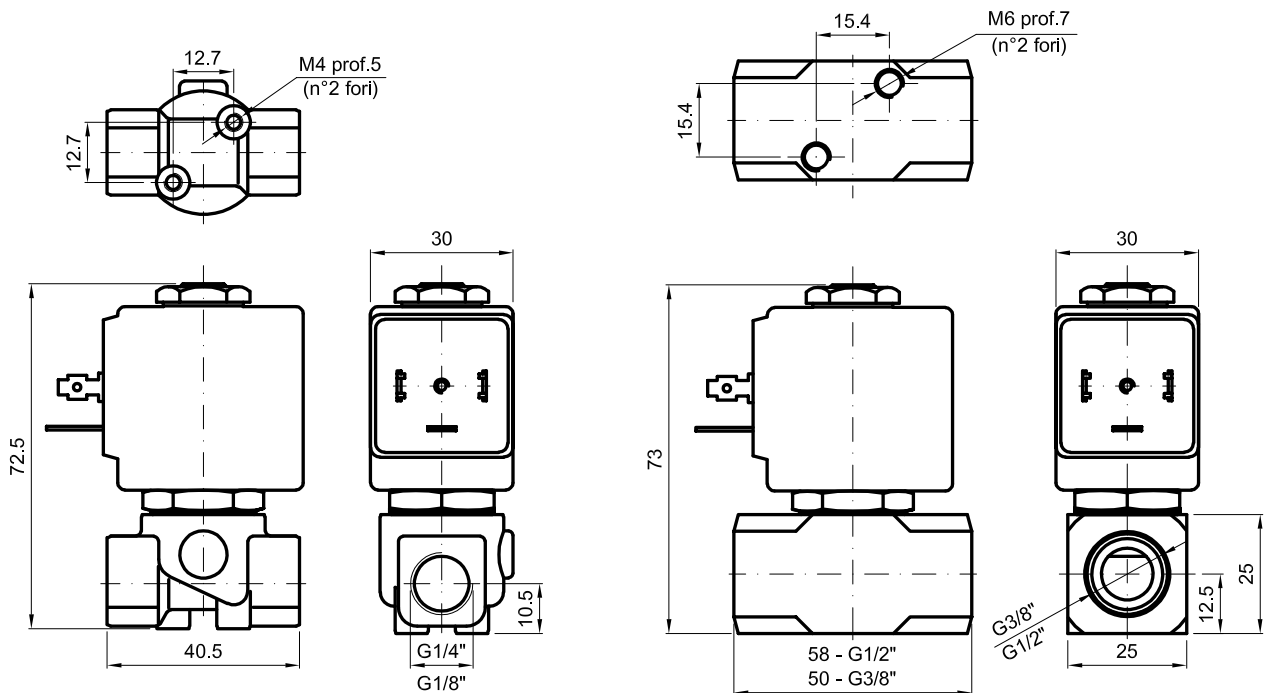



**DESCRIPTION**

Solenoid valve 2 way normally closed  
direct acting poppet type

**CONSTRUCTION**

Body	Brass
Armature tube	Brass
Plunger and core	Stainless steel
Springs	Stainless steel
Seal material	NBR FPM



**2**

**FEATURES**

Maximum allowable pressure 30 bar  
Maximum fluid viscosity 25cSt (mm<sup>2</sup>/s)  
Ambient temperature : with class F coil -10°C +55°C  
with class H coil -10°C +80°C  
Universal mounting position

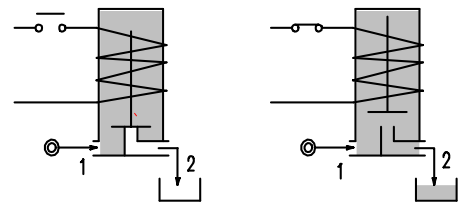
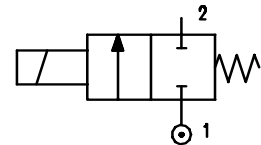

**OPTIONS :** Electroless nickel plating

CODE ① ②	Connection	Orifice mm	KV m <sup>3</sup> /h	Differential pressure bar			Nominal power			Coil		Seal ①	Temp. Range °C
				Min	Max		AC Inrush	VA Holding	DC Watt	Series	Width		
					AC	DC							
D121L.....10///.....	M5	1	0.03	0	-	10	-	-	2	6	16	NBR=B	-10 +90
D121L.....12///.....		1.2	0.037	0	-	7	-	-	2				
D121L.....12///.....		1.2	0.037	0	-	12	-	-	4				
D121L.....16///.....		1.6	0.055	0	-	3	-	-	2				
D121L.....16///.....		1.6	0.055	0	-	8	-	-	4				
D121L.....20///.....		2	0.082	0	-	1.4	-	-	2				
D121L.....20///.....		2	0.082	0	-	4	-	-	4			FPM=V	

- ① Seal
- ② Coil

Example: D121LV12///60112 FPM seal  
Coil 24V DC 2W

COIL	Direct Current				Electrical connection	Connectors
	12V		24V			
	2W	4W	2W	4W		
Series 6 Width 16 Code ②	60012	60014	60112	60114	AMP 2.8X0.5	PG7 10348040

**DESCRIPTION**  
 Class F insulation  
 Voltage tolerance  $\pm 5\%$   
 Protection class  
 IP65 with connector fitted  
 IP00 without connector  
 Continuous service ED100%

**OPTIONS**  
 Cable attached  
 Special coil voltages  
 Special coil powers

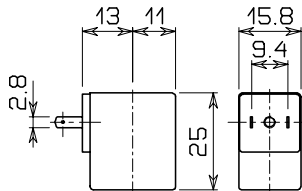

Series 6 Weight 0.02Kg

**SPARE PARTS LIST**

1. Coil fixing nut
2. Coil
3. Plunger
4. Armature tube with core

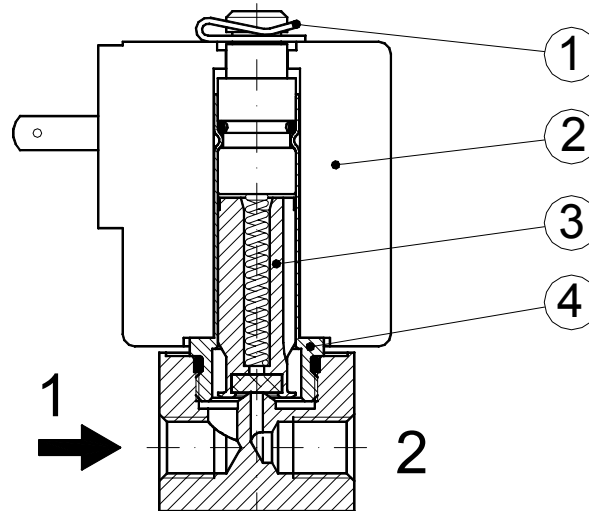

**OVERALL DIMENSION**

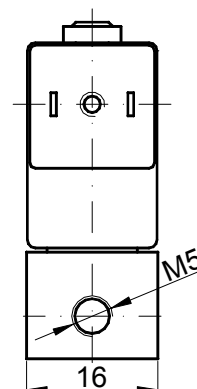
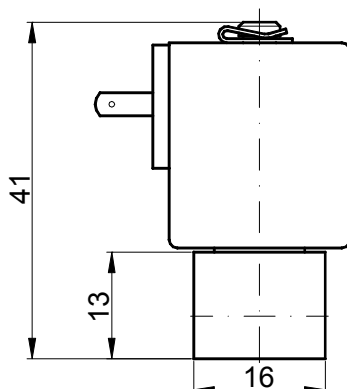
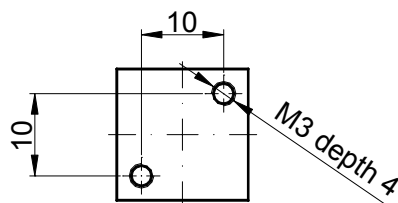

Weight = 0.05 Kg

### DESCRIPTION

Solenoid valve 2 way normally closed direct acting poppet type, suitable for food application and all compatible fluids.

### CONSTRUCTION

Body	Thermoplastic polymer: NSF, WRC, KTW, FDA certified
Armature tube	Brass chemically nickel plated
Plunger and core	Stainless steel
Springs	Stainless steel
Seal material	NBR food contact certified FPM food contact certified EPDM food contact certified



2

### FEATURES

- Maximum allowable pressure 30 bar \*
- Maximum fluid viscosity 25cSt (mm<sup>2</sup>/s)
- Ambient temperature : with class F coil -10°C +55°C  
with class H coil -10°C +80°C
- Universal mounting position

- OPTIONS :** Stainless steel armature tube  
Type N connection without nut

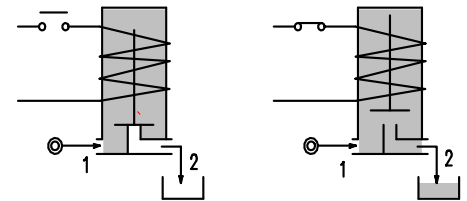
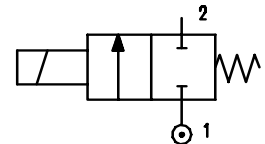

CONNECTIONS					
K	N	P	W ③	Y	Z
<b>SPIGGOT</b>	<b>G1/8" male thread</b> with <b>NUT</b> for flexible and semiflexible pipes	<b>HOSETAIL</b> for flexible pipes	<b>COMPRESSION</b> for flexible and semiflexible pipes	<b>PUSH IN</b> for semiflexible pipes Øext.6	<b>PUSH IN</b> for semiflexible pipes Øext.4

CODE ① ②	Connection *	Orifice mm	KV m <sup>3</sup> /h	Differential pressure bar			Nominal power			Coil		Seal ①	Temp. Range ** °C
				Min	Max		AC Inrush	VA Holding	DC Watt	Series	Width		
					AC	DC							
E135*...15///.....	K-N-P-W-Y-Z	1.5	0.06	0	16	16	12	8	6.5	3	22	NBR=A EPDM=E	-10 +90  <+140
E135*...20///.....	K-N-P-W-Y-Z	2	0.09	0	12	10							
E135*...25///.....	K-N-P-W-Y-Z	2.5	0.14	0	8	5.5							
E135*...30///.....	K-N-P-Y	3	0.19	0	4.5	2							
E135*...40///.....	N-P-Y	4	0.35	0	2.5	1.2	15	11	5	4	30	FPM=V	-10 +130
E135*...20///.....	K-N-P-W-Y-Z	2	0.09	0	25	15							
E135*...25///.....	K-N-P-W-Y-Z	2.5	0.14	0	16	8							
E135*...30///.....	K-N-P-Y	3	0.19	0	8	4							
E135*...40///.....	N-P-Y	4	0.35	0	5	2.5							

- ① Seal Example: E135KA20///30B NBR seal SPIGGOT connection
- ② Coil Coil 24V 50/60Hz
- ③ Only for connection "W" E135W.../1/....

**REMARK:** The maximum allowable pressure PS for steam is 2,5bar (gauge pressure)

\*\* The temperature range is related to the material of the seals (NBR, EPDM, FPM), and the valves' body. Please contact us concerning the temperature range referred to the different types of connection.

COILS	Alternating Current ~50/60Hz Volt							Direct Current Volt			Electrical connection	Connectors	DESCRIPTION Class F insulation Voltage tolerance AC +15% -10% DC ± 10% Protection class IP65 with connector fitted IP00 without connector Continuous service ED100%
	12	24	48	110	220 230	240	380	12	24	48			
Series 3 Width 22 Code ②	30A	30B	30C	30D	30E	30F	30G	300	301	302	DIN 46244	PG9 code 10348000	OPTIONS Class H insulation Cable attached Special coil voltages Special coil powers
Series 4 Width 30 Code ②	40A	40B	40C	40D	40E	40F	40G	400	401	402	DIN 43650A	PG9 code 10349000	

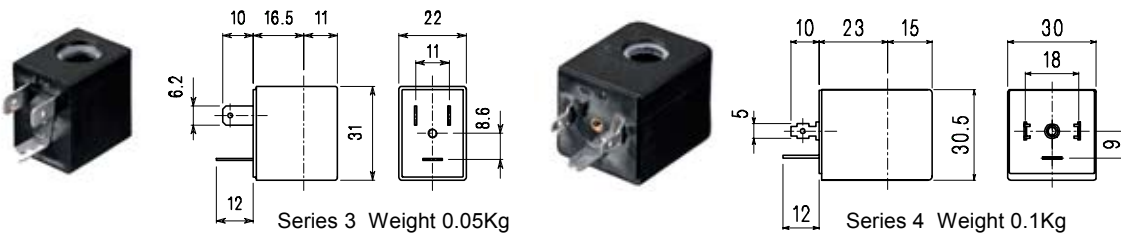

### SPARE PARTS LIST

1. Coil fixing nut
2. Coil
3. Plunger
4. Armature tube with core

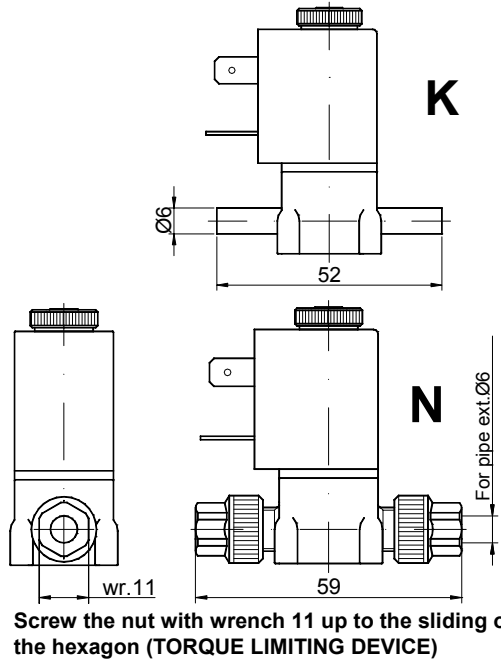
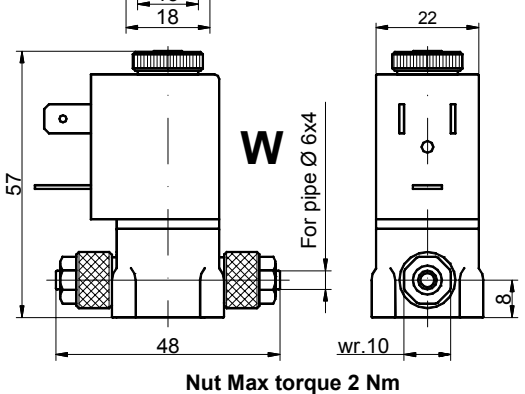
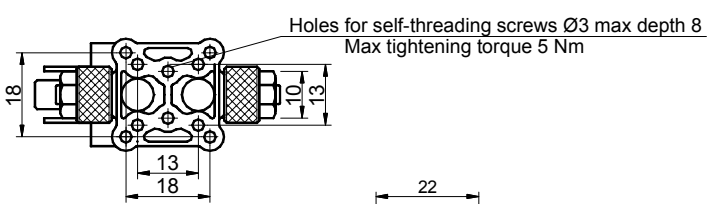
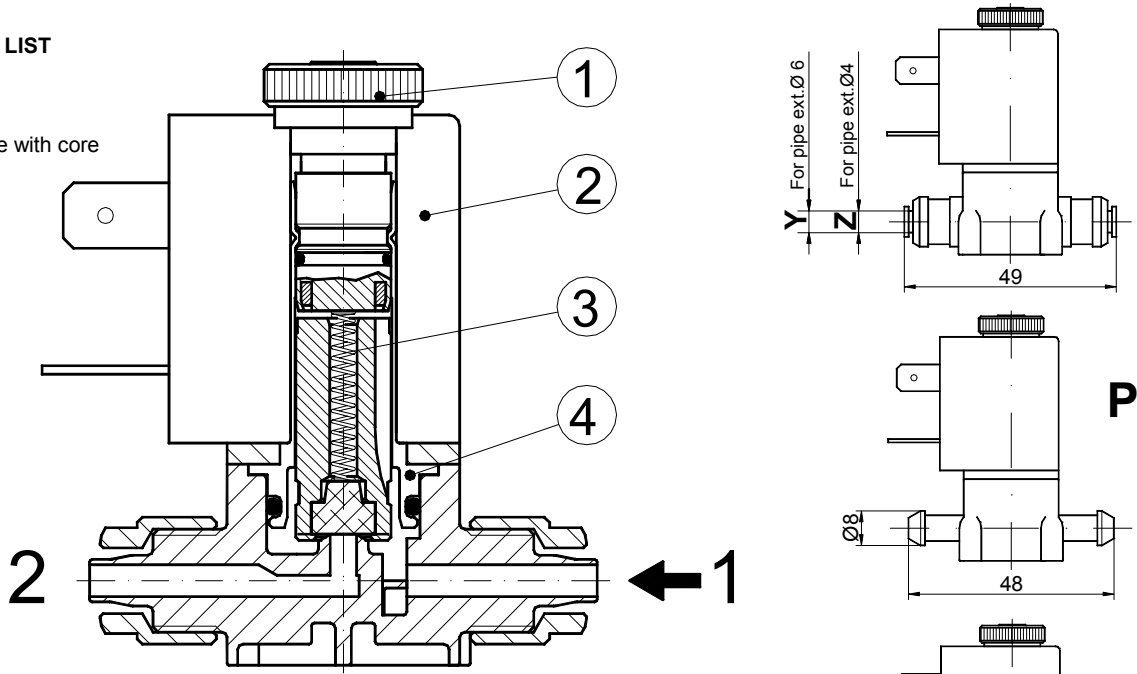

Weight with coil series 3 = 0.10 Kg  
Weight with coil series 4 = 0.15 Kg

**DESCRIPTION**

Solenoid valve 2 way normally closed direct acting with dry armature. No metal parts in contact with the media.

**CONSTRUCTION**

Body	Acetal copolymer
Armature tube	Brass
Plunger and core	Stainless steel
Springs	Stainless steel
Seal material	Silicone



**2**

**FEATURES**

Maximum allowable pressure 2 bar  
 Maximum fluid viscosity 25cSt (mm<sup>2</sup>/s)  
 Ambient temperature : with class F coil -10°C +55°C  
 with class H coil -10°C +80°C  
 Preferred mounting position with vertical coil above.

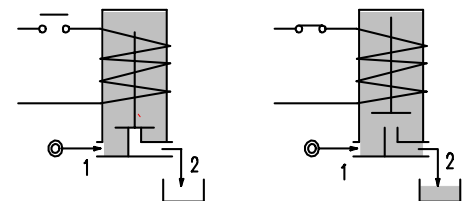
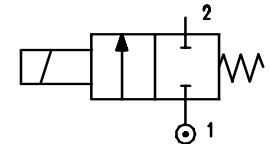

**Versions with closed vent**

CODE ②	Connection G ISO 228	Orifice mm	KV m <sup>3</sup> /h	Differential pressure bar			Nominal power			Coil		Seal	Temp. range °C
				Min	Max		AC Inrush	VA Holding	DC Watt	Series	Width		
					AC	DC							
E150PS75///.....	-	7.5	0.7	0	0.2	0.2	12	8	6.5	3	22	SILICONE=S	< +95
E150PS75/6/.....	1/4"	7.5	0.7	0	0.2	0.2							
D150PS75///.....	-	7.5	0.7	0	-	0.2							
D150PS75/5/.....	1/4"	7.5	0.7	0	-	0.2							

**Versions with open vent**

CODE ②	Connection G ISO 228	Orifice mm	KV m <sup>3</sup> /h	Differential pressure bar			Nominal power			Coil		Seal	Temp. range °C
				Min	Max		AC Inrush	VA Holding	DC Watt	Series	Width		
					AC	DC							
E150PS75/7/.....	-	7.5	0.7	0	0.2	0.2	12	8	6.5	3	22	SILICONE=S	< +95
E150PS75/1/.....	1/4"	7.5	0.7	0	0.2	0.2							
D150PS75/4/.....	-	7.5	0.7	0	-	0.2							
D150PS75/3/.....	1/4"	7.5	0.7	0	-	0.2							

② Coil

Example: E150PS75///30E Fixing by flange – Closed vent  
 Coil 220V 50/60Hz

COILS	Alternating Current ~50/60Hz Volt							Direct Current Volt			Electrical Connection	Connectors
	12	24	48	110	220 230	240	380	12	24	48		
Series 3 Width 22 Code ②	30A	30B	30C	30D	30E	30F	30G	300	301	302	DIN 46244	PG9 code 10348000

**DESCRIPTION**  
 Class F insulation  
 Voltage tolerance  
 AC +15% -10%  
 DC ± 10%  
 Protection class  
 IP65 with connector fitted  
 IP00 without connector  
 Continuous service ED100%

**OPTIONS**  
 Class H insulation  
 Cable attached  
 Special coil voltages  
 Special coil powers

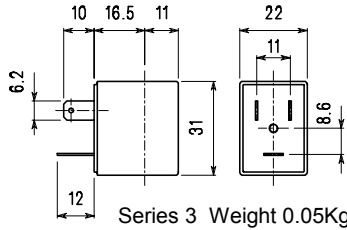

Series 3 Weight 0.05Kg

### SPARE PARTS LIST

1. Coil fixing nut
2. Coil
3. Diaphragm

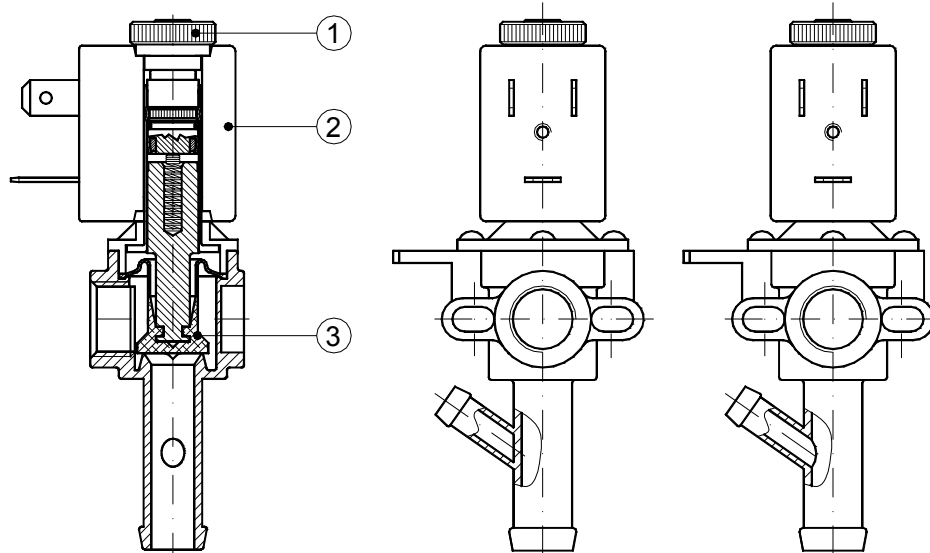

Version with closed vent

Version with open vent

### OVERALL DIMENSION

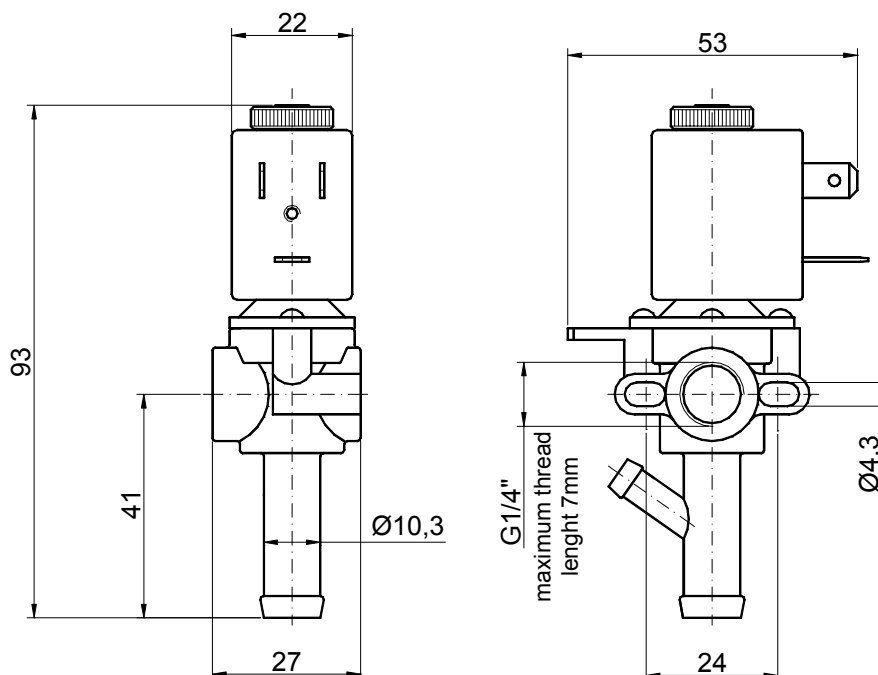

Weight = 0.1 Kg

**DESCRIPTION**

Solenoid valve 2 way normally closed direct acting with dry armature.  
No metal parts in contact with the media.

**CONSTRUCTION**

Body	Acetal copolymer
Armature tube	Brass
Plunger and core	Stainless steel
Springs	Stainless steel
Diaphragm	Silicone



**2**

**FEATURES**

Maximum allowable pressure 2 bar  
Maximum fluid viscosity 25cSt (mm<sup>2</sup>/s)  
Ambient temperature : with class F coil -10°C +55°C  
with class H coil -10°C +80°C  
Preferred mounting position with vertical coil above

**OPTIONS :** Nickel plated armature tube  
For connection accessories see section 8

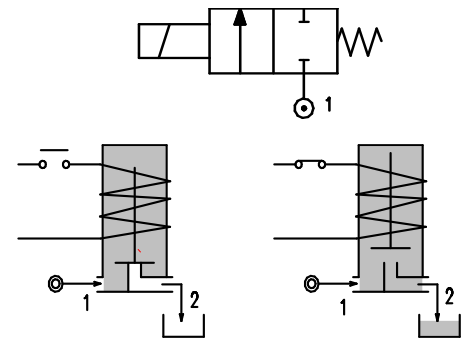

CONNECTION				
E151BBS70	E151PPS60	E151PPS40	E151BPS60	E151BPS40
G1/4"	Hosetail DN6	Hosetail DN4	G1/4" - Hosetail DN6	G1/4" - Hosetail DN4

**OTHER CONFIGURATIONS AVAILABLE ON REQUEST**

CODE ②	Connection	Orifice mm	KV m <sup>3</sup> /h	Differential pressure bar			Nominal power			Coil		Diaphragm	Temp. range °C
				Min	Max		AC Inrush	VA Holding	DC Watt	Series	Width		
					AC	DC							
E151BBS70///...	G1/4"	7	0.83	0	0.6	0.3	12	8	6.5	3	22	SILICONE=S	< +95
E151PPS60///...	Hosetail DN6	6	0.63	0	0.6	0.3							
E151PPS40///...	Hosetail DN4	4	0.34	0	0.6	0.3							
E151BPS60///...	G1/4" - Hosetail DN6	6	0.63	0	0.6	0.3							
E151BPS40///...	G1/4" - Hosetail DN4	4	0.34	0	0.6	0.3							

② Coil

Example: E151BPS60///30E G1/4" inlet , Hosetail DN6 outlet, silicone seal  
Coil 220V 50/60Hz

**FOR HIGHER DIFFERENTIAL PRESSURE CONTACT THE MANUFACTURER**

COILS	Alternating Current ~50/60Hz Volt							Direct Current Volt			Electrical connection	Connectors
	12	24	48	110	220 230	240	380	12	24	48		
Series 3 Width 22 Code ②	30A	30B	30C	30D	30E	30F	30G	300	301	302	DIN 46244	PG9 code 10348000

**DESCRIPTION**  
 Class F insulation  
 Voltage tolerance  
 AC +15% -10%  
 DC ± 10%  
 Protection class  
 IP65 with connector fitted  
 IP00 without connector  
 Continuous service ED100%

**OPTIONS**  
 Class H insulation  
 Cable attached  
 Special coil voltage  
 Special coil powers

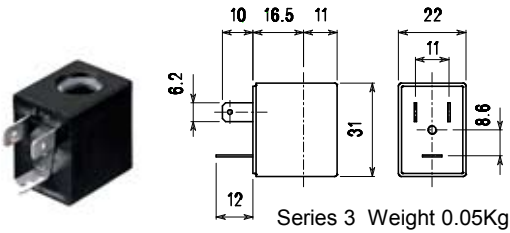

### SPARE PARTS LIST

1. Coil fixing clip
2. Coil
3. Diaphragm

FOR CONNECTION ACCESSORIES SEE SECTION 8

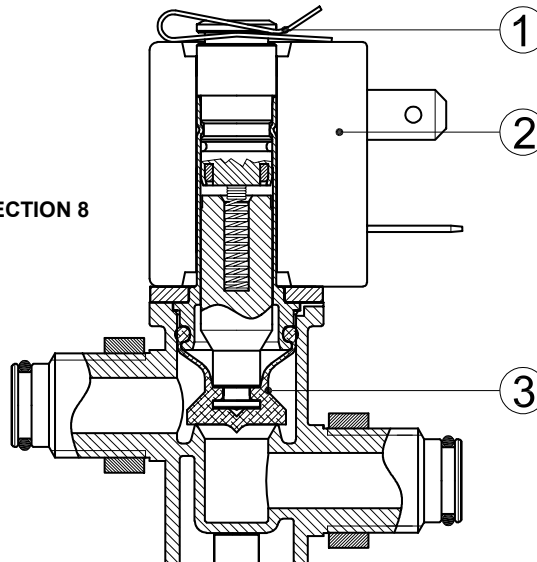

### OVERALL DIMENSION

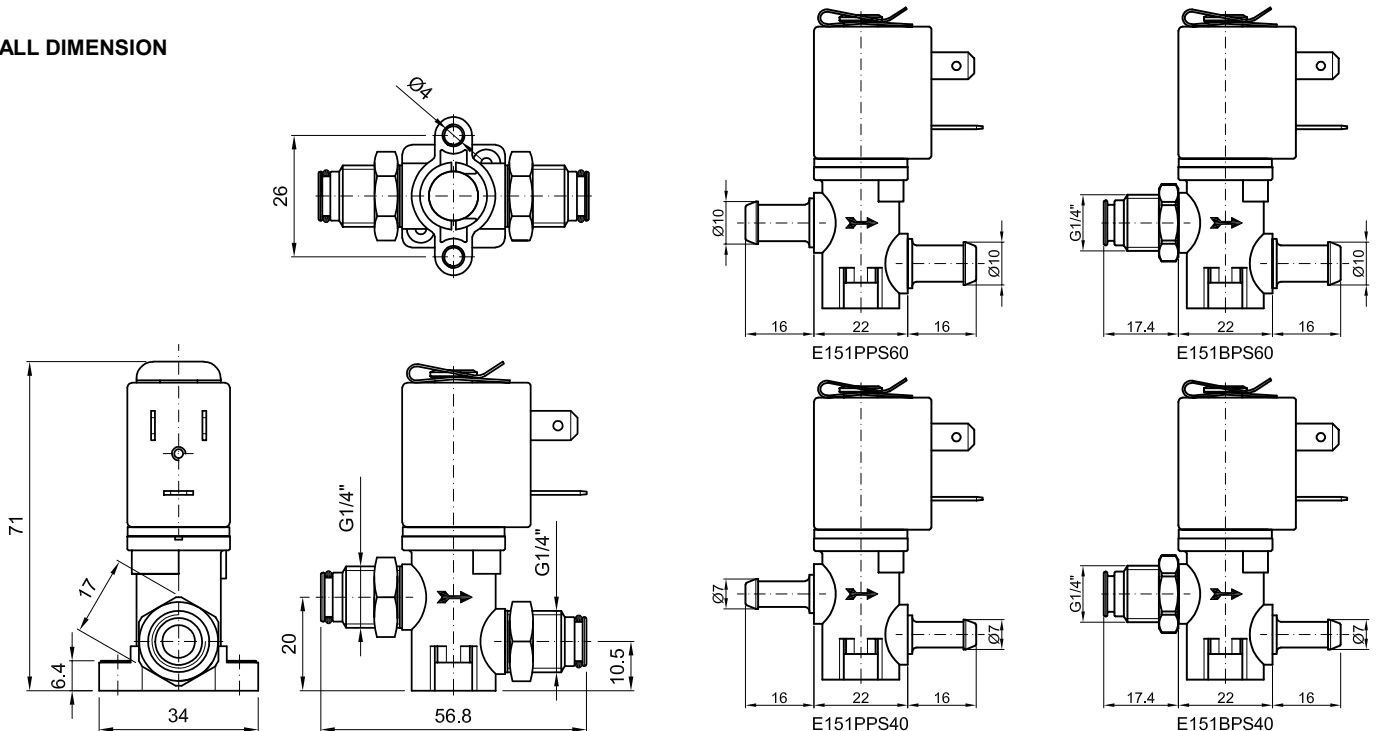



### DESCRIPTIONS

Solenoid valve 2 way normally closed  
 direct acting with dry armature.  
 No metal parts in contact with the media.

### CONSTRUCTION

Body	Acetal copolymer
Armature tube	Stainless steel
Plunger and core	Stainless steel
Springs	Stainless steel
Seal material	Silicone



2

### FEATURES

Maximum allowable pressure 1.5 bar  
 Maximum fluid viscosity 25cSt (mm<sup>2</sup>/s)  
 Ambient temperature : with class F coil -10°C +55°C  
                                   with class H coil -10°C +80°C  
 Mounting position with vertical coil above

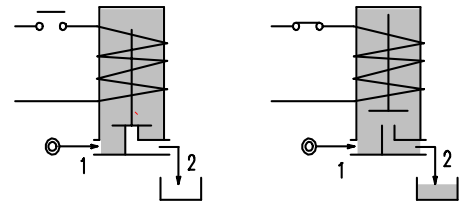
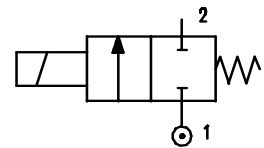

CODE ②	Connection G ISO 228	Orifice mm	KV m <sup>3</sup> /h	Differential pressure bar		Nominal power			Coil		Seal	Temp. range °C
				Inlet	Outlet	AC Inrush	VA Holding	DC Watt	Series	Width		
<b>Version with closed vent</b>												
E160SS10/2/.....	1/2"	10	1.7	0.5	0.1	20	15	10	2	30	SILICONE=S	< +95
<b>Version with open vent</b>												
E160SS10/3/.....	1/2"	10	1.7	0.5	0.1	20	15	10	2	30		

② Coil

Example: E160SS10/2/20E Closed vent - Coil 220V 50/60Hz

COILS	Alternating Current ~50/60Hz Volt							Direct Current Volt			Electrical connection	Connectors
	12	24	48	110	220 230	240	380	12	24	48		
Series 2 Width 30 Code ②	20A	20B	20C	20D	20E	20F	20G	200	201	202	DIN 43650A	PG9 code 10349000

**DESCRIPTION**  
 Class F insulation  
 Voltage tolerance  
 AC +15% -10%  
 DC ± 10%  
 Protection class  
 IP65 with connector fitted  
 IP00 without connector  
 Continuous service ED100%

**OPTIONS**  
 Class H insulation  
 Cable attached  
 Special coil voltages  
 Special coil powers

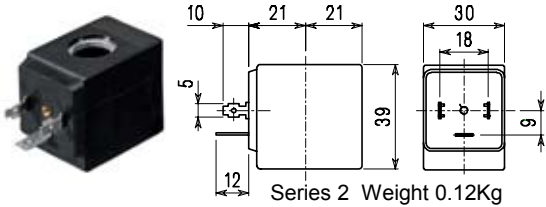

### SPARE PARTS LIST

1. Coil fixing nut
2. Coil
3. Diaphragm

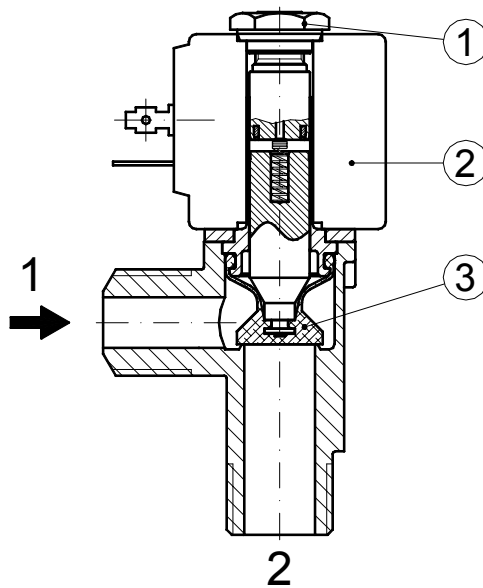

**E160SS10/2/...**

Version with closed vent

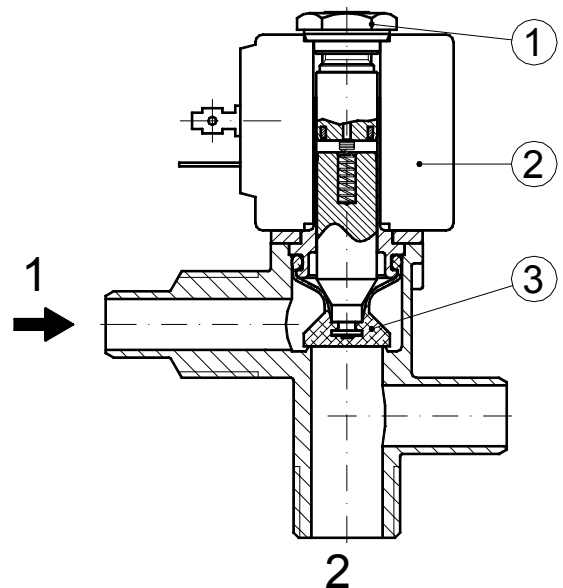

**E160SS10/3/...**

Version with open vent

### OVERALL DIMENSION

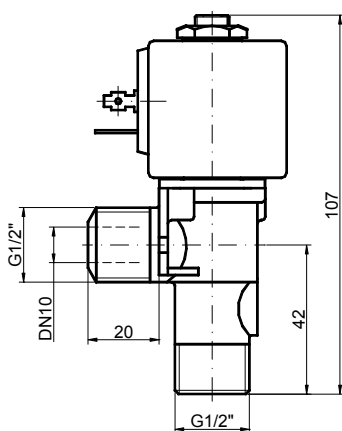

**E160SS10/2/...**

Weight 0.22 Kg

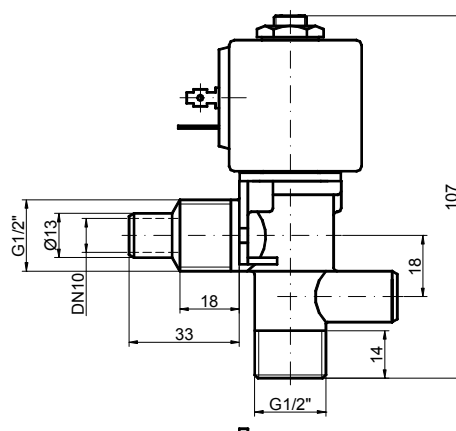

**E160SS10/3/...**

Weight 0.24 Kg

## DESCRIPTION

Solenoid valve 2 way normally closed  
 direct acting with dry armature and  
 hosetails for flexible pipes.  
 No metal parts in contact with the media.

## CONSTRUCTION

Body	Acetal copolymer
Armature tube	Stainless steel
Plunger and core	Stainless steel
Springs	Stainless steel
Seal material	Silicone



**2**

## FEATURES

Maximum allowable pressure 2 bar  
 Maximum fluid viscosity 25cSt (mm<sup>2</sup>/s)  
 Ambient temperature : with class F coil -10° +55°C  
 with class H coil -10° +80°C  
 Mounting position with vertical coil above

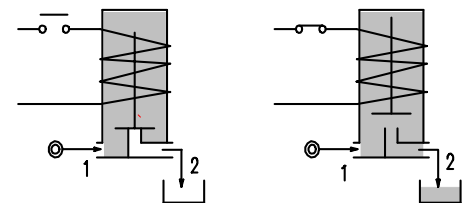
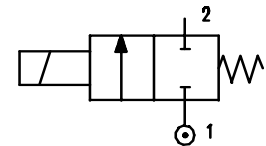

CODE ②	Connection mm	KV m³/h	Differential pressure bar			Nominal power			Coil		Seal	Temp. range °C
			Min	Max		AC Inrush	VA Holding	DC Watt	Series	Width		
				AC	DC							
E161PS8///.....	8	1.1	0	0.15	0.15	20	15	10	2	30	SILICONE=S	< +95
E161PS8/1/.....	8	1.1	0	0.5	0.5	40	30	27	5	36		

## For use with VACUUM – feeds from 2 to 1

CODE ②	Connection mm	KV m³/h	Differential pressure bar			Nominal power			Coil		Seal	Temp. range °C
			Min	Max		AC Inrush	VA Holding	DC Watt	Series	Width		
				AC	DC							
E161PS8/V/.....	8	1.1	0	-0.9	-0.7	20	15	10	2	30	SILICONE=S	< +95
E161PS8/V/.....	8	1.1	0	-0.9	-0.9	40	30	27	5	36		

② Coil

Example: E161PS8///20E  
 Coil 220V 50/60Hz

COILS	Alternating Current ~50/60Hz Volt							Direct Current Volt			Electrical connection	Connectors
	12	24	48	110	220 230	240	380	12	24	48		
Series 2 Width 30 Code ②	20A	20B	20C	20D	20E	20F	20G	200	201	202	DIN 43650A	PG9 code 10349000
Series 5 Width 36 Code ②	52A	52B	52C	52D	52E	52F	52G	521	521	522	DIN 43650A	PG11 code 10349001

**DESCRIPTION**  
 Insulation class  
 Series 2=F Series 5=H  
 Voltage tolerance  
 AC +15% -10%  
 DC ± 10%  
 Protection class  
 IP65 with connector fitted  
 IP00 without connector  
 Continuous service ED100%

**OPTIONS**  
 Class H insulation (series 2)  
 Cable attached  
 Special coil voltages  
 Special coil powers

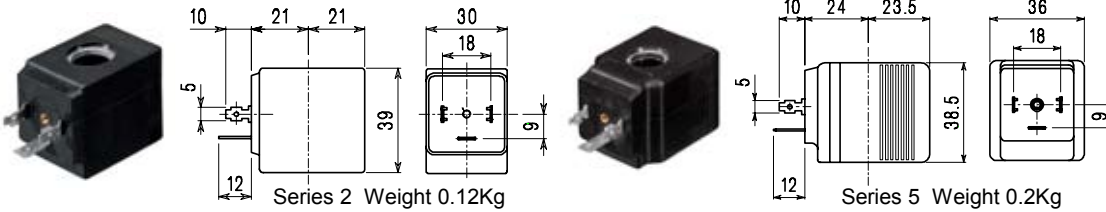

### SPARE PARTS LIST

1. Coil fixing nut
2. Coil
3. Diaphragm

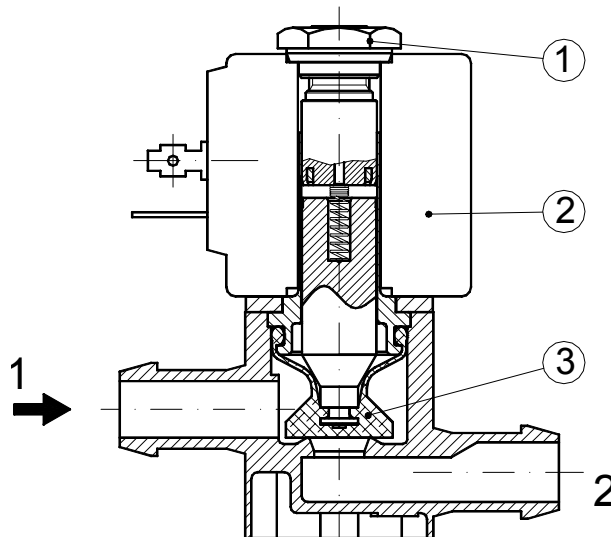

### OVERALL DIMENSION

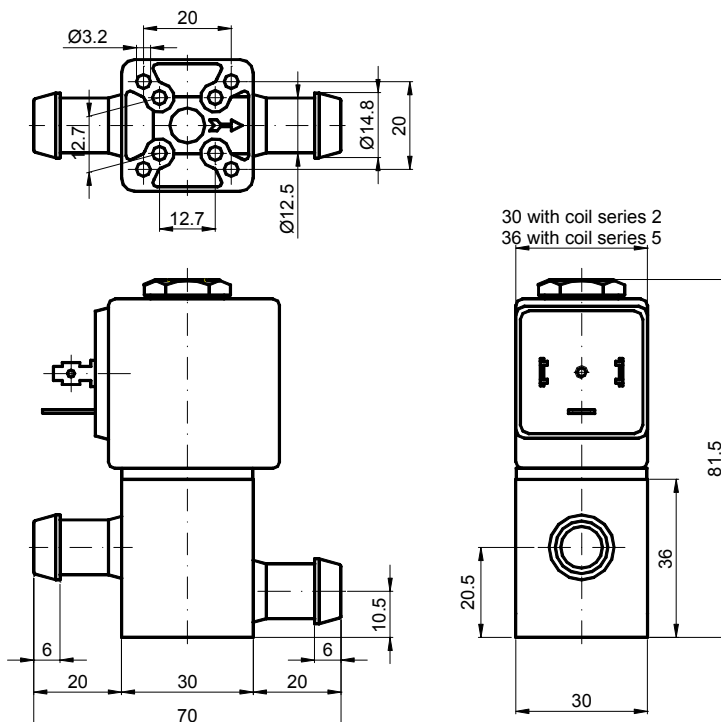

Weight with coil series 2 = 0.23 Kg  
 Weight with coil series 5 = 0.31 Kg

**DESCRIPTION**

Solenoid valve in-line 2 way normally open direct acting poppet type

**CONSTRUCTION**

Body	Brass
Armature tube	Stainless steel
Plunger and core	Stainless steel
Springs	Stainless steel
Seal material	NBR
	FPM
	EPDM



**2**

**FEATURES**

Maximum allowable pressure 50 bar  
 Maximum fluid viscosity 25cSt (mm<sup>2</sup>/s)  
 Ambient temperature : with class F coil -10°C +55°C  
 with class H coil -10°C +80°C  
 Universal mounting position

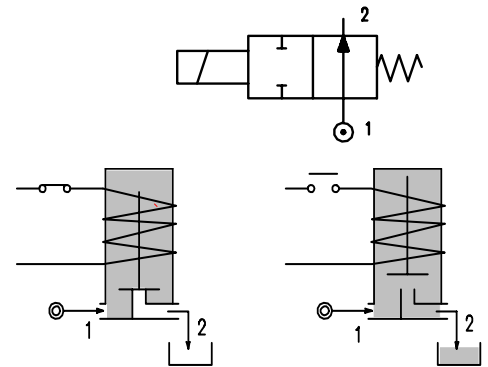

**OPTIONS :** Electroless nickel plating

CODE ① ②	Connection G ISO 228	Orifice mm	KV m <sup>3</sup> /h	Differential pressure bar			Nominal power			Coil		Seal ①	Temp. range °C
				Min	Max		AC Inrush	VA Holding	DC Watt	Series	Width		
					AC	DC							
E203A.....20///.....	1/8"	2	0.1	0	16	16	20	15	10	2	30	NBR=B	-10 +90
E203A.....25///.....	1/8"	2.5	0.14	0	13	13						EPDM=E	<+140
E203A.....29///.....	1/8"	2.9	0.17	0	10	10						FPM=V	-10 +130

- ① Seal
- ② Coil

Example: E203AV25///20E FPM seal  
 Coil 220V 50/60Hz

COILS	Alternating Current ~50/60Hz Volt							Direct Current Volt			Electrical connection	Connectors
	12	24	48	110	220 230	240	380	12	24	48		
Series 2 Width 30 Code ②	20A	20B	20C	20D	20E	20F	20G	200	201	202	DIN 43650A	PG9 code 10349000

**DESCRIPTION**  
 Class F insulation  
 Voltage tolerance  
 AC +15% -10%  
 DC ± 10%  
 Protection class  
 IP65 with connector fitted  
 IP00 without connector  
 Continuous service ED100%

**OPTIONS**  
 Class H insulation  
 Cable attached  
 Special coil voltages  
 Special coil powers

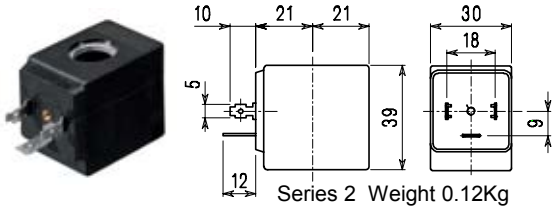

### SPARE PARTS LIST

1. Coil fixing nut
2. Coil
3. Plunger
4. Armature tube with core

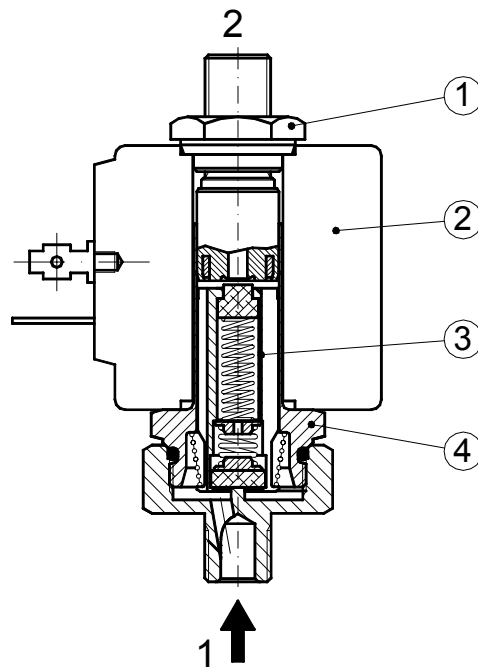

### OVERALL DIMENSION

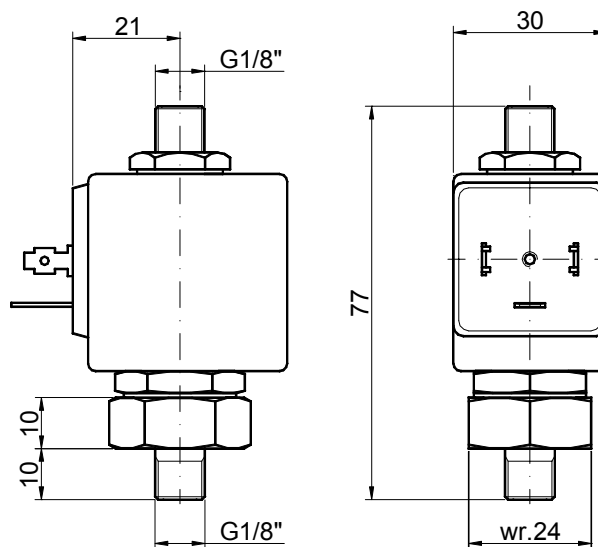

Weight = 0.22 Kg

**DESCRIPTION**

Solenoid valve in-line 2 way normally open direct acting poppet type.

**CONSTRUCTION**

Body	Brass
Armature tube	Brass
Plunger and core	Stainless steel
Springs	Stainless steel
Seal material	NBR
	FPM
	EPDM



**2**

**FEATURES**

Maximum allowable pressure : max working pressure +10%  
 Maximum fluid viscosity 25cSt (mm<sup>2</sup>/s)  
 Ambient temperature : with class F coil -10°C +55°C  
 with class H coil -10°C +80°C  
 Universal mounting position

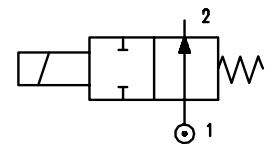

**OPTIONS :** Armature tube in stainless steel  
 Electroless nickel plating  
 Explosion proof coil according to ATEX - EExmII Series 7  
 User port with hosetail connection

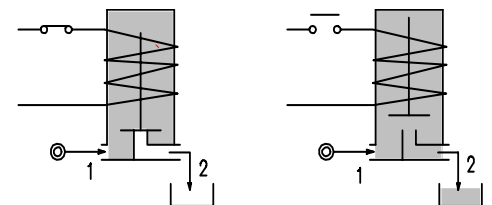

CODE ① ②	Connection G ISO 228	Orifice mm	KV m <sup>3</sup> /h	Differential pressure bar			Nominal power			Coil		Seal ①	Temp. range °C
				Min	Max		AC Inrush	VA Holding	DC Watt	Series	Width		
					AC	DC							
<b>User port with M5 connection</b>													
E204A.....15///.....	1/8"	1.5	0.06	0	16	16	12	8	6.5	3	22	NBR=B	-10 +90
E204A.....17///.....		1.7	0.08	0	12	12							
<b>User port with hosetail connection</b>													
E204A.....15/1/.....	1/8"	1.5	0.06	0	16	16	12	8	6.5	3	22	EPDM=E	<+140
E204A.....17/1/.....		1.7	0.08	0	12	12							
<b>User port with hosetail connection and relief valve</b>													
E204A.....15/3/.....	1/8"	1.5	0.06	0	16	16	12	8	6.5	3	22	FPM=V	-10 +130
E204A.....17/3/.....		1.7	0.08	0	12	12							

- ① Seal
- ② Coil

Example: E204AB17///301 NBR seal  
 Coil 24V DC

COILS	Alternating Current ~50/60Hz Volt							Direct Current Volt			Electrical connection	Connectors
	12	24	48	110	220 230	240	380	12	24	48		
Series 3 Width 22 Code ②	30A	30B	30C	30D	30E	30F	30G	300	301	302	DIN 46244	PG9 code 10348000

**DESCRIPTION**  
 Class F insulation  
 Voltage tolerance  
 AC +15% -10%  
 DC ± 10%  
 Protection class  
 IP65 with connector fitted  
 IP00 without connector  
 Continuous service ED100%

**OPTIONS**  
 Class H insulation  
 Cable attached  
 Special coil voltages  
 Special coil powers

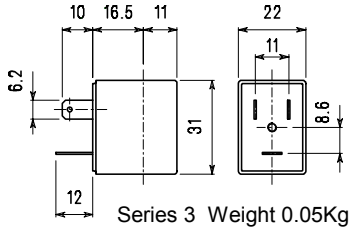

### SPARE PARTS LIST

1. Coil fixing nut
2. Coil
3. Plunger
4. Armature tube with core

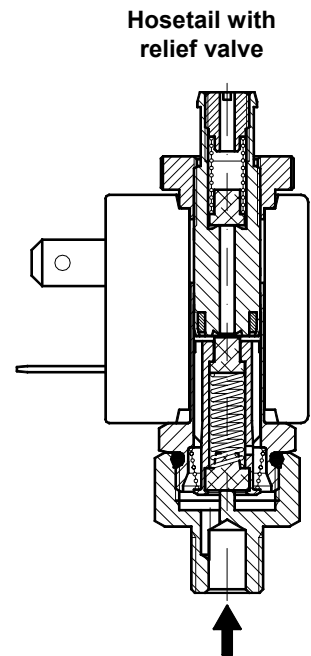
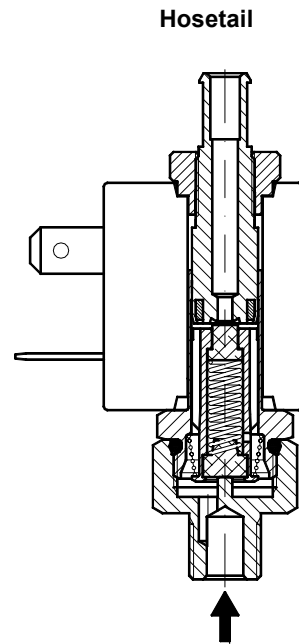
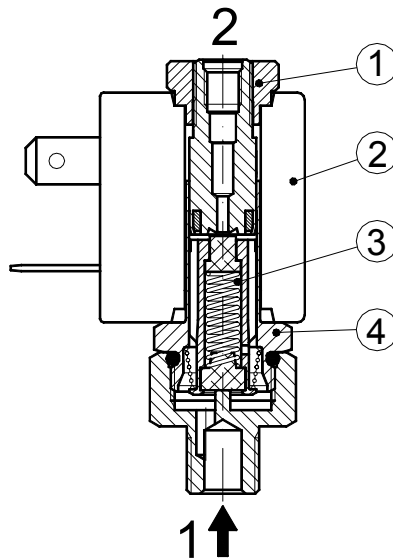

### OVERALL DIMENSION

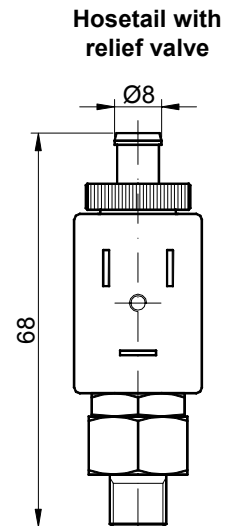
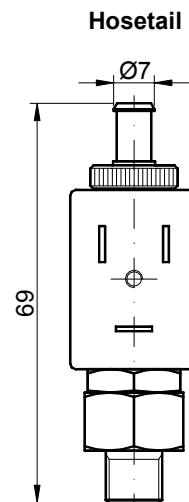
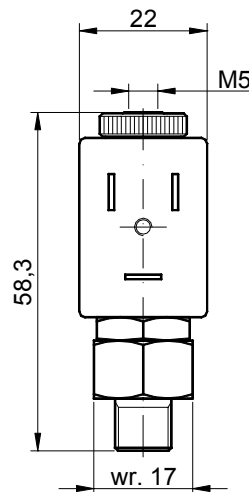
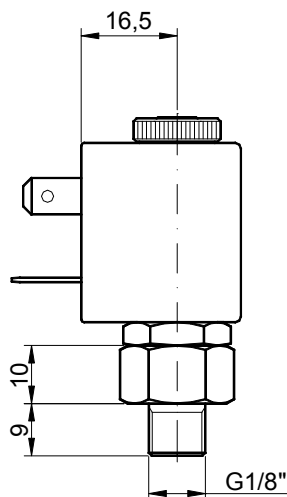

Weight = 0.10 Kg



**DESCRIPTION**

Solenoid valve 2 way normally open  
open direct acting poppet type.

**CONSTRUCTION**

Body	Brass
Armature tube	Brass
Plunger and core	Stainless steel
Springs	Stainless steel
Seal material	NBR
	FPM
	EPDM



**2**

**FEATURES**

- Maximum allowable pressure 50 bar \*
- Maximum fluid viscosity 25cSt (mm<sup>2</sup>/s)
- Ambient temperature : with class F coil -10°C +55°C  
with class H coil -10°C +80°C
- Universal mounting position

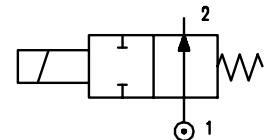

- OPTIONS :** Stainless steel armature tube  
Electroless nickel plating  
Explosion proof coil according to ATEX - EExmII Series 7

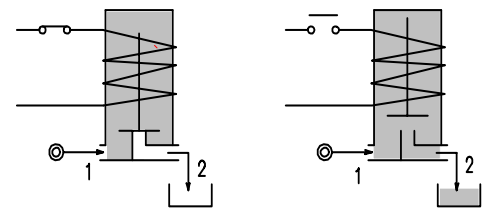

CODE ① ②	Connection G ISO 228	Orifice mm	KV M <sup>3</sup> /h	Differential pressure bar			Nominal power			Coil		Seal ①	Temp. range °C
				Min	Max		AC Inrush	VA Holding	DC Watt	Series	Width		
					AC	DC							
E205A.....12///.....	1/8"	1.2	0.04	0	19	19	12	8	6.5	3	22	NBR=B	-10 +90
E205A.....15///.....		1.5	0.06	0	14	14						EPDM=E	<+140
E205A.....20///.....		2	0.09	0	8	8						FPM=V	-10 +130
E205A.....25///.....		2.5	0.14	0	4.5	4.5							
E205A.....31///.....		3.1	0.19	0	2.5	2.5							

- ① Seal Example: E205AB20///30B NBR seal
- ② Coil Coil 24V 50/60Hz

\* REMARK: The maximum allowable pressure PS for steam is 2,5bar (gauge pressure)

COILS	Alternating Current ~50/60Hz Volt							Direct Current Volt			Electrical connection	Connectors
	12	24	48	110	220 230	240	380	12	24	48		
Series 3 Width 22 Code ②	30A	30B	30C	30D	30E	30F	30G	300	301	302	DIN 46244	PG9 code 10348000

**DESCRIPTION**  
 Class F insulation  
 Voltage tolerance  
 AC +15% -10%  
 DC ± 10%  
 Protection class  
 IP65 with connector fitted  
 IP00 without connector  
 Continuous service ED100%

**OPTIONS**  
 Class H insulation  
 Cable attached  
 Special coil voltages  
 Special coil powers

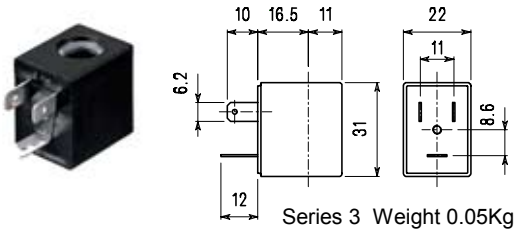

### SPARE PARTS LIST

1. Coil fixing nut
2. Coil
3. Seal assembly
4. Armature tube with core

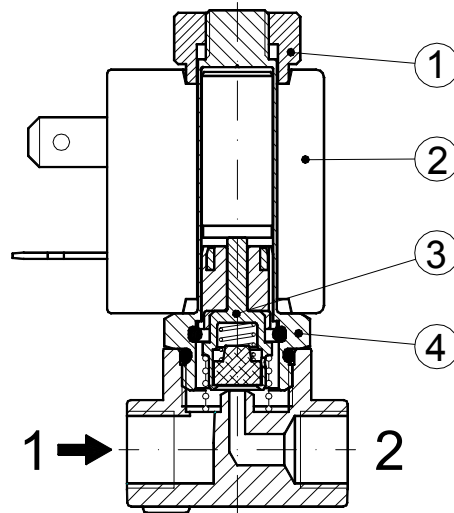

### OVERALL DIMENSION

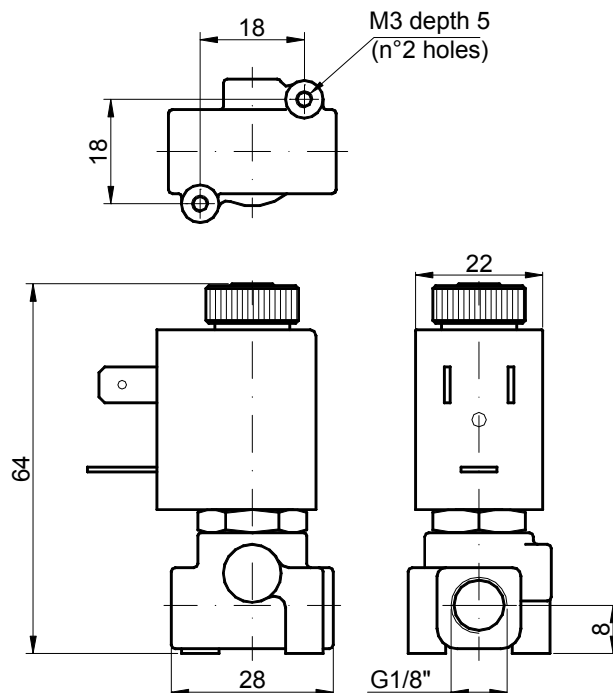

Weight = 0.13 Kg

**DESCRIPTION**

Solenoid valve 2 way normally open  
direct acting poppet type

**CONSTRUCTION**

Body	Brass
Armature tube	Brass
Plunger and core	Stainless steel
Springs	Stainless steel
Seal material	NBR FPM EPDM



**2**

**FEATURES**

Maximum allowable pressure 50 bar \*  
Maximum fluid viscosity 25cSt (mm<sup>2</sup>/s)  
Ambient temperature : with coil class F -10°C +55°C  
with coil class H -10°C +80°C  
Universal mounting position

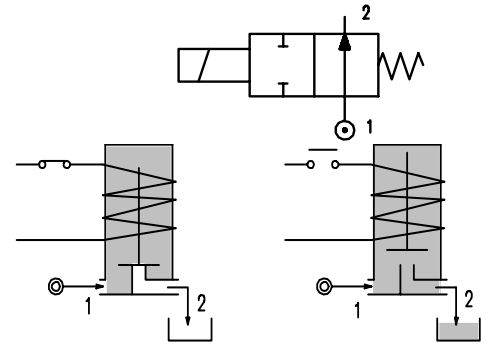

**OPTIONS :** Electroless nickel plating  
Stainless steel armature tube

CODE ① ②	Connection G ISO 228	Orifice mm	KV m <sup>3</sup> /h	Differential pressure bar			Nominal power			Coil		Seal ①	Temp. range °C
				Min	Max		AC Inrush	VA Holding	DC Watt	Series	Width		
					AC	DC							
E206A.....15///.....	1/8"	1.5	0.07	0	23	-	20	15	-	2	30	NBR=B	-10 +90
E206A.....20///.....		2	0.1	0	17	-							
E206A.....25///.....		2.5	0.15	0	12	-							
E206A.....35///.....		3.5	0.32	0	7	-							
E206A.....15///.....	1/8"	1.5	0.07	0	23	23	40	30	27	5	36	EPDM=E	<+140
E206A.....20///.....		2	0.1	0	17	17							
E206A.....25///.....		2.5	0.15	0	12	12							
E206A.....35///.....		3.5	0.32	0	7	7							
D206A.....15/3/.....	1/8"	1.5	0.07	0	-	18	-	-	10	2	30	FPM=V	-10 +130
D206A.....20/3/.....		2	0.1	0	-	11							
D206A.....25/3/.....		2.5	0.15	0	-	7							
D206A.....35/3/.....		3.5	0.32	0	-	4							

① Seal Example: E206AB35///20E NBR seal  
② Coil Coil 220V 50/60Hz

\* REMARK: The maximum allowable pressure PS for steam is 2,5bar (gauge pressure)

COILS	Alternating Current ~50/60Hz Volt							Direct Current Volt			Electrical connection	Connectors
	12	24	48	110	220 230	240	380	12	24	48		
Series 2 Width 30 Code ②	20A	20B	20C	20D	20E	20F	20G	200	201	202	DIN 43650A	PG9 code 10349000
Series 5 Width 36 Code ②	52A	52B	52C	52D	52E	52F	52G	520	521	522	DIN 43650A	PG11 code 10349001

**DESCRIPTION**  
 Insulation class  
 Series 2=F Series 5=H  
 Voltage tolerance  
 AC +15% -10%  
 DC ± 10%  
 Protection class  
 IP65 with connector fitted  
 IP00 without connector  
 Continuous service ED100%

**OPTIONS**  
 Class H insulation (series 2)  
 Cable attached  
 Special coil voltages  
 Special coil powers

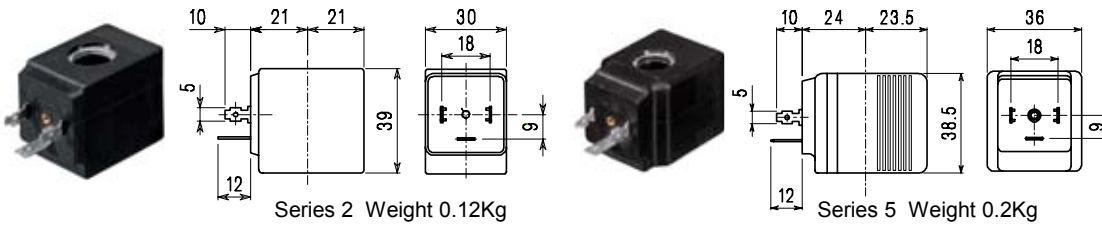

### SPARE PARTS

1. Coil fixing nut
2. Coil
3. Seal assembly
4. Armature tube

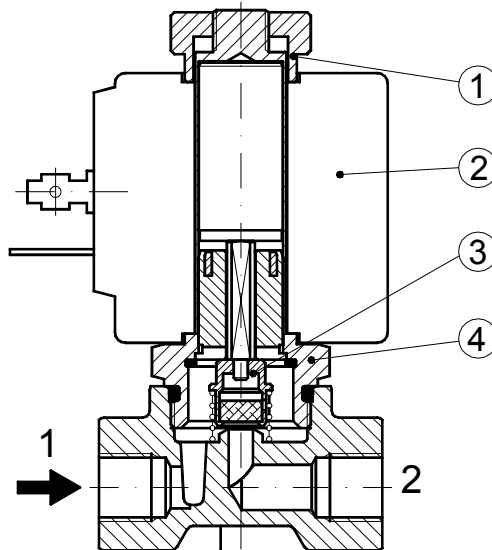

### OVERALL DIMENSION

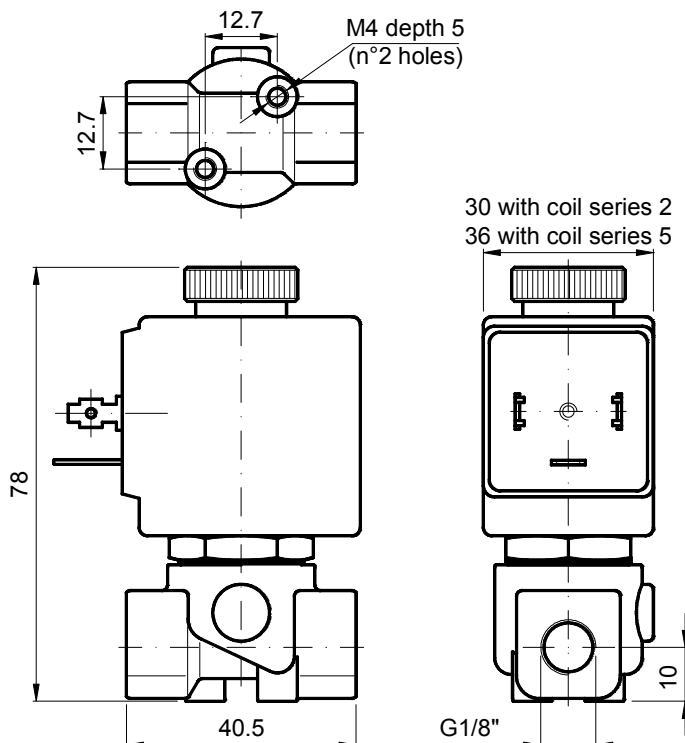

Weight with coil series 2 = 0.30 Kg  
 Weight with coil series 5 = 0.38 Kg

### DESCRIPTION

Solenoid valve 2 way normally open  
direct acting poppet type

### CONSTRUCTION

Body	Brass
Armature tube	Brass
Plunger and core	Stainless steel
Springs	Stainless steel
Seal material	NBR
	FPM
	EPDM



2

### FEATURES

Maximum allowable pressure 50 bar \*  
Maximum fluid viscosity 25cSt (mm<sup>2</sup>/s)  
Ambient temperature : with coil class F -10°C +55°C  
with coil class H -10°C +80°C  
Universal mounting position

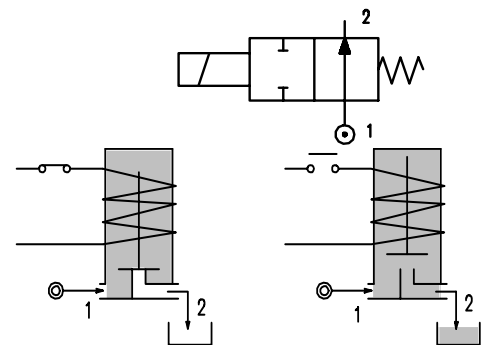

**OPTIONS :** Electroless nickel plating  
Stainless steel armature tube

CODE ① ②	Connection G ISO 228	Orifice mm	KV m <sup>3</sup> /h	Differential pressure bar			Nominal power			Coil		Seal ①	Temp. range °C
				Min	Max		AC Inrush	VA Holding	DC Watt	Series	Width		
					AC	DC							
E206B.....15///.....	1/4"	1.5	0.07	0	23	-	20	15	-	2	30	NBR=B EPDM=E FPM=V	-10 +90 <+140 -10 +130
E206B.....20///.....		2	0.1	0	17	-							
E206B.....25///.....		2.5	0.15	0	12	-							
E206B.....35///.....		3.5	0.32	0	7	-							
E206B.....45///.....		4.5	0.41	0	4.5	-							
E206B.....52///.....		5.2	0.47	0	3	-							
E206B.....15///.....	1/4"	1.5	0.07	0	23	23	40	30	27	5	36		
E206B.....20///.....		2	0.1	0	17	17							
E206B.....25///.....		2.5	0.15	0	12	12							
E206B.....35///.....		3.5	0.32	0	7	7							
E206B.....45///.....		4.5	0.41	0	4.5	4.5							
E206B.....52///.....		5.2	0.47	0	3	3							
E206B.....64///.....	6.4	0.64	0	3.5	3.5								
D206B.....15/3/.....	1/4"	1.5	0.07	0	-	18	-	-	10	2	30		
D206B.....20/3/.....		2	0.1	0	-	11							
D206B.....25/3/.....		2.5	0.15	0	-	7							
D206B.....35/3/.....		3.5	0.32	0	-	4							
D206B.....45/3/.....		4.5	0.41	0	-	3							
D206B.....52/3/.....		5.2	0.47	0	-	2.2							

① Seal Example: E206BB35///20E NBR seal  
② Coil Coil 220V 50/60Hz

\* REMARK: The maximum allowable pressure PS for steam is 2,5bar (gauge pressure)

COILS	Alternating Current ~50/60Hz Volt							Direct Current Volt			Electrical connection	Connectors
	12	24	48	110	220 230	240	380	12	24	48		
Series 2 Width 30 Code ②	20A	20B	20C	20D	20E	20F	20G	200	201	202	DIN 43650A	PG9 code 10349000
Series 5 Width 36 Code ②	52A	52B	52C	52D	52E	52F	52G	520	521	522	DIN 43650A	PG11 code 10349001

**DESCRIPTION**  
 Insulation class  
 Series 2=F Series 5=H  
 Voltage tolerance  
 AC +15% -10%  
 DC ± 10%  
 Protection class  
 IP65 with connector fitted  
 IP00 without connector  
 Continuous service ED100%

**OPTIONS**  
 Class H insulation (series 2)  
 Cable attached  
 Special coil voltages  
 Special coil powers

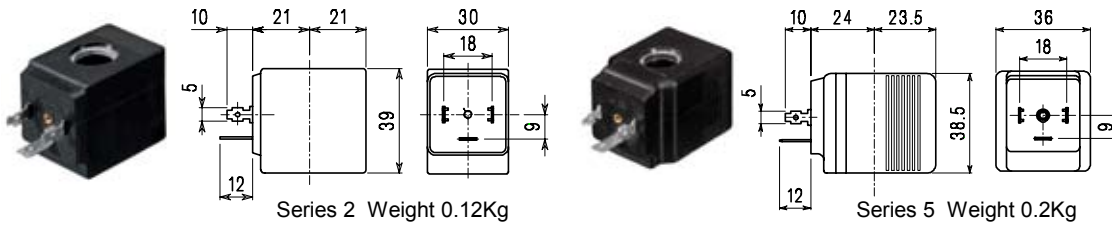

### SPARE PARTS

1. Coil fixing nut
2. Coil
3. Seal assembly
4. Armature tube

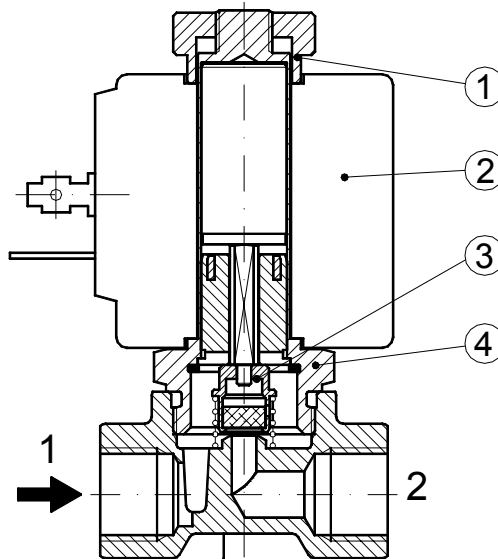

### OVERALL DIMENSION

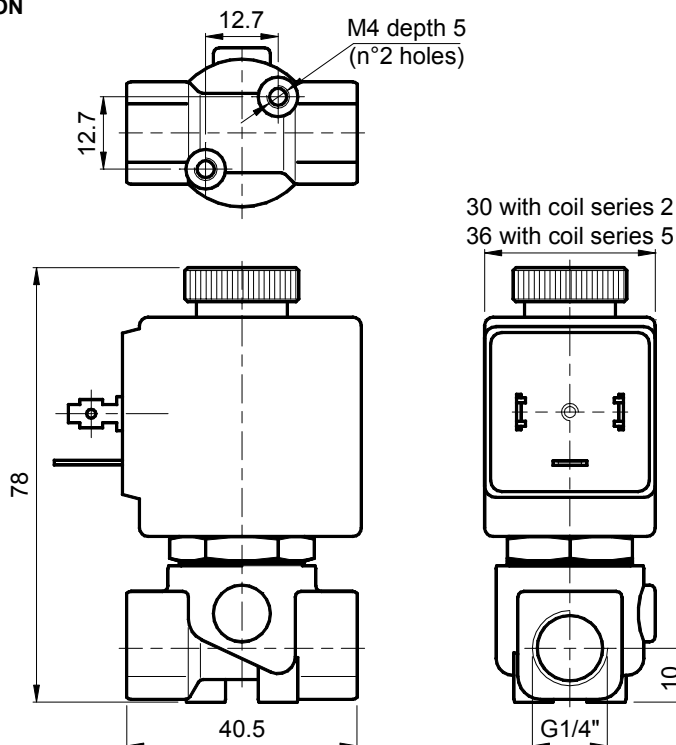

Weight with coil series 2 = 0.30 Kg  
 Weight with coil series 5 = 0.38 Kg

**DESCRIPTION**

Solenoid valve 2 way normally open  
direct acting poppet type

**CONSTRUCTION**

Body	Brass
Armature tube	Brass
Plunger and core	Stainless steel
Springs	Stainless steel
Seal material	NBR
	FPM
	EPDM



**2**

**FEATURES**

Maximum allowable pressure 50 bar \*  
Maximum fluid viscosity 25cSt (mm<sup>2</sup>/s)  
Ambient temperature : with coil class F -10°C +55°C  
with coil class H -10°C +80°C  
Universal mounting position

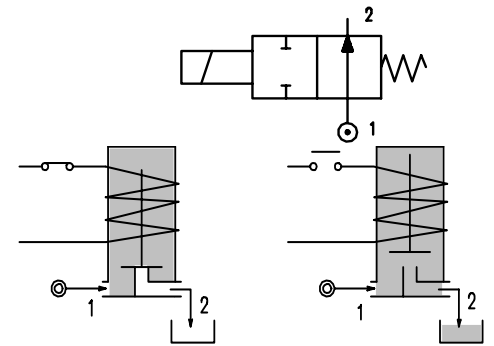

**OPTIONS :** Electroless nickel plating  
Stainless steel armature tube

CODE ① ②	Connection G ISO 228	Orifice mm	KV m <sup>3</sup> /h	Differential pressure bar			Nominal power			Coil		Seal ①	Temp. Range °C
				Min	Max		AC Inrush	VA Holding	DC Watt	Series	Width		
					AC	DC							
E206C.....30///.....	3/8"	3	0.25	0	9	-	20	15	-	2	30	NBR=B	-10 +90
E206C.....35///.....		3.5	0.32	0	7	-							
E206C.....40///.....		4	0.36	0	5.5	-							
E206C.....45///.....		4.5	0.41	0	4.5	-							
E206C.....52///.....		5.2	0.47	0	3	-							
E206C.....30///.....	3/8"	3	0.25	0	9	9	40	30	27	5	36	EPDM=E	<+140
E206C.....35///.....		3.5	0.32	0	7	7							
E206C.....40///.....		4	0.36	0	5.5	5.5							
E206C.....45///.....		4.5	0.41	0	4.5	4.5							
E206C.....52///.....		5.2	0.47	0	3	3							
E206C.....64///.....		6.4	0.64	0	3.5	3.5							
D206C.....30/3/.....	3/8"	3	0.25	0	-	6.5	-	-	10	2	30	FPM=V	-10 +130
D206C.....35/3/.....		3.5	0.32	0	-	4							
D206C.....40/3/.....		4	0.36	0	-	3.5							
D206C.....45/3/.....		4.5	0.41	0	-	3							
D206C.....52/3/.....		5.2	0.47	0	-	2.2							

① Seal Example: E206CB45///20E NBR seal  
② Coil Coil 220V 50/60Hz

\* REMARK: The maximum allowable pressure PS for steam is 2,5bar (gauge pressure)

COILS	Alternating Current ~50/60Hz Volt							Direct Current Volt			Electrical connection	Connectors
	12	24	48	110	220 230	240	380	12	24	48		
Series 2 Width 30 Code ②	20A	20B	20C	20D	20E	20F	20G	200	201	202	DIN 43650A	PG9 code 10349000
Series 5 Width 36 Code ②	52A	52B	52C	52D	52E	52F	52G	520	521	522	DIN 43650A	PG11 code 10349001

**DESCRIPTION**  
 Insulation class  
 Series 2=F Series 5=H  
 Voltage tolerance  
 AC +15% -10%  
 DC ± 10%  
 Protection class  
 IP65 with connector fitted  
 IP00 without connector  
 Continuous service ED100%

**OPTIONS**  
 Class H insulation (series 2)  
 Cable attached  
 Special coil voltages  
 Special coil powers

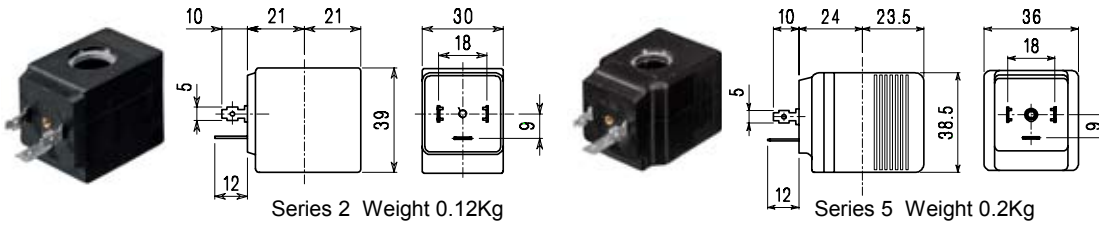

### SPARE PARTS

1. Coil fixing nut
2. Coil
3. Seal assembly
4. Armature tube

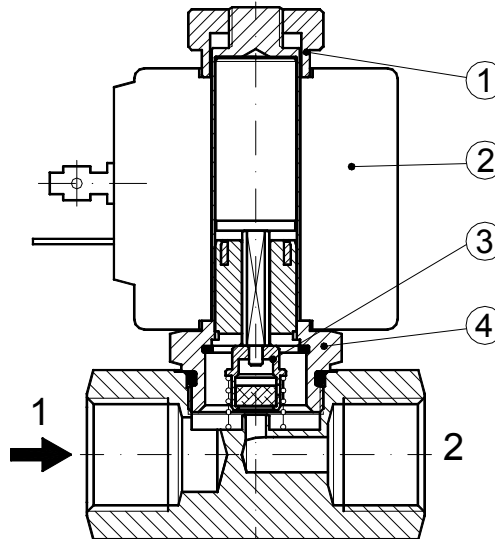

### OVERALL DIMENSION

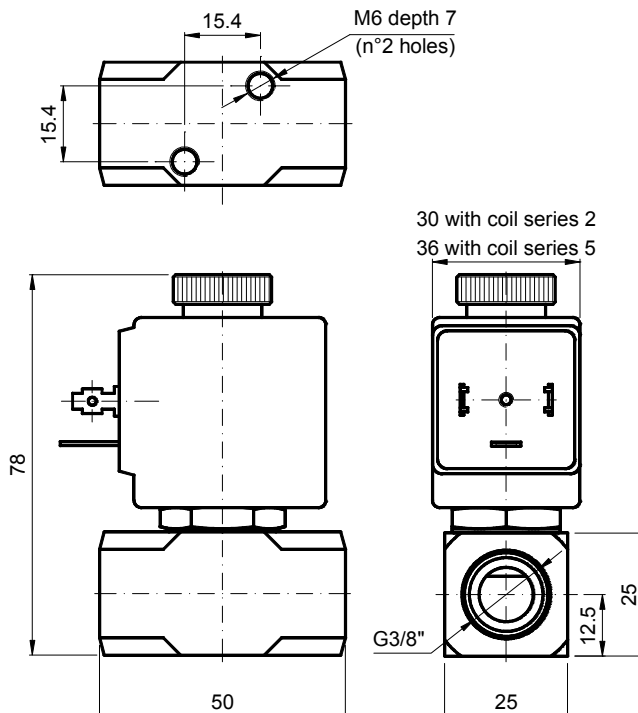

Weight with coil series 2 = 0.30 Kg  
 Weight with coil series 5 = 0.38 Kg



## DESCRIPTION

Solenoid valve 2 way normally open  
direct acting poppet type

## CONSTRUCTION

Body	Brass
Armature tube	Brass
Plunger and core	Stainless steel
Springs	Stainless steel
Seal material	NBR
	FPM
	EPDM



## FEATURES

Maximum allowable pressure 50 bar \*  
Maximum fluid viscosity 25cSt (mm<sup>2</sup>/s)  
Ambient temperature : with coil class F -10°C +55°C  
with coil class H -10°C +80°C  
Universal mounting position

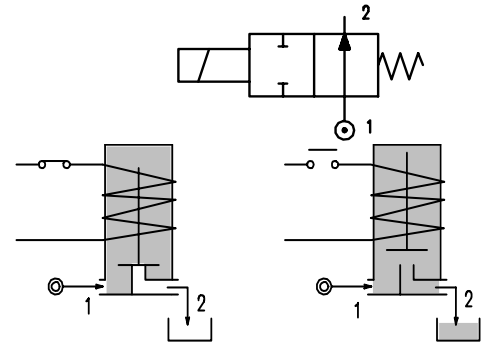

**OPTIONS :** Electroless nickel plating  
Stainless steel armature tube

CODE ① ②	Connection G ISO 228	Orifice mm	KV m <sup>3</sup> /h	Differential pressure bar			Nominal power			Coil		Seal ①	Temp. range °C
				Min	Max		AC Inrush	VA Holding	DC Watt	Series	Width		
					AC	DC							
E206D.....30///.....	1/2"	3	0.25	0	9	-	20	15	-	2	30	NBR=B	-10 +90
E206D.....35///.....		3.5	0.32	0	7	-							
E206D.....40///.....		4	0.36	0	5.5	-							
E206D.....45///.....		4.5	0.41	0	4.5	-							
E206D.....52///.....		5.2	0.47	0	3	-							
E206D.....30///.....	1/2"	3	0.25	0	9	9	40	30	27	5	36	EPDM=E	<+140
E206D.....35///.....		3.5	0.32	0	7	7							
E206D.....40///.....		4	0.36	0	5.5	5.5							
E206D.....45///.....		4.5	0.41	0	4.5	4.5							
E206D.....52///.....		5.2	0.47	0	3	3							
E206D.....64///.....		6.4	0.64	0	3.5	3.5							
D206D.....30/3/.....	1/2"	3	0.25	0	-	6.5	-	-	10	2	30	FPM=V	-10 +130
D206D.....35/3/.....		3.5	0.32	0	-	4							
D206D.....40/3/.....		4	0.36	0	-	3.5							
D206D.....45/3/.....		4.5	0.41	0	-	3							
D206D.....52/3/.....		5.2	0.47	0	-	2.2							

① Seal Example: E206DB45///20E NBR seal  
② Coil Coil 220V 50/60Hz

\* REMARK: The maximum allowable pressure PS for steam is 2,5bar (gauge pressure)

COILS	Alternating Current ~50/60Hz Volt							Direct Current Volt			Electrical connection	Connectors
	12	24	48	110	220 230	240	380	12	24	48		
Series 2 Width 30 Code ②	20A	20B	20C	20D	20E	20F	20G	200	201	202	DIN 43650A	PG9 code 10349000
Series 5 Width 36 Code ②	52A	52B	52C	52D	52E	52F	52G	520	521	522	DIN 43650A	PG11 code 10349001

**DESCRIPTION**  
 Insulation class  
 Series 2=F Series 5=H  
 Voltage tolerance  
 AC +15% -10%  
 DC ± 10%  
 Protection class  
 IP65 with connector fitted  
 IP00 without connector  
 Continuous service ED100%

**OPTIONS**  
 Class H insulation (series 2)  
 Cable attached  
 Special coil voltages  
 Special coil powers

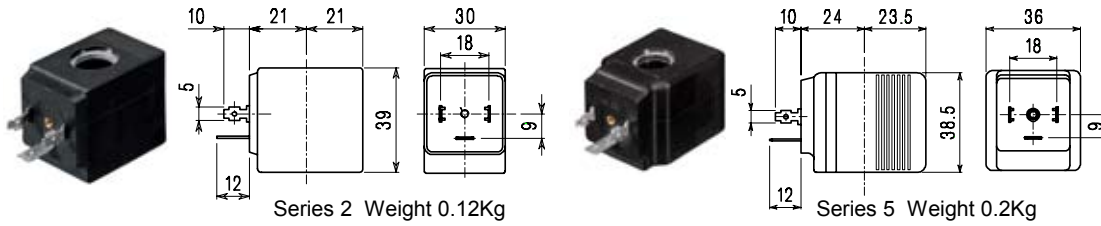

### SPARE PARTS

1. Coil fixing nut
2. Coil
3. Seal assembly
4. Armature tube

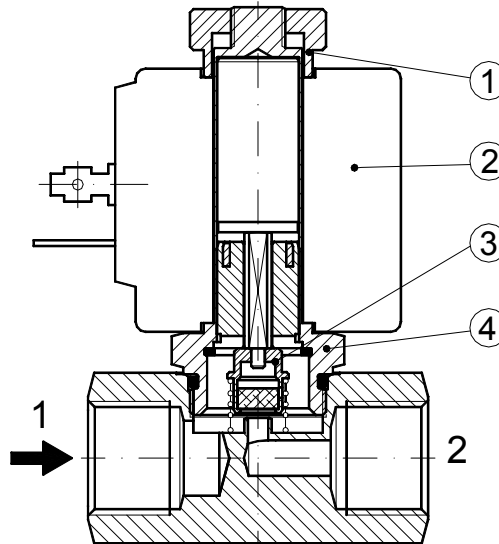

### OVERALL DIMENSION

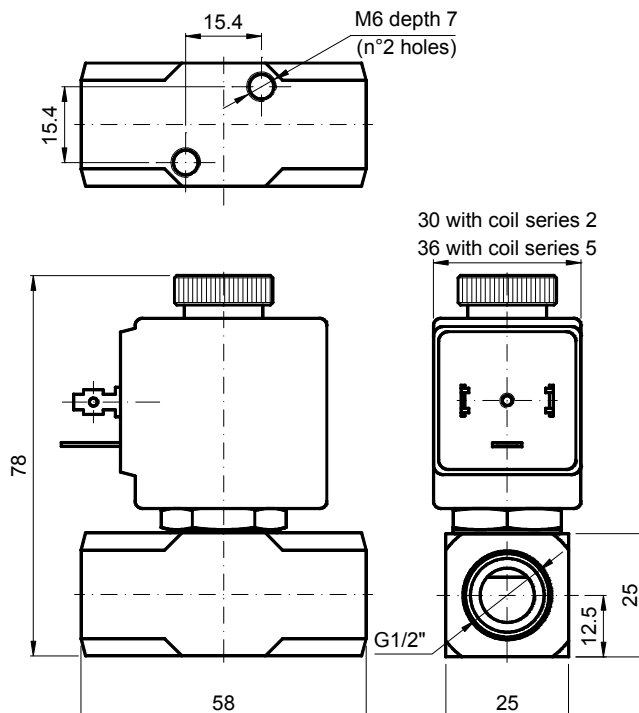

Weight with coil series 2 = 0.30 Kg  
 Weight with coil series 5 = 0.38 Kg

**DESCRIPTION**

Solenoid valve 2 way normally open  
direct acting poppet type

**CONSTRUCTION**

Body	Stainless steel
Armature tube	Stainless steel
Plunger and core	Stainless steel
Springs	Stainless steel
Seal material	NBR
	FPM
	EPDM



**2**

**FEATURES**

Maximum allowable pressure 50 bar \*  
Maximum fluid viscosity 25cSt (mm<sup>2</sup>/s)  
Ambient temperature : with coil class F -10°C +55°C  
with coil class H -10°C +80°C  
Universal mounting position

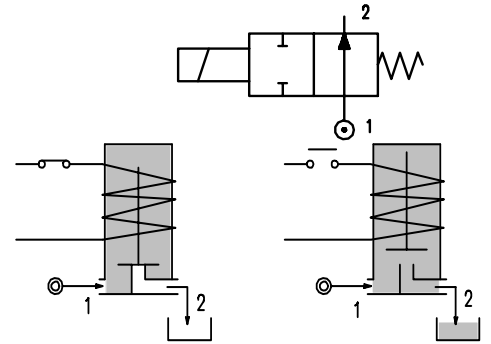

**OPTIONS :** Silver shading ring

CODE ① ②	Connection G ISO 228	Orifice mm	KV m <sup>3</sup> /h	Differential pressure bar			Nominal power			Coil		Seal ①	Temp. range °C
				Min	Max		AC Inrush	VA Holding	DC Watt	Series	Width		
					AC	DC							
E210B.....20///.....	1/4"	2	0.1	0	16	-	20	15	-	2	30	NBR=B	-10 +90
E210B.....25///.....		2.5	0.15	0	10	-							
E210B.....35///.....		3.5	0.32	0	7	-							
E210B.....45///.....		4.5	0.41	0	4.5	-							
E210B.....52///.....		5.2	0.47	0	3	-							
E210B.....20///.....	1/4"	2	0.1	0	16	16	40	30	27	5	36	EPDM=E	<+140
E210B.....25///.....		2.5	0.15	0	10	10							
E210B.....35///.....		3.5	0.32	0	7	7							
E210B.....45///.....		4.5	0.41	0	4.5	4.5							
E210B.....52///.....		5.2	0.47	0	3	3							
D210B.....20///.....	1/4"	2	0.1	0	-	16	-	-	10	2	30	FPM=V	-10 +130
D210B.....25///.....		2.5	0.15	0	-	10							
D210B.....35/3/.....		3.5	0.32	0	-	4							
D210B.....45/3/.....		4.5	0.41	0	-	3							
D210B.....52/3/.....		5.2	0.47	0	-	2.2							

① Seal Example: E210BB45///20E NBR seal  
② Coil Coil 220V 50/60Hz

\* REMARK: The maximum allowable pressure PS for steam is 2,5bar (gauge pressure)

COILS	Alternating Current ~50/60Hz Volt							Direct Current Volt			Electrical connection	Connectors
	12	24	48	110	220 230	240	380	12	24	48		
Series 2 Width 30 Code ②	20A	20B	20C	20D	20E	20F	20G	200	201	202	DIN 43650A	PG9 code 10349000
Series 5 Width 36 Code ②	52A	52B	52C	52D	52E	52F	52G	520	521	522	DIN 43650A	PG11 code 10349001

**DESCRIPTION**  
 Insulation class  
 Series 2=F Series 5=H  
 Voltage tolerance  
 AC +15% -10%  
 DC ± 10%  
 Protection class  
 IP65 with connector fitted  
 IP00 without connector  
 Continuous service ED100%

**OPTIONS**  
 Class H insulation (series 2)  
 Cable attached  
 Special coil voltages  
 Special coil powers

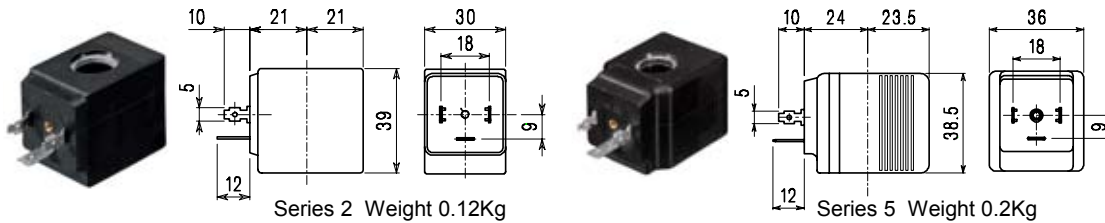

### SPARE PARTS

1. Coil fixing nut
2. Coil
3. Seal assembly
4. Armature tube

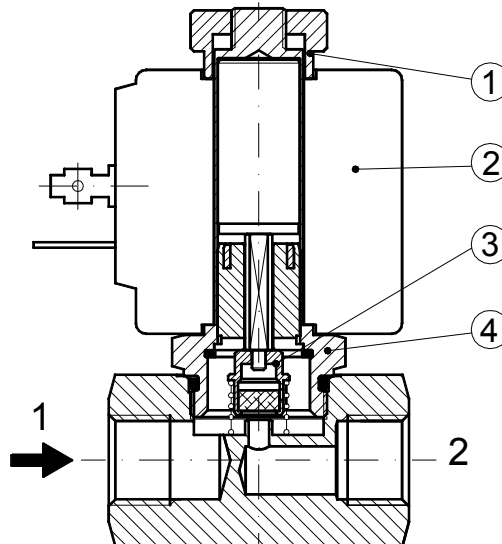

### OVERALL DIMENSION

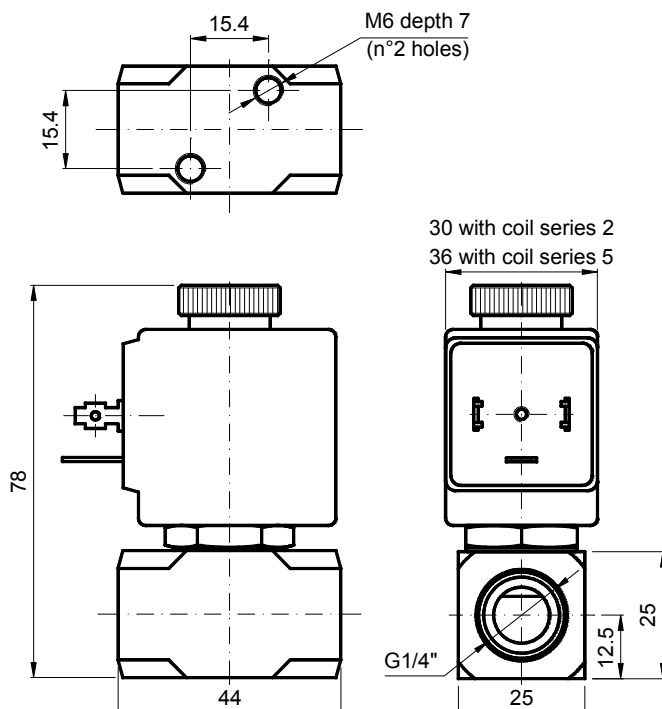

Weight with coil series 2 = 0.30 Kg  
 Weight with coil series 5 = 0.38 Kg

### DESCRIPTION

Solenoid valve 2 way normally open  
direct acting poppet type

### CONSTRUCTION

Body	Stainless steel
Armature tube	Stainless steel
Plunger and core	Stainless steel
Springs	Stainless steel
Seal material	NBR
	FPM
	EPDM



2

### FEATURES

Maximum allowable pressure 50 bar \*  
Maximum fluid viscosity 25cSt (mm<sup>2</sup>/s)  
Ambient temperature : with coil class F -10°C +55°C  
with coil class H -10°C +80°C  
Universal mounting position

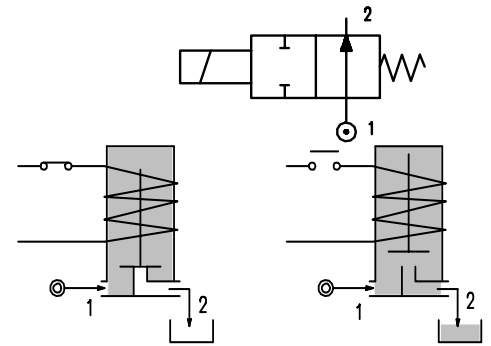

**OPTIONS :** Silver shading ring

CODE ① ②	Connection G ISO 228	Orifice mm	KV m <sup>3</sup> /h	Differential pressure bar			Nominal power			Coil		Seal ①	Temp. range °C
				Min	Max		AC Inrush	VA Holding	DC Watt	Series	Width		
					AC	DC							
E210C.....20///.....	3/8"	2	0.1	0	16	-	20	15	-	2	30	NBR=B	-10 +90
E210C.....35///.....		3.5	0.32	0	7	-							
E210C.....52///.....		5.2	0.47	0	3	-							
E210D.....20///.....	1/2"	2	0.1	0	16	-	40	30	27	5	36	EPDM=E	<+140
E210D.....35///.....		3.5	0.32	0	7	-							
E210D.....52///.....		5.2	0.47	0	3	-							
E210C.....20///.....	3/8"	2	0.1	0	16	16	-	-	10	2	30	FPM=V	-10 +130
E210C.....35///.....		3.5	0.32	0	7	7							
E210C.....52///.....		5.2	0.47	0	3	3							
E210C.....64///.....	1/2"	6.4	0.64	0	3.5	3.5	-	-	10	2	30	FPM=V	-10 +130
E210D.....20///.....		2	0.1	0	16	16							
E210D.....35///.....		3.5	0.32	0	7	7							
E210D.....52///.....	1/2"	5.2	0.47	0	3	3	-	-	10	2	30	FPM=V	-10 +130
E210D.....64///.....		6.4	0.64	0	3.5	3.5							
D210C.....20///.....		3/8"	2	0.1	0	-							
D210C.....35/3/.....	3.5		0.32	0	-	4							
D210C.....52/3/.....	5.2		0.47	0	-	2.2							
D210D.....20///.....	1/2"	2	0.1	0	-	16	-	-	10	2	30	FPM=V	-10 +130
D210D.....35/3/.....		3.5	0.32	0	-	4							
D210D.....52/3/.....		5.2	0.47	0	-	2.2							

① Seal Example: E210CB52///20E NBR seal  
② Coil Coil 220V 50/60Hz

\* REMARK: The maximum allowable pressure PS for steam is 2,5bar (gauge pressure)

COILS	Alternating Current ~50/60Hz Volt							Direct Current Volt			Electrical connection	Connectors
	12	24	48	110	220 230	240	380	12	24	48		
Series 2 Width 30 Code ②	20A	20B	20C	20D	20E	20F	20G	200	201	202	DIN 43650A	PG9 code 10349000
Series 5 Width 36 Code ②	52A	52B	52C	52D	52E	52F	52G	520	521	522	DIN 43650A	PG11 code 10349001

**DESCRIPTION**  
 Insulation class  
 Series 2=F Series 5=H  
 Voltage tolerance  
 AC +15% -10%  
 DC ± 10%  
 Protection class  
 IP65 with connector fitted  
 IP00 without connector  
 Continuous service ED100%

**OPTIONS**  
 Class H insulation (series 2)  
 Cable attached  
 Special coil voltages  
 Special coil powers

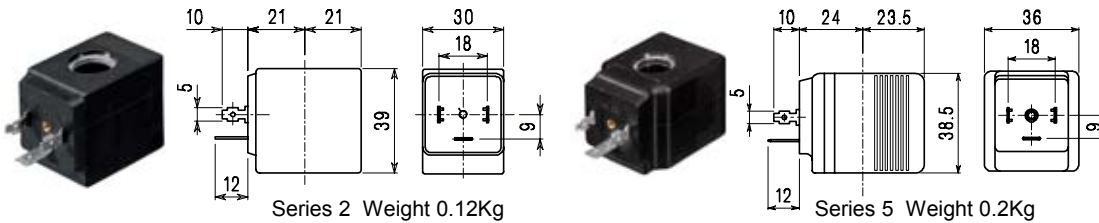

### SPARE PARTS

1. Coil fixing nut
2. Coil
3. Seal assembly
4. Armature tube

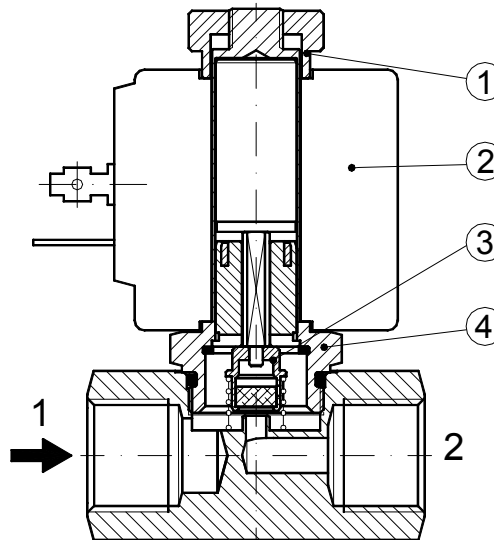

### OVERALL DIMENSION

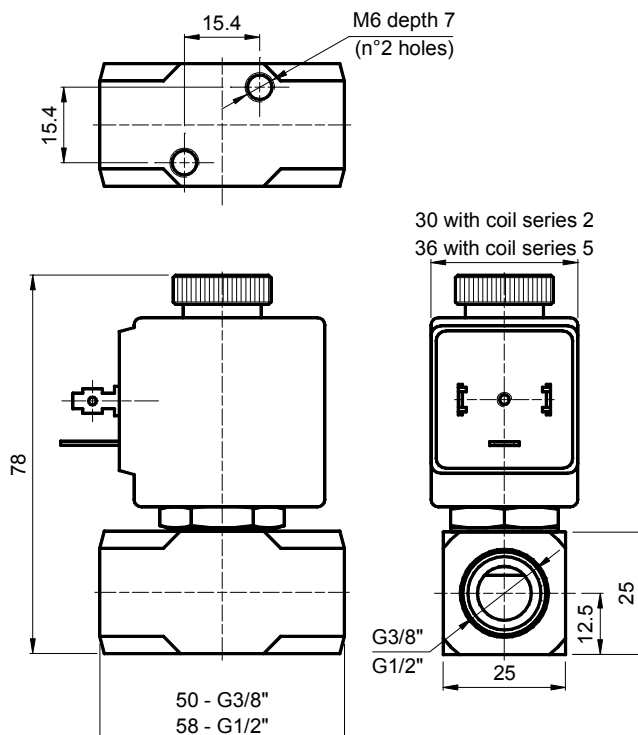

Weight with coil series 2 = 0.30 Kg  
 Weight with coil series 5 = 0.38 Kg

**DESCRIPTION**

Solenoid valve 2 way normally open  
open direct acting poppet type.

**CONSTRUCTION**

Body	Stainless steel
Armature tube	Stainless steel
Plunger and core	Stainless steel
Springs	Stainless steel
Seal material	NBR
	FPM
	EPDM



**2**

**FEATURES**

- Maximum allowable pressure 50 bar \*
- Maximum fluid viscosity 25cSt (mm<sup>2</sup>/s)
- Ambient temperature : with class F coil -10°C +55°C  
with class H coil -10°C +80°C
- Universal mounting position

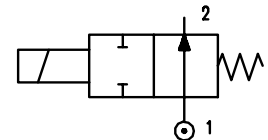

- OPTIONS :** Stainless steel armature tube  
Electroless nickel plating  
Explosion proof coil according to ATEX - EExmII Series 7

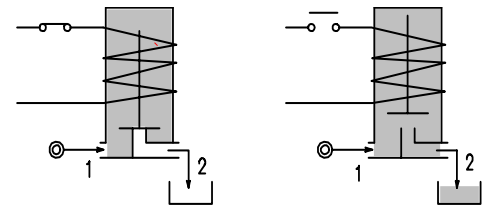

CODE ① ②	Connection G ISO 228	Orifice mm	KV m <sup>3</sup> /h	Differential pressure bar			Nominal power			Coil		Seal ①	Temp. range °C
				Min	Max		AC Inrush	VA Holding	DC Watt	Series	Width		
					AC	DC							
E211A.....12///.....	1/8"	1.2	0.04	0	19	19	12	8	6.5	3	22	NBR=B	-10 +90
E211A.....15///.....		1.5	0.06	0	14	14						EPDM=E	<+140
E211A.....20///.....		2	0.09	0	8	8						FPM=V	-10 +130
E211A.....25///.....		2.5	0.14	0	4.5	4.5							
E211A.....31///.....		3.1	0.19	0	2.5	2.5							

- ① Seal
  - ② Coil
- Example: E211AB20///30B NBR seal  
Coil 24V 50/60Hz

\* REMARK: The maximum allowable pressure PS for steam is 2,5bar (gauge pressure)

COILS	Alternating Current ~50/60Hz Volt							Direct Current Volt			Electrical connection	Connectors
	12	24	48	110	220 230	240	380	12	24	48		
Series 3 Width 22 Code ②	30A	30B	30C	30D	30E	30F	30G	300	301	302	DIN 46244	PG9 code 10348000

**DESCRIPTION**  
 Class F insulation  
 Voltage tolerance  
 AC +15% -10%  
 DC ± 10%  
 Protection class  
 IP65 with connector fitted  
 IP00 without connector  
 Continuous service ED100%

**OPTIONS**  
 Class H insulation  
 Cable attached  
 Special coil voltages  
 Special coil powers

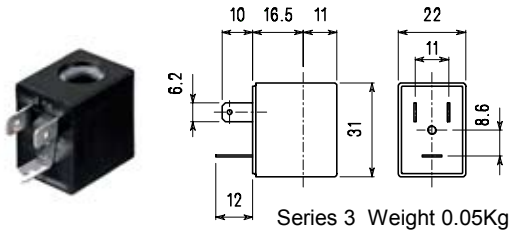

### SPARE PARTS LIST

1. Coil fixing nut
2. Coil
3. Seal assembly
4. Armature tube with core

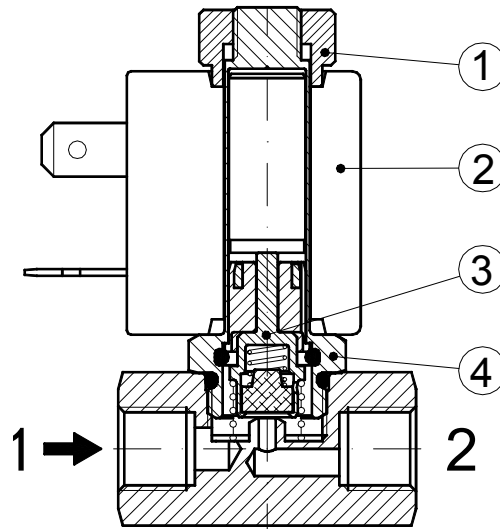

### OVERALL DIMENSION

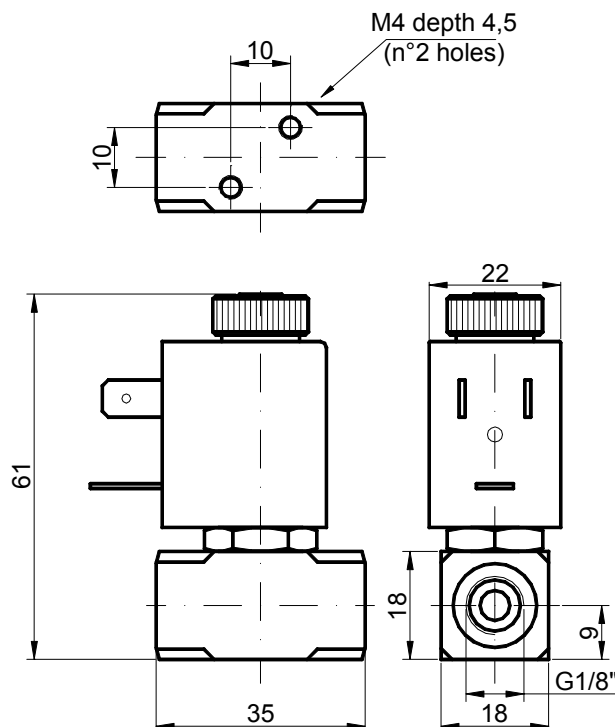



**DESCRIPTION**

Solenoid valve 2 way normally open direct acting poppet type.

**CONSTRUCTION**

Body	Brass
Armature tube	Brass
Plunger and core	Stainless steel
Springs	Stainless steel
Seal material	NBR
	FPM
	EPDM



**2**

**FEATURES**

Maximum allowable pressure 50 bar \*  
 Maximum fluid viscosity 25cSt (mm<sup>2</sup>/s)  
 Ambient temperature : with class F coil -10°C +55°C  
 with class H coil -10°C +80°C  
 Universal mounting position

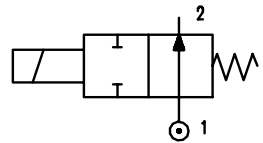

**OPTIONS :** Stainless steel armature tube  
 Electroless nickel plating  
 Explosion proof coil according to ATEX - EExmII Series 7

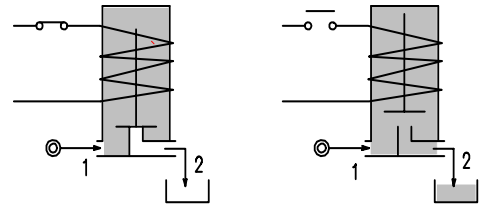

CODE ① ②	Flange	Orifice mm	KV m <sup>3</sup> /h	Differential pressure bar			Nominal power			Coil		Seal ①	Temp. Range °C
				Min	Max		AC Inrush	VA Holding	DC Watt	Series	Width		
					AC	DC							
E212X.....12///.....	Q25	1.2	0.04	0	19	19	12	8	6.5	3	22	NBR=B EPDM=E FPM=V	-10 +90 <+140 -10 +130
E212X.....15///.....		1.5	0.06	0	14	14							
E212X.....20///.....		2	0.09	0	8	8							
E212X.....25///.....		2.5	0.14	0	4.5	4.5							

① Seal Example: E212XB20///30B NBR seal  
 ② Coil Coil 24V 50/60Hz

Solenoid valve supplied without fixing screws

\* REMARK: The maximum allowable pressure PS for steam is 2,5bar (gauge pressure)

COILS	Alternating Current ~50/60Hz Volt							Direct Current Volt			Electrical connection	Connectors
	12	24	48	110	220 230	240	380	12	24	48		
Series 3 Width 22 Code ②	30A	30B	30C	30D	30E	30F	30G	300	301	302	DIN 46244	PG9 code 10348000

**DESCRIPTION**  
 Class F insulation  
 Voltage tolerance  
 AC +15% -10%  
 DC ± 10%  
 Protection class  
 IP65 with connector fitted  
 IP00 without connector  
 Continuous service ED100%

**OPTIONS**  
 Class H insulation  
 Cable attached  
 Special coil voltages  
 Special coil powers

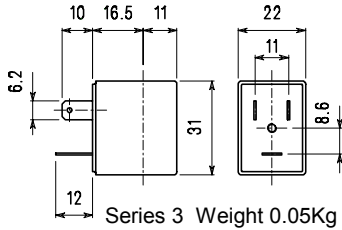

### SPARE PARTS LIST

1. Coil fixing nut
2. Coil
3. Seal assembly
4. Armature tube

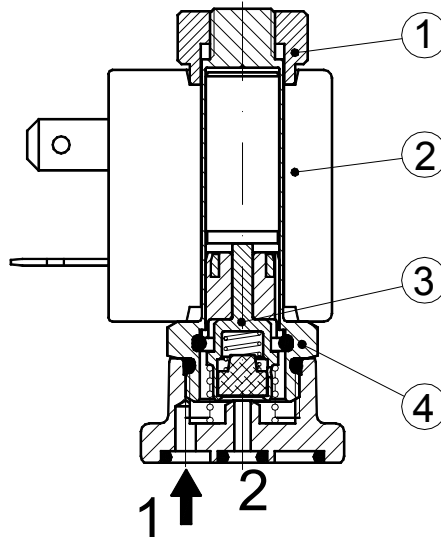

### OVERALL DIMENSION

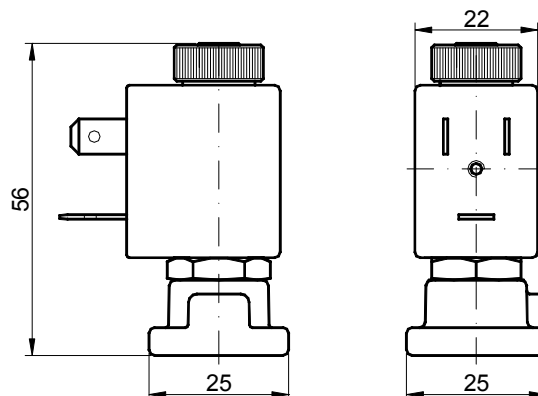
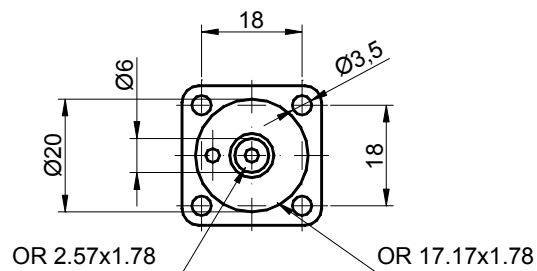

Weight = 0.12 Kg

**DESCRIPTION**

Solenoid valve 2 way normally open  
direct acting poppet type

**CONSTRUCTION**

Body	Brass
Armature tube	Brass
Plunger and core	Stainless steel
Springs	Stainless steel
Seal material	NBR
	FPM
	EPDM



**2**

**FEATURES**

Maximum allowable pressure 50 bar \*  
Maximum fluid viscosity 25cSt (mm<sup>2</sup>/s)  
Ambient temperature : with coil class F -10°C +55°C  
with coil class H -10°C +80°C  
Universal mounting position

**OPTIONS :** Electroless nickel plating  
Stainless steel armature tube

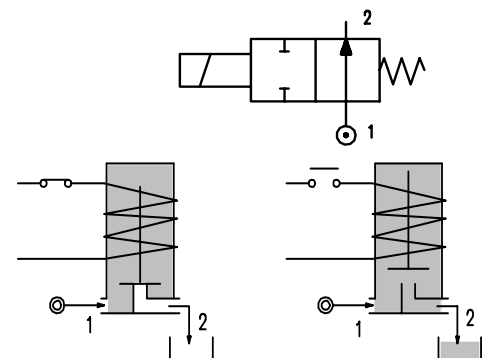

CODE ① ②	Flange	Orifice mm	KV m <sup>3</sup> /h	Differential pressure bar			Nominal power			Coil		Seal ①	Temp. range °C
				Min	Max		AC Inrush	VA Holding	DC W	Series	Width		
					AC	DC							
E214X.....15///.....	Q32	1.5	0.07	0	23	-	20	15	-	2	30	NBR=B	-10 +90
E214X.....20///.....		2	0.1	0	17	-							
E214X.....25///.....		2.5	0.15	0	12	-							
E214X.....35///.....		3.5	0.32	0	7	-							
E214X.....45///.....		4.5	0.41	0	4.5	-							
E214X.....15///.....	Q32	1.5	0.07	0	23	23	40	30	27	5	36	EPDM=E	<+140
E214X.....20///.....		2	0.1	0	17	17							
E214X.....25///.....		2.5	0.15	0	12	12							
E214X.....35///.....		3.5	0.32	0	7	7							
E214X.....45///.....		4.5	0.41	0	4.5	4.5							
D214X.....15/5/.....	Q32	1.5	0.07	0	-	18	-	-	10	2	30	FPM=V	-10 +130
D214X.....20/5/.....		2	0.1	0	-	11							
D214X.....25/5/.....		2.5	0.15	0	-	7							
D214X.....35/5/.....		3.5	0.32	0	-	4							
D214X.....45/5/.....		4.5	0.41	0	-	3							

① Seal Example: E214XV52///20B FPM seal  
② Coil Coil 24V 50/60Hz

Solenoid valve supplied without fixing screws

\* REMARK: The maximum allowable pressure PS for steam is 2,5bar (gauge pressure)

COILS	Alternating Current ~50/60Hz Volt							Direct Current Volt			Electrical connection	Connectors
	12	24	48	110	220 230	240	380	12	24	48		
Series 2 Width 30 Code ②	20A	20B	20C	20D	20E	20F	20G	200	201	202	DIN 43650A	PG9 code 10349000
Series 5 Width 36 Code ②	52A	52B	52C	52D	52E	52F	52G	520	521	522	DIN 43650A	PG11 code 10349001

**DESCRIPTION**  
 Insulation class  
 Series 2=F Series 5=H  
 Voltage tolerance  
 AC +15% -10%  
 DC ± 10%  
 Protection class  
 IP65 with connector fitted  
 IP00 without connector  
 Continuous service ED100%

**OPTIONS**  
 Class H insulation (series 2)  
 Cable attached  
 Special coil voltages  
 Special coil powers

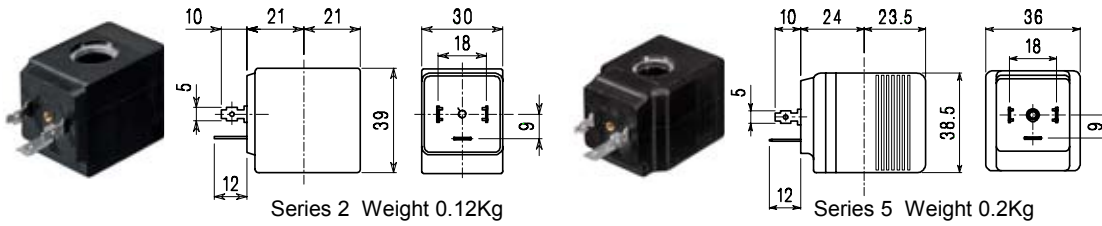

### SPARE PARTS

1. Coil fixing nut
2. Coil
3. Seal assembly
4. Armature tube

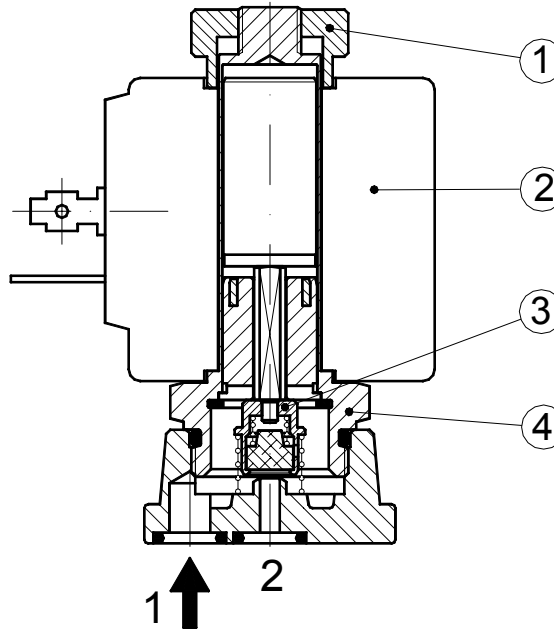

### OVERALL DIMENSION

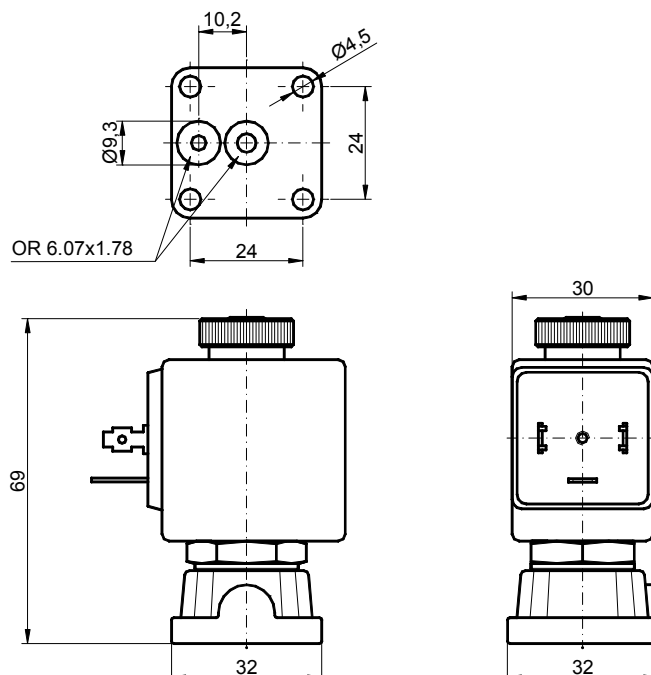

Weight with coil series 2 = 0.25 Kg  
 Weight with coil series 5 = 0.33 Kg

### DESCRIPTION

Solenoid valve 2 way normally open direct acting poppet type, suitable for food application and all compatible fluids.

### CONSTRUCTION

Body	Thermoplastic polymer: NSF, WRC, KTW, FDA certified
Armature tube	Brass chemically nickel plated
Plunger and core	Stainless steel
Springs	Stainless steel
Seal material	NBR food contact certified FPM food contact certified EPDM food contact certified



2

### FEATURES

Maximum allowable pressure 20 bar \*  
 Maximum fluid viscosity 25cSt (mm<sup>2</sup>/s)  
 Ambient temperature : with class F coil -10°C +55°C  
 with class H coil -10°C +80°C  
 Universal mounting position

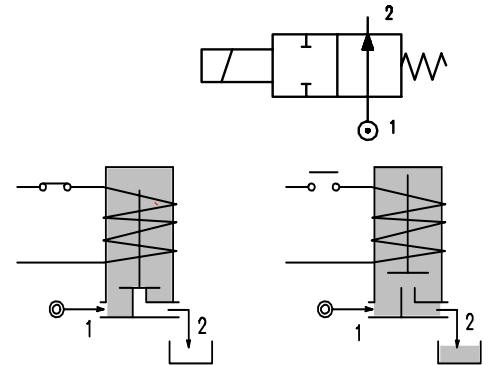

**OPTIONS :** Stainless steel armature tube  
 Type N connection without nut

CONNECTIONS					
K	N	P	W ③	Y	Z
<b>SPIGGOT</b>	<b>G1/8" male thread with NUT for flexible and semiflexible pipes</b>	<b>HOSETAIL for flexible pipes</b>	<b>COMPRESSION for flexible and semiflexible pipes</b>	<b>PUSH IN for semiflexible pipes Øext.6</b>	<b>PUSH IN for semiflexible pipes Øext.4</b>

CODE ① ②	Connection *	Orifice mm	KV m <sup>3</sup> /h	Differential pressure bar			Nominal power			Coil		Seal ①	Temperature range ** °C
				Min	Max		AC Inrush	VA Holding	DC Watt	Series	Width		
					AC	DC							
E235*.....15///.....	K-N-P-W-Y-Z	1.5	0.06	0	14	14	12	8	6.5	3	22	NBR=A	-10 +90
E235*.....20///.....	K-N-P-W-Y-Z	2	0.09	0	8	8						EPDM=E	<+140
E235*.....25///.....	K-N-P-W-Y-Z	2.5	0.14	0	4.5	4.5						FPM=V	-10 +130

- ① Seal
  - ② Coil
  - ③ Only for connection "W"
- Example: E235PV20///30E FPM seal HOSETAIL connection  
 Coil 230V 50/60Hz  
 E235W..../1/....

REMARK: The maximum allowable pressure PS for steam is 2,5bar (gauge pressure)

\*\* The temperature range is related to the material of the seals (NBR, EPDM, FPM), and the valves' body. Please contact us concerning the temperature range referred to the different types of connection.

COILS	Alternating Current ~50/60Hz Volt							Direct Current Volt			Electrical connection	Connectors
	12	24	48	110	220 230	240	380	12	24	48		
Series 3 Width 22 Code ②	30A	30B	30C	30D	30E	30F	30G	300	301	302	DIN 46244	PG9 code 10348000

**DESCRIPTION**  
 Class F insulation  
 Voltage tolerance  
 AC +15% -10%  
 DC ± 10%  
 Protection class  
 IP65 with connector fitted  
 IP00 without connector  
 Continuous service ED100%

**OPTIONS**  
 Class H insulation  
 Cable attached  
 Special coil voltages  
 Special coil powers

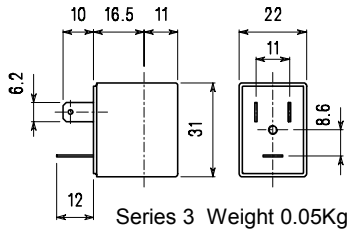

### SPARE PARTS LIST

1. Coil fixing nut
2. Coil
3. Seal assembly
4. Armature tube with core

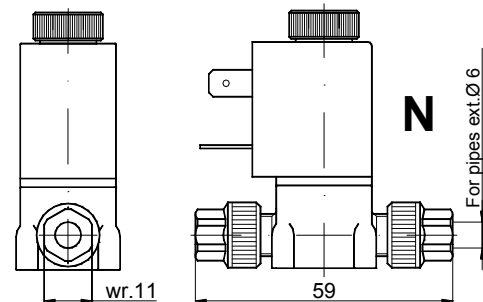
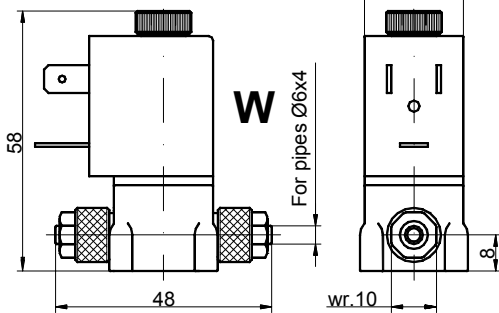
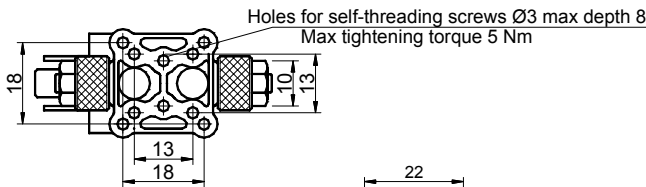
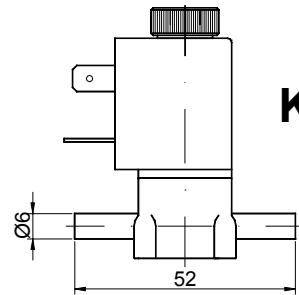
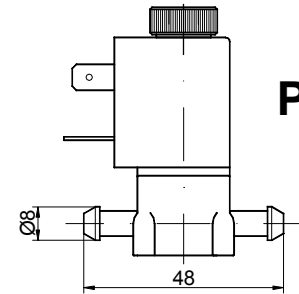
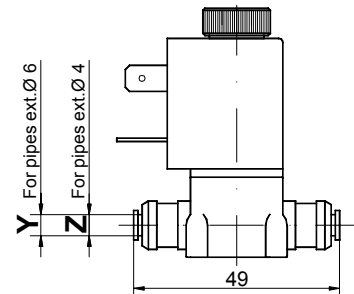
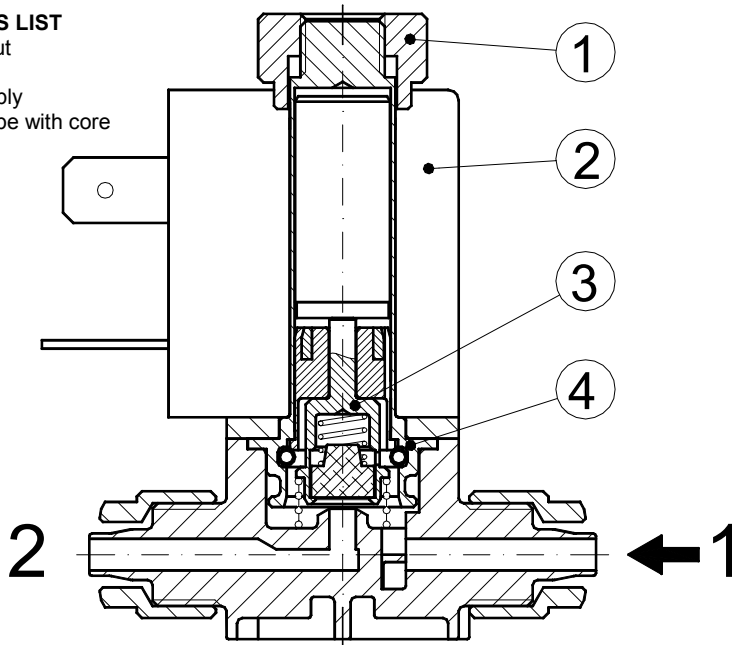

Screw the nut with wrench 11 up to the sliding on the hexagon (TORQUE LIMITING DEVICE)

Weight = 0.10 Kg

### DESCRIPTION

Solenoid valve 3 way  
direct acting poppet type

### CONSTRUCTION

Body	Brass
Armature tube	Brass
Plunger and core	Stainless steel
Springs	Stainless steel
Seal material	NBR
	FPM
	EPDM



### FEATURES

Maximum allowable pressure : maximum differential pressure +10%

Maximum fluid viscosity 25cSt (mm<sup>2</sup>/s)

Ambient temperature : with class F coil -10°C +55°C  
with class H coil -10°C +80°C

Universal mounting position

- OPTIONS :** Stainless steel armature tube  
Electroless nickel plating  
Explosion proof coil according to ATEX - EExmII Series7  
Exhaust port with hosedetail connection

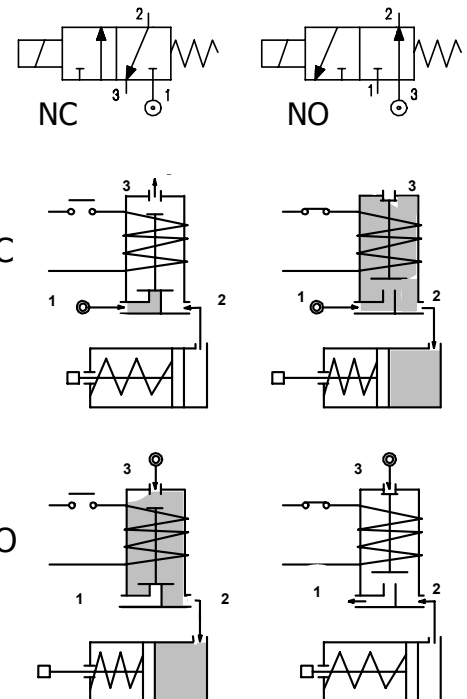

CODE ① ②	Connection G ISO 228	Orifice mm		KV m <sup>3</sup> /h	Differential pressure bar			Nominal power			Coil		Seal ①	Temp. range °C
		Inlet	Exh.		Min	Max		AC Inrush	VA Holding	DC Watt	Series	Width		
						AC	DC							
<b>NC Normally closed</b>														
E304A.....15///.....	1/8"	1.5	0.06	0	10	10	12	8	6.5	3	22	NBR=B EPDM=E FPM=V	-10 +90 <+140 -10 +130	
<b>NO Normally open</b>														
E304A.....15/S/.....	1/8"	1.5	0.06	0	10	10	12	8	6.5	3	22			

- ① Seal  
② Coil

Example: E304AV15///30B FPM seal Coil 24V 50/60Hz NC  
E304AB15/S/301 NBR seal Coil 24V DC NO

COILS	Alternating Current ~50/60Hz Volt							Direct Current Volt			Electrical connection	Connectors
	12	24	48	110	220 230	240	380	12	24	48		
Series 3 Width 22 Code ②	30A	30B	30C	30D	30E	30F	30G	300	301	302	DIN 46244	PG9 code 10348000

**DESCRIPTION**  
 Class F insulation  
 Voltage tolerance  
 AC +15% -10%  
 DC ± 10%  
 Protection class  
 IP65 with connector fitted  
 IP00 without connector  
 Continuous service ED100%

**OPTIONS**  
 Class H insulation  
 Cable attached  
 Special coil voltages  
 Special coil powers

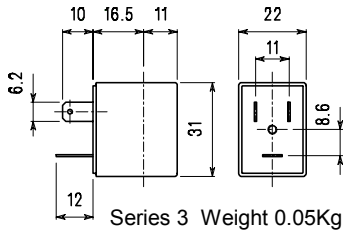

### SPARE PARTS LIST

1. Coil fixing nut
2. Coil
3. Plunger
4. Armature tube with core

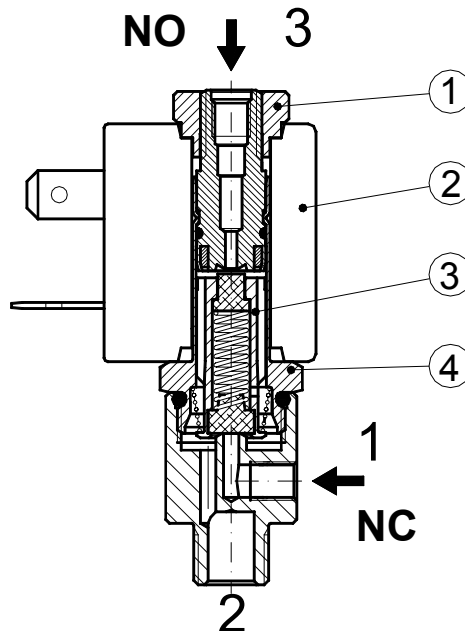

### OVERALL DIMENSION

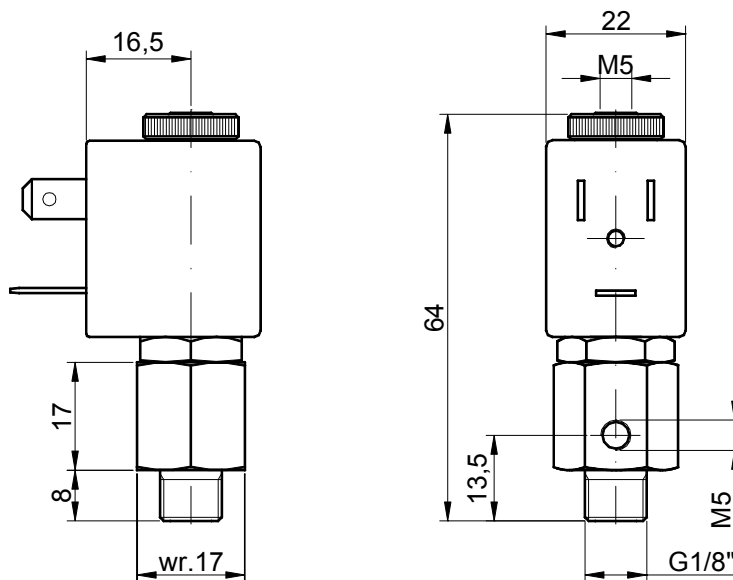

Weight = 0.11 Kg



### DESCRIPTION

Solenoid valve 3 way  
direct acting poppet type

### CONSTRUCTION

Body	Brass
Armature tube	Brass
Plunger and core	Stainless steel
Springs	Stainless steel
Seal material	NBR
	FPM
	EPDM

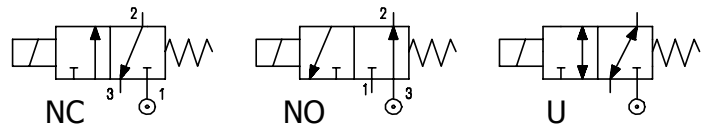

### FEATURES

- Maximum allowable pressure : maximum differential pressure+10%
- Maximum fluid viscosity 25cSt (mm<sup>2</sup>/s)
- Ambient temperature : with class F coil -10°C +55°C  
with class H coil -10°C +80°C
- Universal mounting position

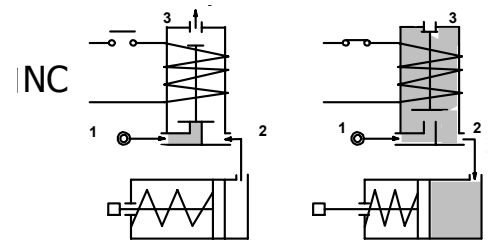

- OPTIONS :**
- Manual override
  - Stainless steel armature tube
  - Electroless nickel plating
  - Explosion proof coil according to ATEX - EExmII Series7
  - Exhaust port with hosetail connection

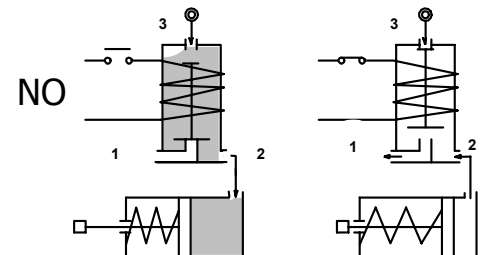

CODE ① ②	Connection G ISO 228	Orifice mm		KV m³/h	Differential pressure bar			Nominal power			Coil		Seal ①	Temp. range °C
		Inlet	Exh.		Min	Max		AC Inrush	VA Holding	DC Watt	Series	Width		
						AC	DC							
<b>NC Normally closed</b>														
E305A.....12///.....	1/8"	1.2	1.5	0.04	0	15	15	12	8	6.5	3	22	NBR=B	-10 +90
E305A.....15///.....		1.5	1.5	0.06	0	10	10							
E305A.....20///.....		2	1.7	0.09	0	6	6							
<b>NO Normally open</b>														
E305A.....15/S/.....	1/8"	1.5	1.5	0.06	0	10	10	12	8	6.5	3	22	EPDM=E	<+140
E305A.....17/S/.....		1.7	2	0.07	0	6	6							
<b>U Universal</b>														
E305A.....15/G/.....	1/8"	1.5	1.5	0.06	0	6	6	12	8	6.5	3	22	FPM=V	-10 +130

- ① Seal
- ② Coil

Example: E305AV15///30B FPM seal Coil 24V 50/60Hz NC  
E305AB15/S/301 NBR seal Coil 24V DC NO

COILS	Alternating Current ~50/60Hz Volt							Direct Current Volt			Electrical connection	Connectors
	12	24	48	110	220 230	240	380	12	24	48		
Series 3 Width 22 Code ②	30A	30B	30C	30D	30E	30F	30G	300	301	302	DIN 46244	PG9 code 10348000

**DESCRIPTION**  
 Class F insulation  
 Voltage tolerance  
 AC +15% -10%  
 DC ± 10%  
 Protection class  
 IP65 with connector fitted  
 IP00 without connector  
 Continuous service ED100%

**OPTIONS**  
 Class H insulation  
 Cable attached  
 Special coil voltages  
 Special coil powers

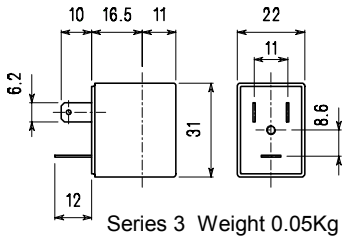

### SPARE PARTS LIST

1. Coil fixing nut
2. Coil
3. Plunger
4. Armature tube with core

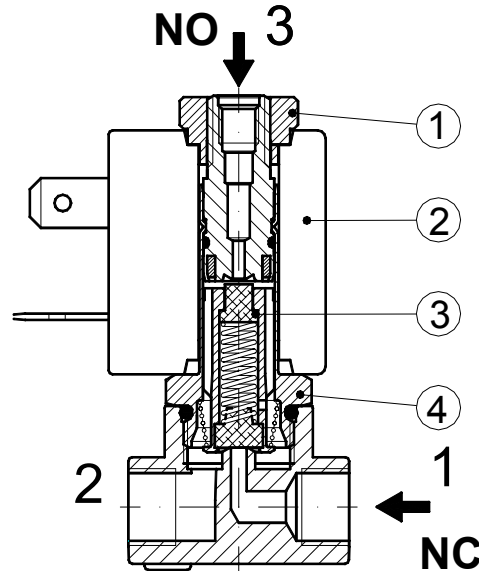

### MANUAL OVERRIDE

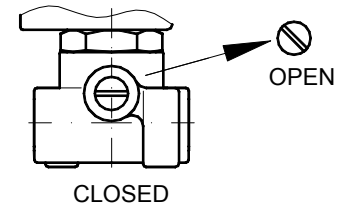

### OVERALL DIMENSION

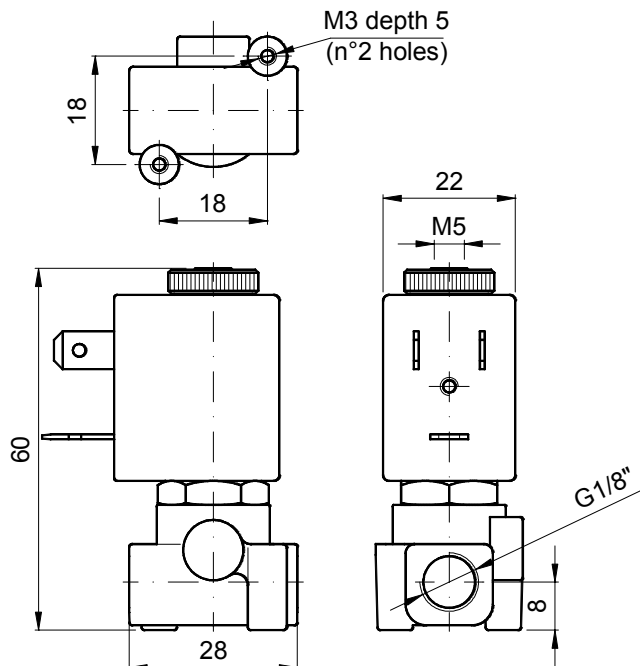

Weight = 0.13 Kg

**DESCRIPTION**

Solenoid valve 3 way  
direct acting poppet type

**CONSTRUCTION**

Body	Brass
Armature tube	Stainless steel
Plunger and core	Stainless steel
Springs	Stainless steel
Seal material	NBR FPM EPDM

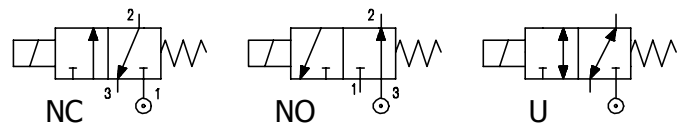

**FEATURES**

- Maximum allowable pressure : maximum differential pressure +10%
- Maximum fluid viscosity 25cSt (mm<sup>2</sup>/s)
- Ambient temperature : with class F coil -10°C +55°C  
with class H coil -10°C +80°C
- Universal mounting position

- OPTIONS :** Manual override  
Electroless nickel plating  
Stainless steel seat

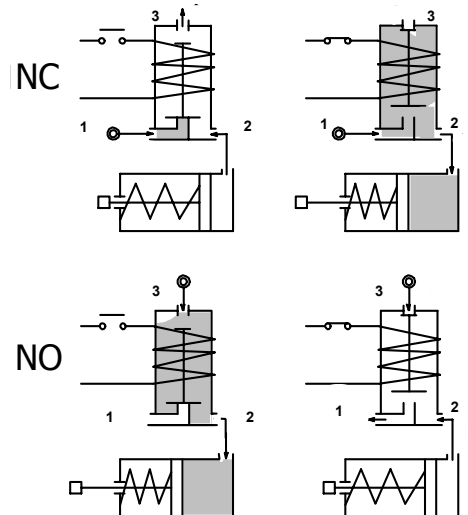

**3**

CODE ① ②	Connection G ISO 228	Orifice mm		KV m <sup>3</sup> /h	Differential pressure bar			Nominal power			Coil		Seal ①	Temp. range °C
		Inlet	Exh.		Min	Max		AC Inrush	VA Holding	DC Watt	Series	Width		
						AC	DC							
<b>NC Normally closed</b>														
E306A.....15///.....	1/8"	1.5	2.4	0.07	0	20	20	20	15	10	2	30	NBR=B EPDM=E FPM=V	-10 +90 <+140 -10 +130
E306A.....20///.....		2	2.4	0.11	0	13	13							
E306A.....25///.....		2.5	2.4	0.16	0	10	10							
E306B.....15///.....	1/4"	1.5	2.4	0.07	0	20	20	20	15	10	2	30		
E306B.....20///.....		2	2.4	0.11	0	13	13							
E306B.....25///.....		2.5	2.4	0.16	0	10	10							
<b>NO Normally open</b>														
E306B.....24/S/.....	1/4"	2.4	2.5	0.16	0	9	9	20	15	10	2	30	FPM=V	-10 +130
E306B.....29/S/.....		2.9	3	0.20	0	6.5	6.5							
<b>U Universal</b>														
E306B.....25/G/.....	1/4"	2.5	2.4	0.16	0	5	4	20	15	10	2	30		

- ① Seal
- ② Coil

Example: E306BV15///20B FPM seal Coil 24V 50/60Hz NC  
E306BB24/S/201 NBR seal Coil 24V DC NO

COILS	Alternating Current ~50/60Hz Volt							Direct Current Volt			Electrical connection	Connectors
	12	24	48	110	220 230	240	380	12	24	48		
Series 2 Width 30 Code ②	20A	20B	20C	20D	20E	20F	20G	200	201	202	DIN 43650A	PG9 code 10349000

**DESCRIPTION**  
 Class F insulation  
 Voltage tolerance  
 AC +15% -10%  
 DC ± 10%  
 Protection class  
 IP65 with connector fitted  
 IP00 without connector  
 Continuous service ED100%

**OPTIONS**  
 Class H insulation  
 Cable attached  
 Special coil voltages  
 Special coil powers

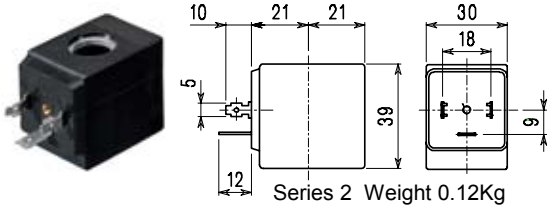

### SPARE PARTS LIST

1. Coil fixing nut
2. Coil
3. Plunger
4. Armature tube with core

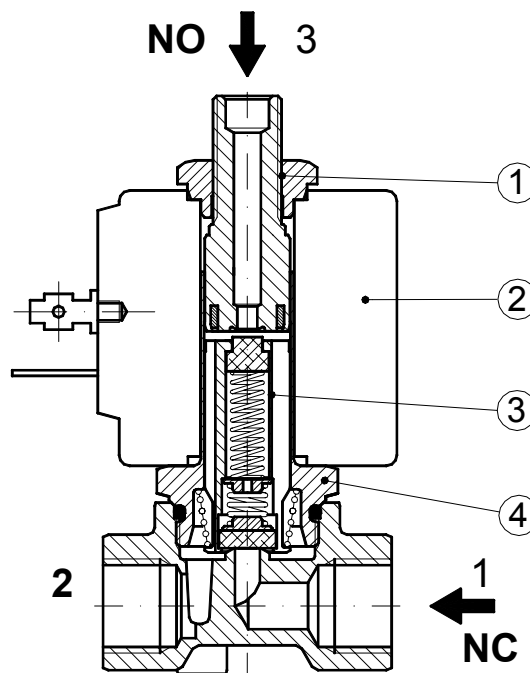

### MANUAL OVERRIDE

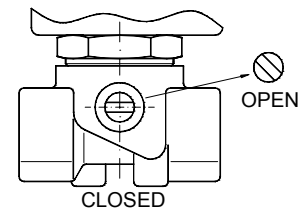

### OVERALL DIMENSION

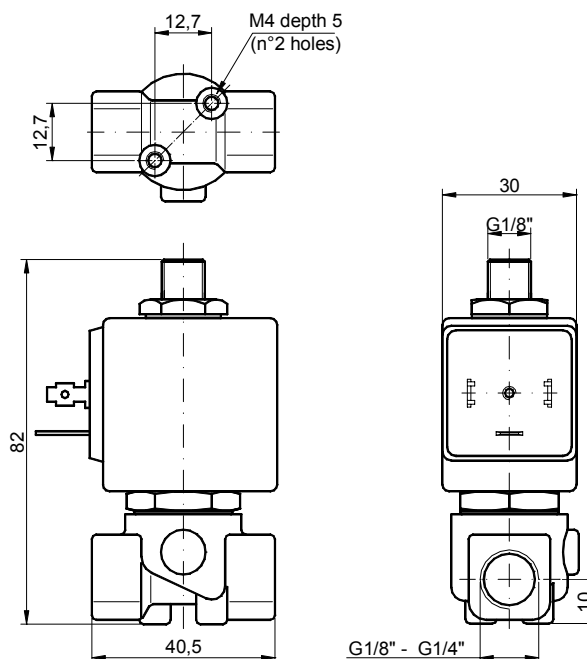

Weight = 0.32 Kg

### DESCRIPTION

Solenoid valve 3 way normally open direct acting poppet type

### CONSTRUCTION

Body	Brass
Armature tube	Brass
Plunger and core	Stainless steel
Springs	Stainless steel
Seal material	NBR
	FPM
	EPDM

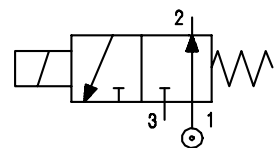

3

### FEATURES

Maximum allowable pressure : maximum differential pressure +10%

Maximum fluid viscosity 25cSt (mm<sup>2</sup>/s)

Ambient temperature : with class F coil -10°C +55°C  
with class H coil -10°C +80°C

Universal mounting position

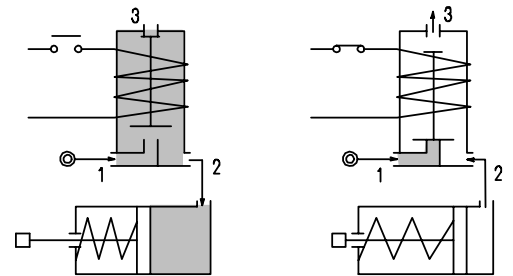

- OPTIONS :** Stainless steel armature tube  
Electroless nickel plating  
Explosion proof coil according to ATEX - EExmII Series 7  
Exhaust port with hosedetail connection

CODE ① ②	Connection G ISO 228	Orifice mm		KV m <sup>3</sup> /h	Differential pressure bar			Nominal power			Coil		Seal ①	Temp. range °C
		Inlet	Exh.		Min	Max		AC Inrush	VA Holding	DC Watt	Series	Width		
						AC	DC							
E307A.....12///.....	1/8"	1.2	1.2	0.04	0	12	8	12	8	6.5	3	22	NBR=B EPDM=E FPM=V	-10 +90 <+140 -10 +130
E307A.....15///.....	1/8"	1.5	1.2	0.06	0	9	6	12	8	6.5	3	22		

- ① Seal  
② Coil

Example: E307AV15///30B FPM seal  
Coil 24V 50/60Hz

COILS	Alternating Current ~50/60Hz Volt							Direct Current Volt			Electrical Connection	Connectors
	12	24	48	110	220 230	240	380	12	24	48		
Series 3 Width 22 Code ②	30A	30B	30C	30D	30E	30F	30G	300	301	302	DIN 46244	PG9 code 10348000

**DESCRIPTION**  
 Class F insulation  
 Voltage tolerance  
 AC +15% -10%  
 DC ± 10%  
 Protection class  
 IP65 with connector fitted  
 IP00 without connector  
 Continuous service ED100%

**OPTIONS**  
 Class H insulation  
 Cable attached  
 Special coil voltages  
 Special coil powers

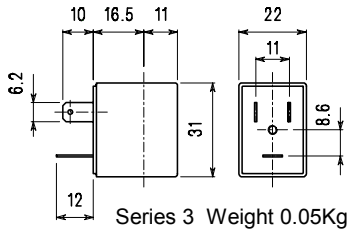

### SPARE PARTS LIST

1. Coil fixing nut
2. Coil
3. Seal assembly
4. Armature tube with core

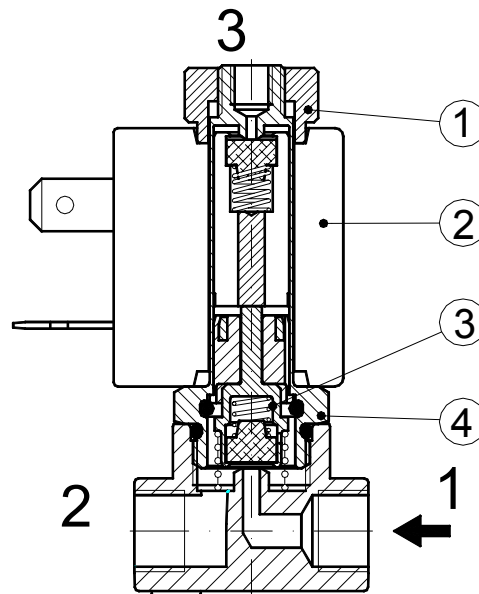

### OVERALL DIMENSION

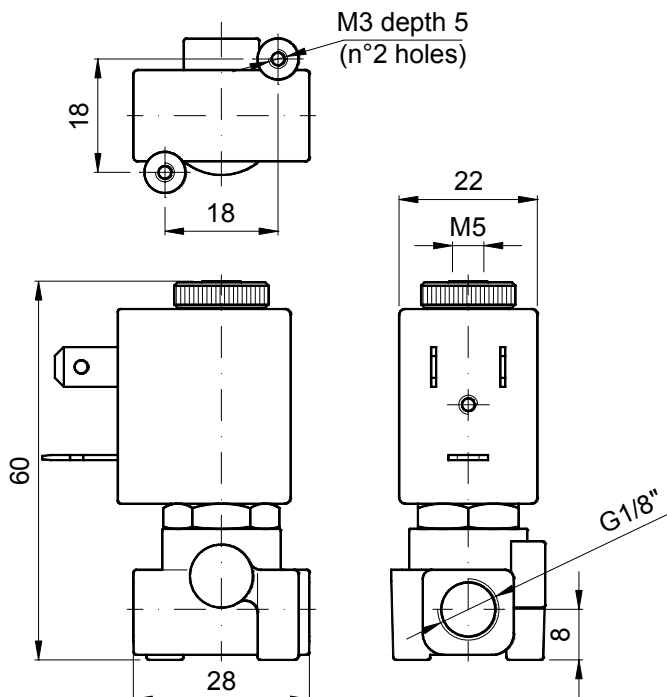

Weight = 0.13 Kg

### DESCRIPTION

Solenoid valve 3 way  
direct acting poppet type

### CONSTRUCTION

Body	Stainless steel
Armature tube	Stainless steel
Plunger and core	Stainless steel
Springs	Stainless steel
Seal material	NBR
	FPM
	EPDM

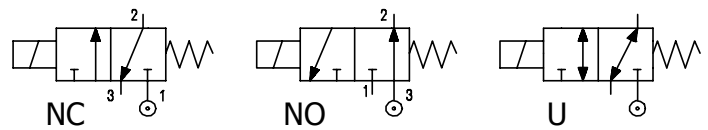

### FEATURES

Maximum allowable pressure : maximum differential pressure +10%

Maximum fluid viscosity 25cSt (mm<sup>2</sup>/s)

Ambient temperature : with class F coil -10°C +55°C  
with class H coil -10°C +80°C

Universal mounting position

**OPZIONI :** Silver shading ring

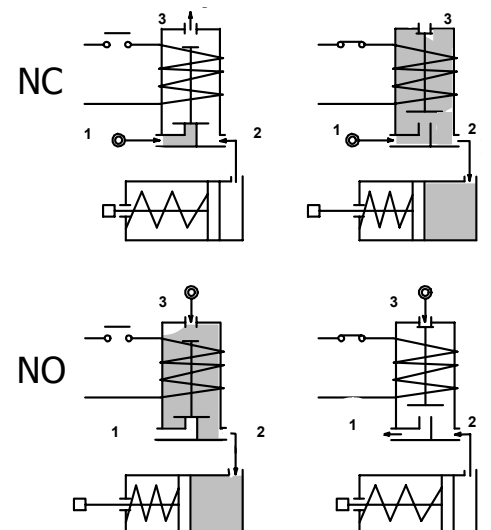

**3**

CODE ① ②	Connection G ISO 228	Orifice mm		KV m <sup>3</sup> /h	Differential pressure bar			Nominal power			Coil		Seal ①	Temp. range °C
		Inlet	Exh.		Min	Max		AC Inrush	VA Holding	DC Watt	Series	Width		
						AC	DC							
<b>NC Normally closed</b>														
E310B.....20///.....	1/4"	2	2.4	0.11	0	13	13	20	15	10	2	30	NBR=B	-10 +90
E310B.....25///.....		2.5	2.4	0.16	0	10	10							
<b>NA Normally open</b>														
E310B.....24/S/.....	1/4"	2.4	2.5	0.16	0	9	9	20	15	10	2	30	EPDM=E	<+140
E310B.....29/S/.....		2.9	3	0.20	0	6.5	6.5							
<b>U Universal</b>														
E310B.....25/G/.....	1/4"	2.5	2.4	0.16	0	5	4	20	15	10	2	30	FPM=V	-10 +130

- ① Seal
- ② Coil

Example: E310BV20///20B FPM seal Coil 24V 50/60Hz NC  
E310BB24/S/201 NBR seal Coil 24V DC NO

COIL	Alternating Current ~50/60Hz Volt							Direct Current Volt			Electrical connection	Connectors
	12	24	48	110	220 230	240	380	12	24	48		
Series 2 Width 30 Code ②	20A	20B	20C	20D	20E	20F	20G	200	201	202	DIN 43650A	PG9 code 10349000

**DESCRIPTION**  
 Class F insulation  
 Voltage tolerance  
 AC +15% -10%  
 DC ± 10%  
 Protection class  
 IP65 with connector fitted  
 IP00 without connector  
 Continuous service ED100%

**OPTIONS**  
 Class H insulation  
 Cable attached  
 Special coil voltages  
 Special coil powers

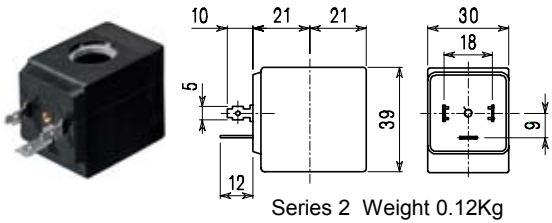

### SPARE PARTS LIST

1. Coil fixing nut
2. Coil
3. Plunger
4. Armature tube with core

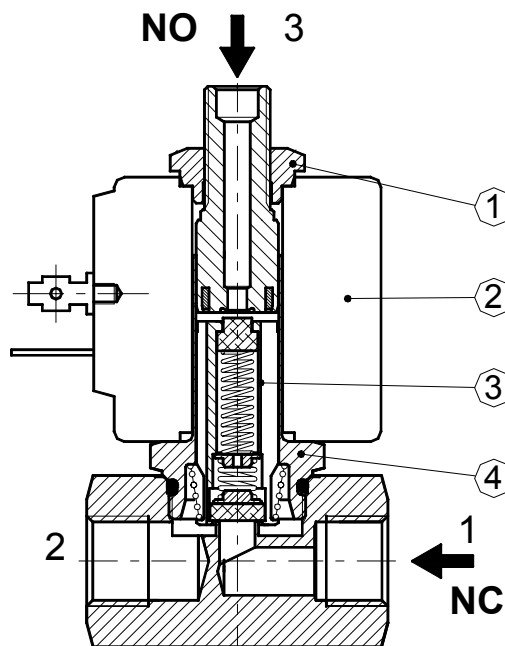

### OVERALL DIMENSION

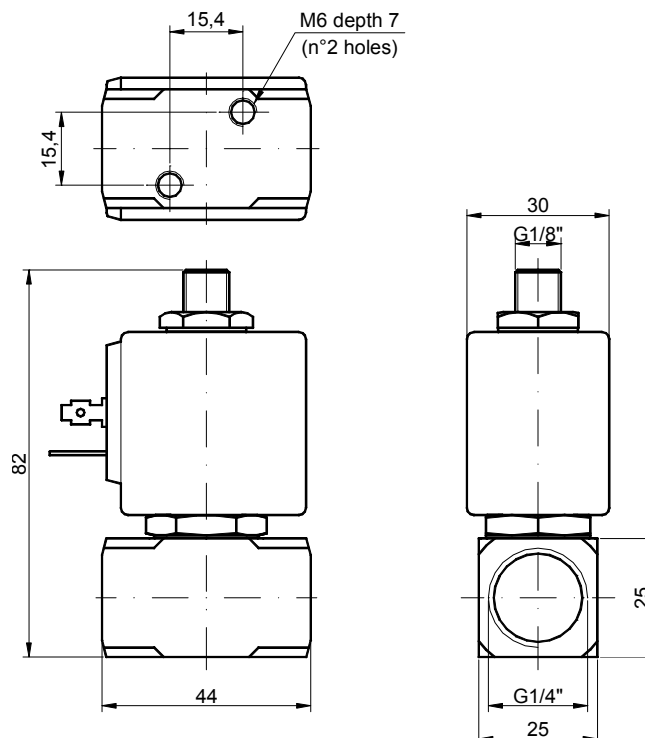

Weight = 0.36 Kg



## DESCRIPTION

Solenoid valve 3 way  
direct acting poppet type

## CONSTRUCTION

Body	Stainless steel
Armature tube	Stainless steel
Plunger and core	Stainless steel
Springs	Stainless steel
Seal material	NBR
	FPM
	EPDM

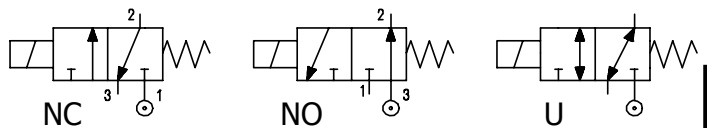

## FEATURES

- Maximum allowable pressure : maximum differential pressure +10%
- Maximum fluid viscosity 25cSt (mm<sup>2</sup>/s)
- Ambient temperature : with class F coil -10°C +55°C  
with class H coil -10°C +80°C
- Universal mounting position

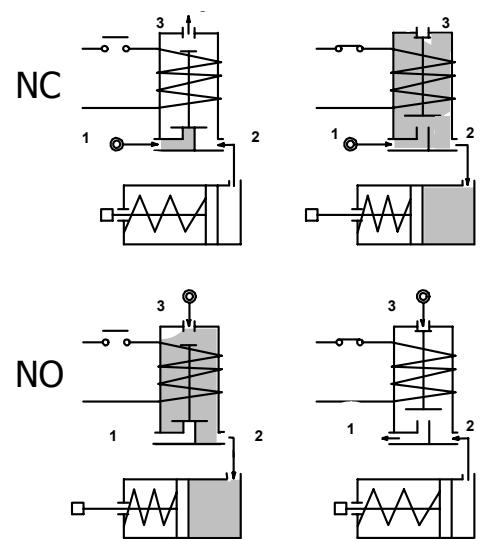

- OPTIONS :**
- Silver shading ring
  - Explosion proof coil according to ATEX - EExmII Series 7
  - Exhaust port with hosetail connection

CODE ① ②	Connection G ISO 228	Orifice mm		KV m <sup>3</sup> /h	Differential pressure bar			Nominal power			Coil		Seal ①	Temp. range °C
		Inlet	Exh.		Min	Max		AC Inrush	VA Holding	DC Watt	Series	Width		
						AC	DC							
<b>NC Normally closed</b>														
E311A.....12///.....	1/8"	1.2	1.5	0.04	0	15	15	12	8	6.5	3	22	NBR=B	-10 +90
E311A.....15///.....		1.5	1.5	0.06	0	10	10							
E311A.....20///.....		2	1.7	0.09	0	6	6							
<b>NO Normally open</b>														
E311A.....15/S/.....	1/8"	1.5	1.5	0.06	0	10	10	12	8	6.5	3	22	EPDM=E	<+140
E311A.....17/S/.....		1.7	2	0.07	0	6	6							
<b>U Universal</b>														
E311A.....15/G/.....	1/8"	1.5	1.5	0.06	0	6	6	12	8	6.5	3	22	FPM=V	-10 +130

- ① Seal
- ② Coil

Example: E311AV15///30B FPM seal Coil 24V 50/60Hz NC  
E311AB15/S/301 NBR seal Coil 24V DC NO

COIL	Alternating Current ~50/60Hz Volt							Direct Current Volt			Electrical connection	Connectors
	12	24	48	110	220 230	240	380	12	24	48		
Series 3 Width 22 Code ②	30A	30B	30C	30D	30E	30F	30G	300	301	302	DIN 46244	PG9 code 10348000

**DESCRIPTION**  
 Class F insulation  
 Voltage tolerance  
 AC +15% -10%  
 DC ± 10%  
 Protection class  
 IP65 with connector fitted  
 IP00 without connector  
 Continuous service ED100%

**OPTIONS**  
 Class H insulation  
 Cable attached  
 Special coil voltages  
 Special coil powers

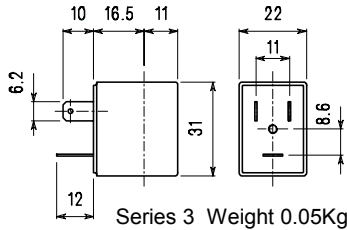

### SPARE PARTS LIST

1. Coil fixing nut
2. Coil
3. Plunger
4. Armature tube with core

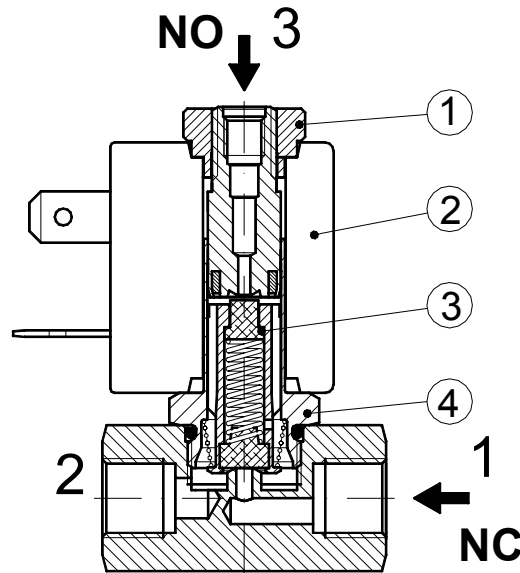

### OVERALL DIMENSION

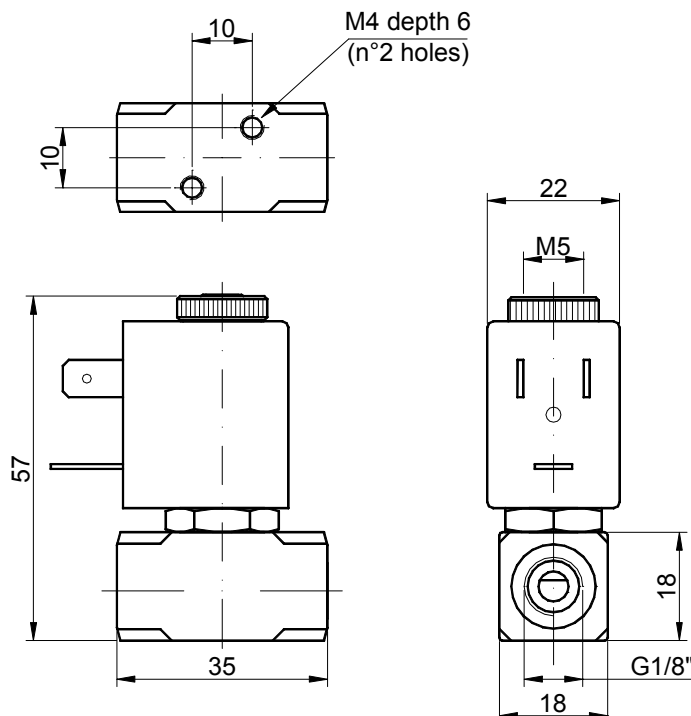



COILS	Alternating Current ~50/60Hz Volt							Direct Current Volt			Electrical connection	Connectors
	12	24	48	110	220 230	240	380	12	24	48		
Series 3 Width 22 Code ②	30A	30B	30C	30D	30E	30F	30G	300	301	302	DIN 46244	PG9 code 10348000

**DESCRIPTION**  
 Class F insulation  
 Voltage tolerance  
 AC +15% -10%  
 DC ± 10%  
 Protection class  
 IP65 with connector fitted  
 IP00 without connector  
 Continuous service ED100%

**OPTIONS**  
 Class H insulation  
 Cable attached  
 Special coil voltages  
 Special coil powers

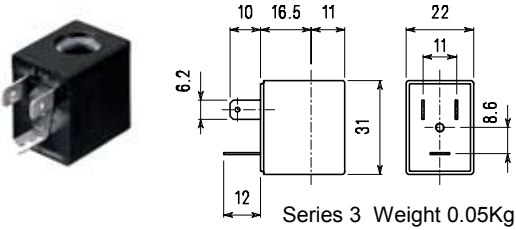

### SPARE PARTS LIST

1. Coil fixing nut
2. Coil
3. Plunger
4. Armature tube with core

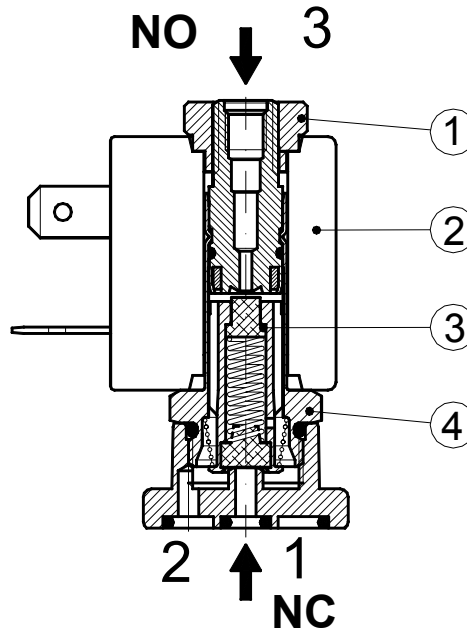

### OVERALL DIMENSION

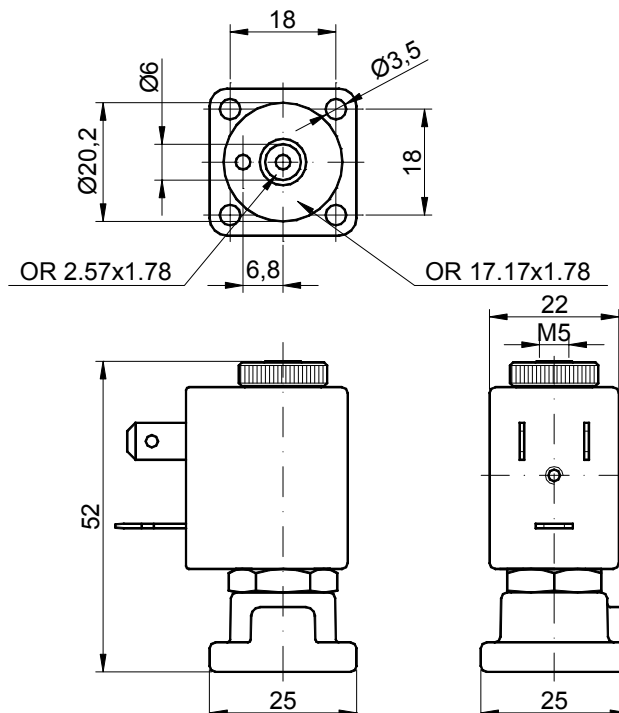

Weight = 0.12 Kg

**DESCRIPTION**

Solenoid valve 3 way normally open  
direct acting poppet type

**CONSTRUCTION**

Body	Brass
Armature tube	Brass
Plunger and core	Stainless steel
Springs	Stainless steel
Seal material	NBR
	FPM
	EPDM



**FEATURES**

Maximum allowable pressure : maximum differential pressure +10%

Maximum fluid viscosity 25cSt (mm<sup>2</sup>/s)

Ambient temperature : with class F coil -10°C +55°C  
with class H coil -10°C +80°C

Universal mounting position

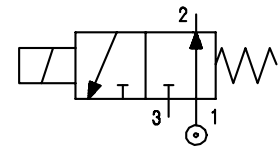

**3**

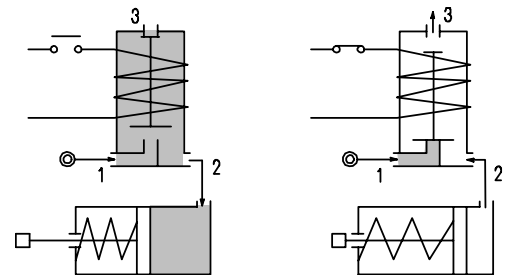

- OPTIONS :** Stainless steel armature tube  
Electroless nickel plating  
Explosion proof coil according to ATEX - EExmII Series 7  
Exhaust port with hosetail connection

CODE ① ②	Flange	Orifice mm		KV m <sup>3</sup> /h	Differential pressure bar			Nominal power			Coil		Seal ①	Temp. range °C
		Inlet	Exh.		Min	Max		AC Inrush	VA Holding	DC Watt	Series	Width		
						AC	DC							
E313X.....12///.....	Q 25	1.2	1.2	0.04	0	12	8	12	8	6.5	3	22	NBR=B EPDM=E FPM=V	-10 +90 <+140 -10 +130
E313X.....15///.....		1.5	1.2	0.06	0	9	6							

① Seal Example: E313XV15///30B FPM seal  
② Coil Coil 24V 50/60Hz

P.S. Solenoid valve supplied without fixing screws

COILS	Alternating Current ~50/60Hz Volt							Direct Current Volt			Electrical connection	Connectors
	12	24	48	110	220 230	240	380	12	24	48		
Series 3 Width 22 Code ②	30A	30B	30C	30D	30E	30F	30G	300	301	302	DIN 46244	PG9 code 10348000

**DESCRIPTION**  
 Class F insulation  
 Voltage tolerance  
 AC +15% -10%  
 DC ± 10%  
 Protection class  
 IP65 with connector fitted  
 IP00 without connector  
 Continuous service ED100%

**OPTIONS**  
 Class H insulation  
 Cable attached  
 Special coil voltages  
 Special coil powers

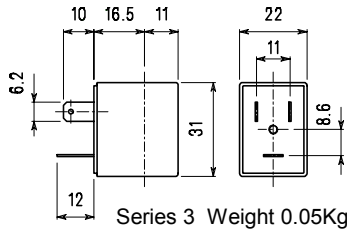

### SPARE PARTS LIST

1. Coil fixing nut
2. Coil
3. Plunger
4. Armature tube with core

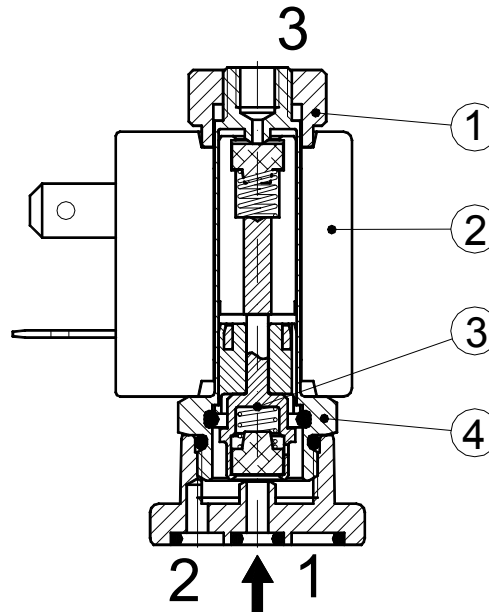

### OVERALL DIMENSION

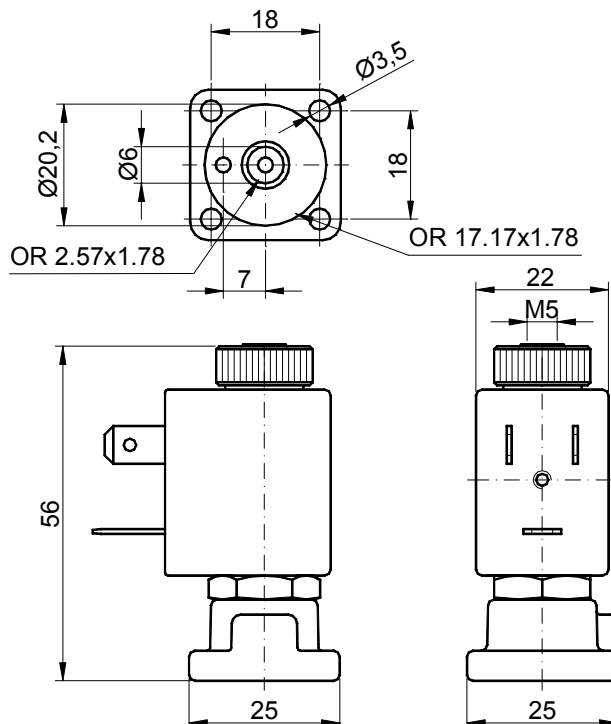

Weight = 0.12 Kg



COIL	Alternating Current ~50/60Hz Volt							Direct Current Volt			Electrical connection	Connectors
	12	24	48	110	220 230	240	380	12	24	48		
Series 2 Width 30 Code ②	20A	20B	20C	20D	20E	20F	20G	200	201	202	DIN 43650A	PG9 code 10349000

**DESCRIPTION**  
 Class F insulation  
 Voltage tolerance  
 AC +15% -10%  
 DC ± 10%  
 Protection class  
 IP65 with connector fitted  
 IP00 without connector  
 Continuous service ED100%

**OPTIONS**  
 Class H insulation  
 Cable attached  
 Special coil voltages  
 Special coil powers

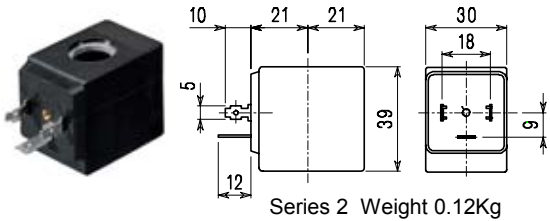

### SPARE PARTS LIST

1. Coil fixing nut
2. Coil
3. Plunger
4. Armature tube with core

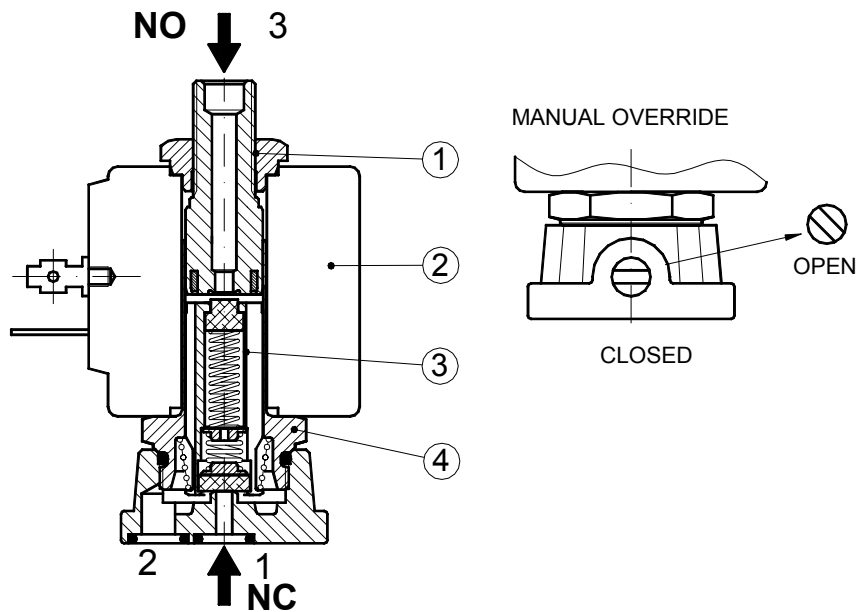

### OVERALL DIMENSION

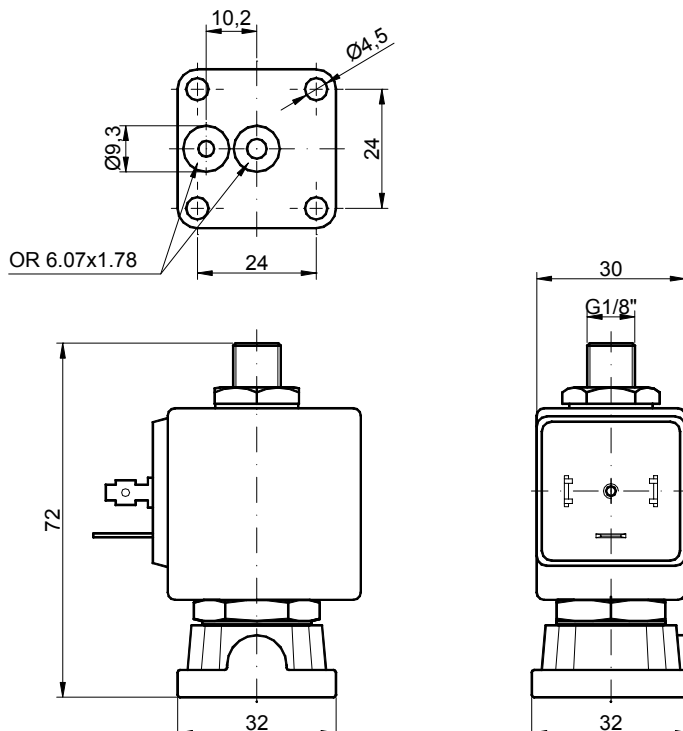

Weight = 0.25 Kg



### DESCRIPTION

Solenoid valve 3 way direct acting poppet type.  
 The balanced seal and the special construction allows a big flow.  
 The solenoid valve can be used as normally closed, normally open, mixer or diverter.

### CONSTRUCTION

Body	Anodized aluminium
Armature tube	Stainless steel
Plunger and core	Stainless steel
Springs	Stainless steel
Seal	FPM

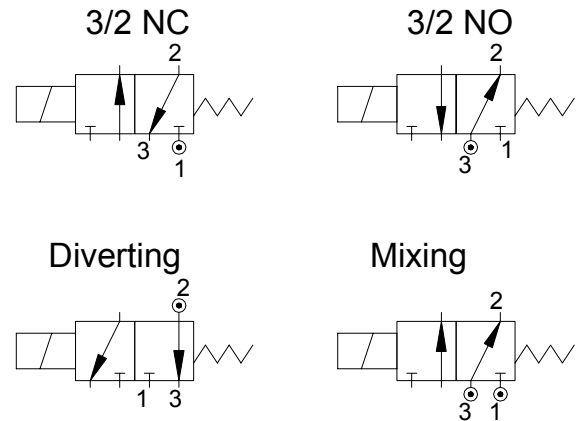

**3**

### FEATURES

Maximum allowable pressure : 15 bar  
 Maximum fluid viscosity 25cSt (mm<sup>2</sup>/s)  
 Ambient temperature : -10°C +80°C  
 Universal mounting position

CODE ②	Connection G ISO 228	Orifice mm	KV m <sup>3</sup> /h	Differential pressure bar			Nominal power			Coil		Seal	Temp. range °C
				Min	Max		AC Inrush	VA Holding	DC Watt	Series	Width		
					AC	DC							
<b>Universal</b>													
E320BV75///.....	1/4"	7.5	0.64	0	5	5	40	30	27	5	36	FPM=V	-10 +130
<b>Normally Closed</b>													
E321BV75///.....	1/4"	7.5	0.64	0	9	9	40	30	27	5	36	FPM=V	-10 +130
<b>Normally Open</b>													
E322BV75///.....	1/4"	7.5	0.64	0	9	9	40	30	27	5	36	FPM=V	-10 +130

② Coil

Example: E320BV75///52E Universal  
 FPM seal Coil 230V 50-60Hz

COILS	Alternating Current ~50/60Hz Volt							Direct Current Volt			Electrical connection	Connectors
	12	24	48	110	220 230	240	380	12	24	48		
Series 5 Width 36 Code ②	52A	52B	52C	52D	52E	52F	52G	520	521	522	DIN 43650A	PG11 code 10349001

**DESCRIPTION**  
 Class H insulation  
 Voltage tolerance  
 AC +15% -10%  
 DC ± 10%  
 Protection class  
 IP65 with connector fitted  
 IP00 without connector  
 Continuous service ED100%

**OPTIONS**  
 Cable attached  
 Special coil powers  
 Special coil voltages

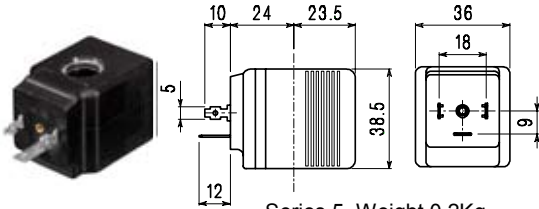

Series 5 Weight 0.2Kg

### SPARE PARTS LIST

1. Coil fixing nut
2. Coil
3. Armature tube with core

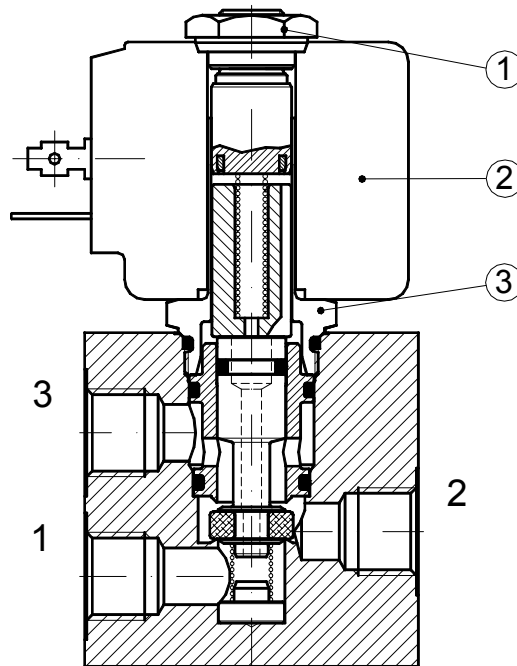

### OVERALL DIMENSION

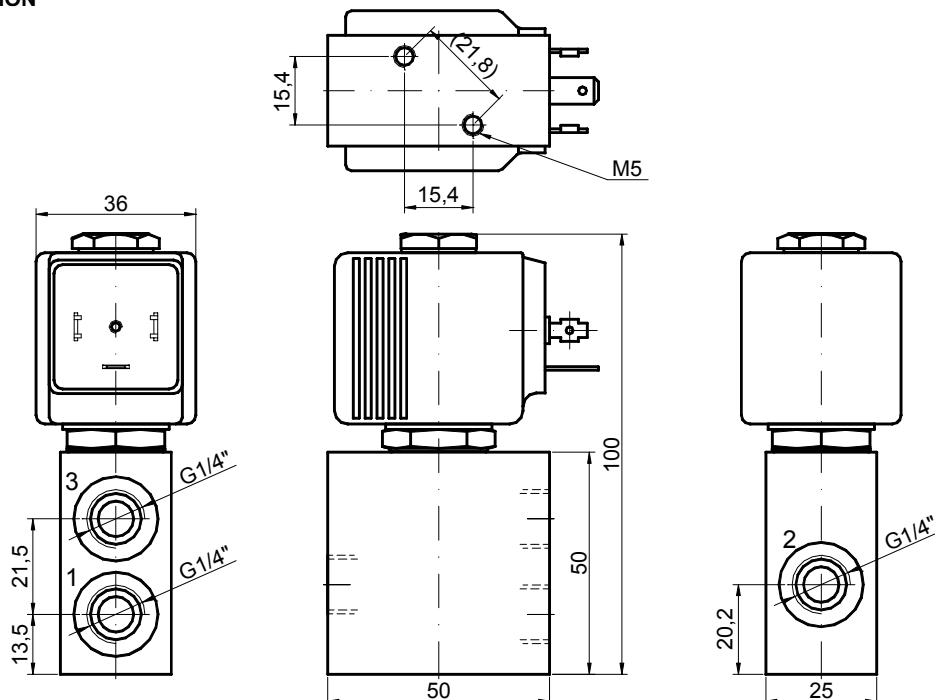

Weight = 0.43 Kg

**DESCRIPTION**

Solenoid valve 3 way direct acting with dry armature.  
No metal parts in contact with the media.

**CONSTRUCTION**

Body Acetal copolymer  
Seal material NBR



**FEATURES**

Maximum allowable pressure 0.5 bar  
Maximum fluid viscosity 25cSt (mm<sup>2</sup>/s)  
Ambient temperature: -10°C +45°C  
Maximum fluid temperature +50°C  
Universal mounting position

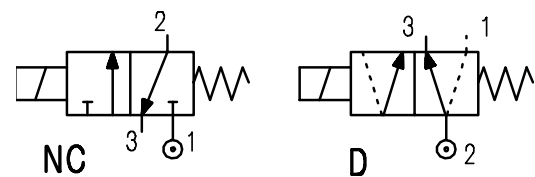

**3**

**ELECTRICAL OPERATING FEATURES**

Duty cycle : ED100%  
Insulation class : F  
Voltage tolerance : ±5%  
Protection class to IP65 with connector fitted

CODE	Hosetail connection	Orifice mm	KV m <sup>3</sup> /h	Differential pressure bar		Nominal power			Voltage		Connector
				Min	Max	Alternating current VA		Direct current Watt	AC	DC	
						Inrush	Holding				
				<b>NC Normally closed</b>		<b>D Diverting</b>					
① E330PB32/.../106620	Ø5.5	3.2	0.2	0	0.4	6.5	4.5	---	230	---	PG7 10348040
① D330PB32/.../111140	Ø5.5	3.2	0.2	0	0.4	---	---	4	---	12	
① D330PB32/.../111150	Ø5.5	3.2	0.2	0	0.4	---	---	4	---	24	

① Configuration

P.S. Solenoid valves and coils are not supplied separately

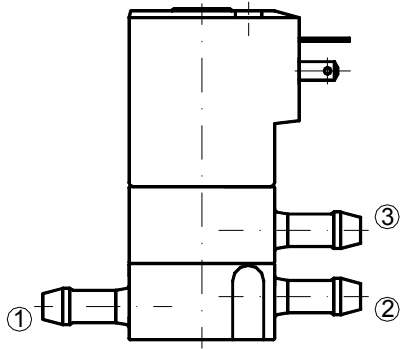

code /  
3/2 NC

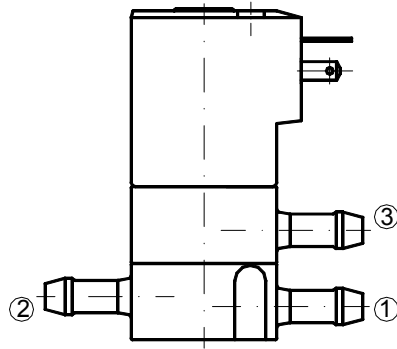

code D  
DIVERTING

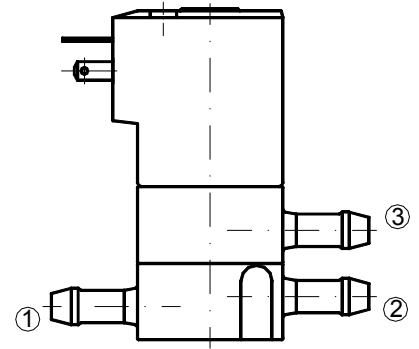

code R

### SPARE PARTS LIST

- 1. Coil
- 2. Diaphragm

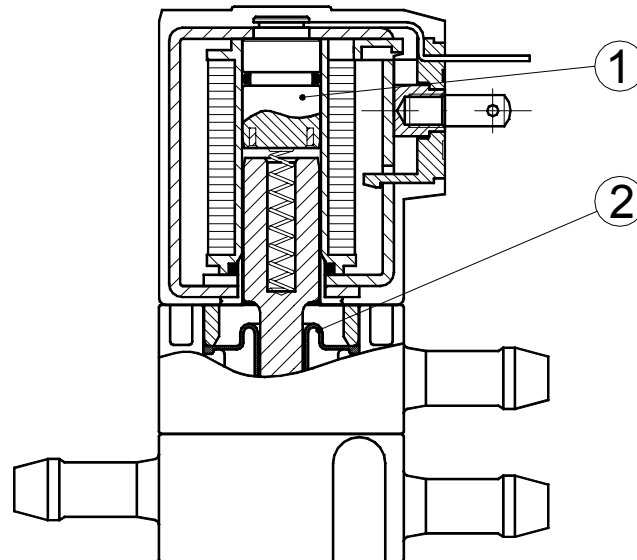

### OVERALL DIMENSION

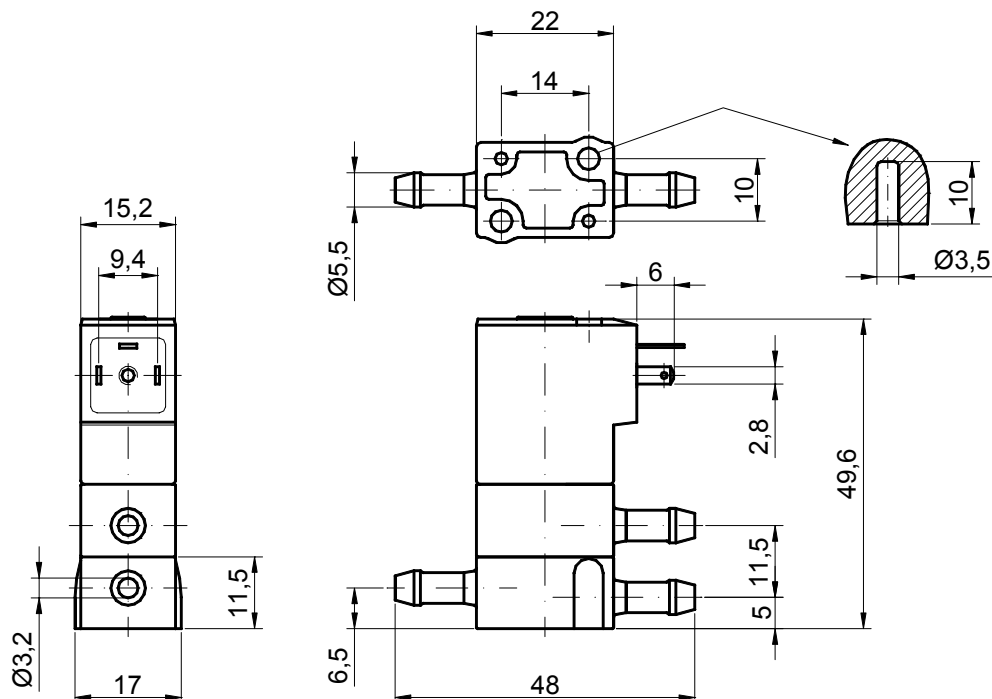

Weight = 0.04 Kg

### DESCRIPTION

Solenoid valve 3 way normally closed direct acting poppet type, suitable for food application and all compatible fluids.

### CONSTRUCTION

Body	Thermoplastic polymer: NSF, WRC, KTW, FDA certified
Armature tube	Brass chemically nickel plated
Plunger and core	Stainless steel
Springs	Stainless steel
Seal material	NBR food contact certified FPM food contact certified EPDM food contact certified



### FEATURES

- Maximum allowable pressure 10 bar
- Maximum fluid viscosity 25cSt (mm<sup>2</sup>/s)
- Ambient temperature : with class F coil -10°C +55°C  
with class H coil -10°C +80°C
- Universal mounting position

- OPTIONS :** Stainless steel armature tube  
Type N connection without nut

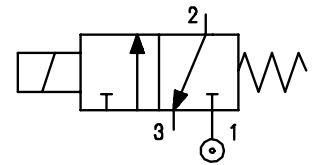

3

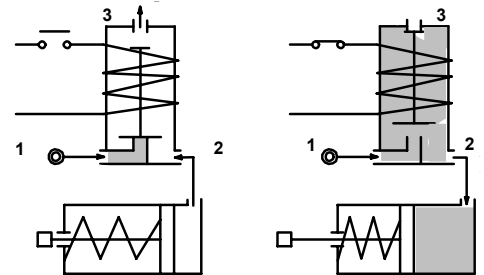

CONNECTIONS					
K	N	P	W ③	Y	Z
<b>SPIGGOT</b>	<b>G1/8" male thread with NUT for flexible and semiflexible pipes</b>	<b>HOSETAIL for flexible pipes</b>	<b>COMPRESSION for flexible and semiflexible pipes</b>	<b>PUSH IN for semiflexible pipes Øext.6</b>	<b>PUSH IN for semiflexible pipes Øext.4</b>

CODE ① ②	Connection *	Orifice mm	KV m³/h	Differential pressure bar			Nominal power			Coil		Seal ①	Temp. range ** °C
				Min	Max		AC Inrush	VA Holding	DC Watt	Series	Width		
					AC	DC							
E335*.....15///.....	K-N-P-W-Y-Z	1.5	0.06	0	9	9	12	8	6.5	3	22	NBR=A EPDM=E FPM=V	-10 +90 <+140 -10 +130

- ① Seal
  - ② Coil
  - ③ Only for connection "W"
- Example: E335KA20///30B NBR seal SPIGGOT connection  
Coil 24V 50/60Hz  
E335W..../1/....

\*\* The temperature range is related to the material of the seals (NBR, EPDM, FPM), and the valves' body. Please contact us concerning the temperature range referred to the different types of connection.

COILS	Alternating current ~50/60Hz Volt							Direct Current Volt			Electrical connection	Connectors
	12	24	48	110	220 230	240	380	12	24	48		
Series 3 Width 22 Code ②	30A	30B	30C	30D	30E	30F	30G	300	301	302	DIN 46244	PG9 code 10348000

**DESCRIPTION**  
 Class F insulation  
 Voltage tolerance  
 AC +15% -10%  
 DC ± 10%  
 Protection class  
 IP65 with connector fitted  
 IP00 without connector  
 Continuous service ED100%

**OPTIONS**  
 Class H insulation  
 Cable attached  
 Special coil power  
 Special coil voltages

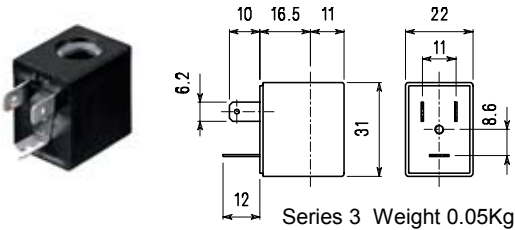

### SPARE PARTS LIST

1. Coil fixing nut
2. Coil
3. Plunger
4. Armature tube with core

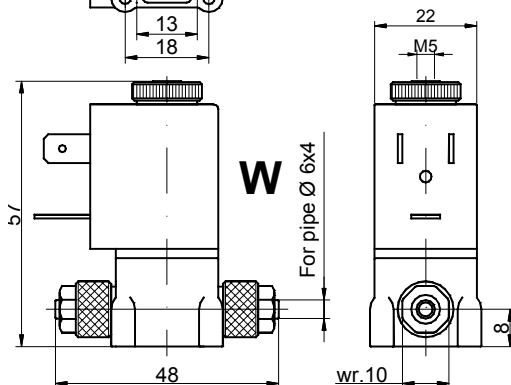
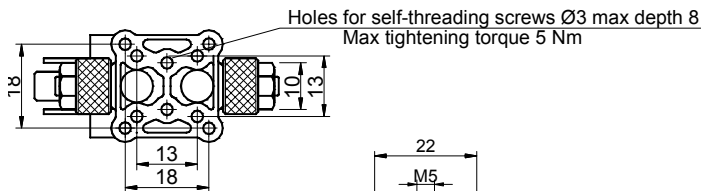
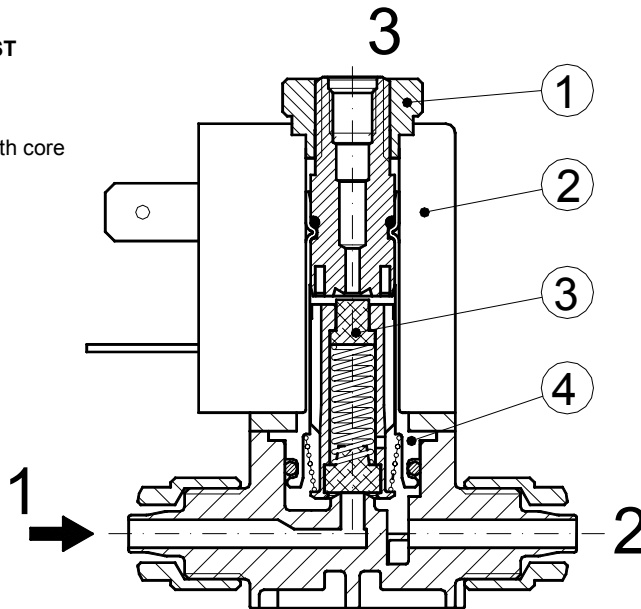

Nut Max torque 2 Nm

Weight = 0.10 Kg

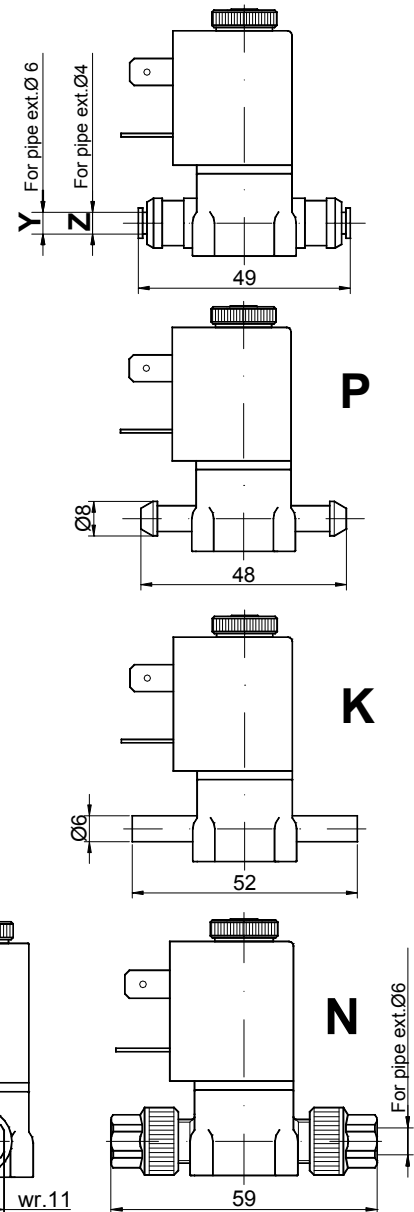

Screw the nut with wrench 11 up to the sliding on the hexagon (TORQUE LIMITING DEVICE)

### DESCRIPTION

Solenoid valve 3 way normally closed direct acting poppet type, suitable for food application and all compatible fluids.

### CONSTRUCTION

Body	Thermoplastic polymer: NSF, WRC, KTW, FDA certified
Armature tube	Brass
Plunger and core	Stainless steel
Springs	Stainless steel
Seal material	NBR food contact certified FPM food contact certified EPDM food contact certified



### FEATURES

Maximum allowable pressure 10 bar  
 Maximum fluid viscosity 25cSt (mm<sup>2</sup>/s)  
 Ambient temperature : with class F coil -10°C +55°C  
 with class H coil H -10°C +80°C  
 Universal mounting position

**OPTIONS :** Stainless steel armature tube  
 Chemically nickel-plated armature tube  
 Type N connection without nut

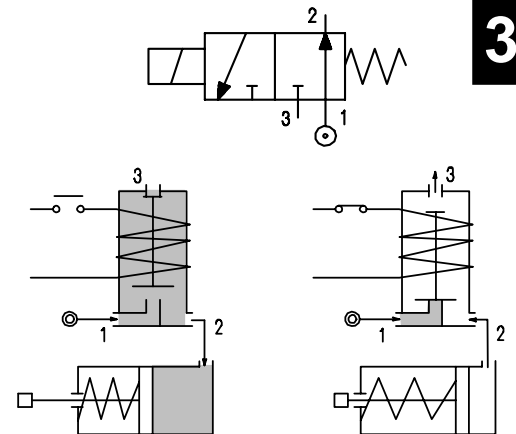

**3**

CONNECTIONS					
K	N	P	W ③	Y	Z
<b>SPIGGOT</b>	<b>G1/8" male thread with NUT for flexible and semiflexible pipes</b>	<b>HOSETAIL for flexible pipes</b>	<b>COMPRESSION for flexible and semiflexible pipes</b>	<b>PUSH IN for semiflexible pipes</b> Øext.6	<b>PUSH IN for semiflexible pipes</b> Øext.4

CODE ① ②	Connections *	Orifice mm	KV m³/h	Differential pressure bar			Nominal power			Coil		Seal ①	Temperature range ** °C
				Min	Max		AC Inrush	VA Holding	DC Watt	Series	Width		
					AC	DC							
E337*.....15///.....	K-N-P-W-Y-Z	1.5	0.06	0	9	6	12	8	6.5	3	22	NBR=A EPDM=E FPM=V	-10 +90 <+140 -10 +130

- ① Seal Es. E337KA20///30B NBR seal Spigot connection
- ② Coil Coil 24V 50/60Hz
- ③ Only for connection "W" E337W..../1/....

\*\* The temperature range is related to the material of the seals (NBR, EPDM, FPM), and the valves' body. Please contact us concerning the temperature range referred to the different types of connection.

COILS	Alternating Current ~50/60Hz Volt							Direct current Volt			Electrical connection	Connectors
	12	24	48	110	220 230	240	380	12	24	48		
Series 3 Width 22 Code ②	30A	30B	30C	30D	30E	30F	30G	300	301	302	DIN 46244	PG9 code 10348000

**DESCRIPTION**  
 Class F insulation  
 Voltage tolerance  
 CA +15% -10%  
 CC ± 10%  
 Protection class  
 IP65 with connector fitted  
 IP00 without connector  
 Continuous service ED100%

**OPTIONS**  
 Class H insulation  
 Cable attached  
 Special coil powers  
 Special coil voltages

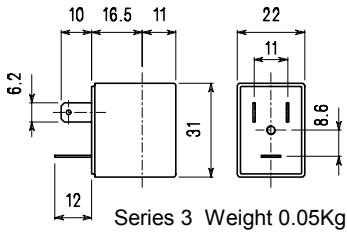

### SPARE PARTS LIST

1. Coil fixing nut
2. Coil
3. Seal assembly
4. Armature tube

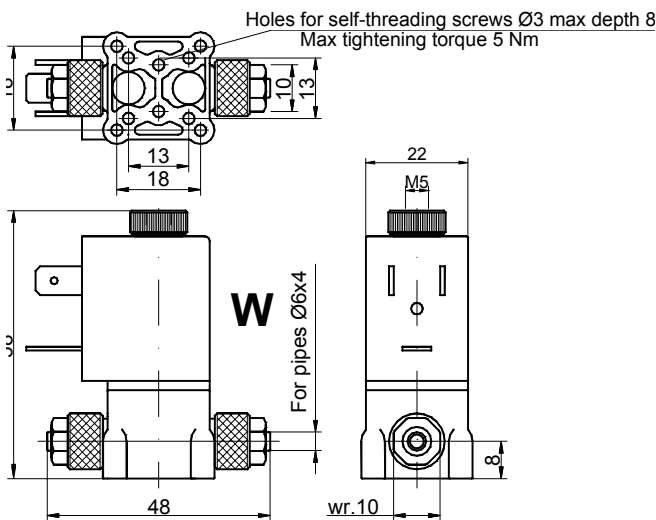
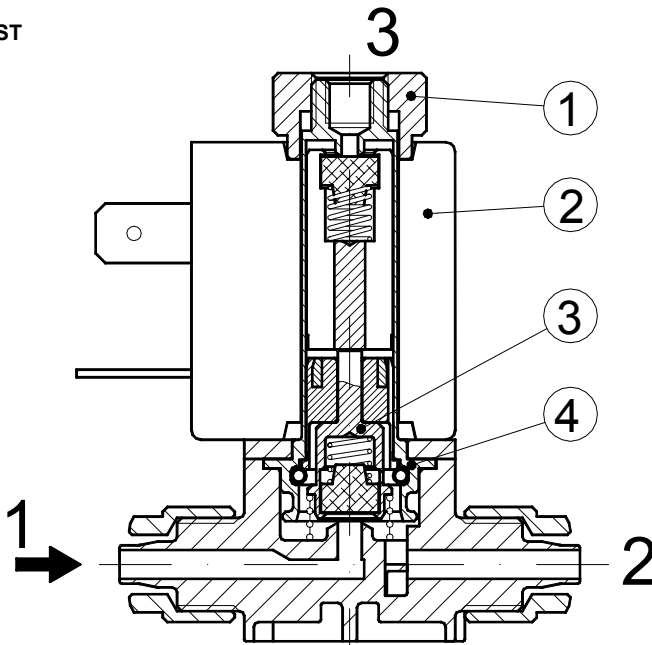

Weight = 0.10 Kg

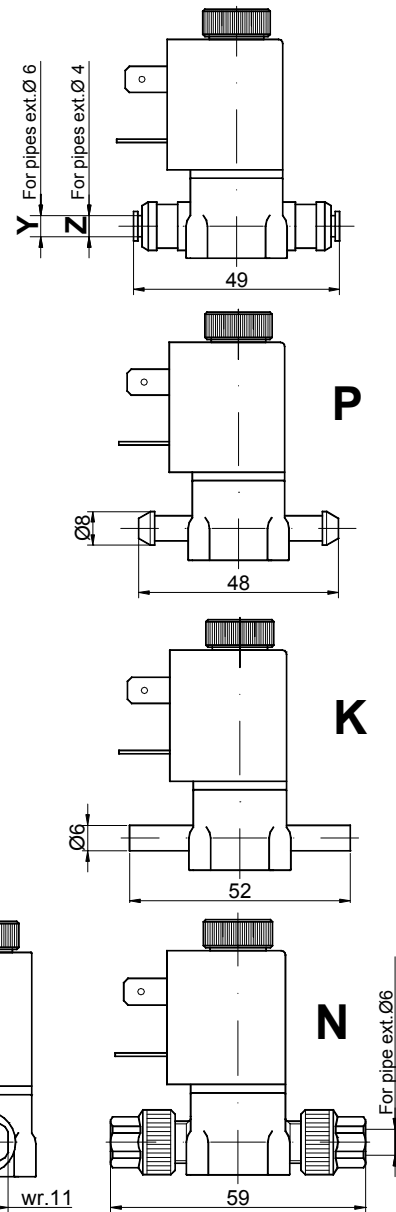

Screw the nut with wrench 11 up to the sliding on the hexagon (TORQUE LIMITING DEVICE)



## DESCRIPTION

Solenoid valve 3 way  
direct acting poppet type

## CONSTRUCTION

Body Acetal copolymer  
Internal parts Acetal copolymer – Stainless steel  
Seal material NBR



## FEATURES

Fixing method : M3 screws  
Max torque 0.5Nm  
Universal mounting position  
Fluid temperature : 50°C max  
Ambient temperature : -15°C +50°C  
Fluid : Air, Neutral gases  
Response time : 10-15ms  
Manual override : Enclosed bi-stable function

3/2 NC

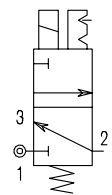

3/2 NO

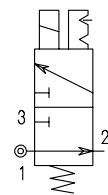

3/2 U

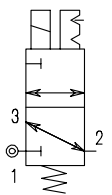

3

## ELECTRICAL OPERATING FEATURES

Duty cycle : ED100%  
Insulation class : F (155°C)  
Voltage tolerance : ±10%  
Protection class : Cables IP65  
Fast-on IP00  
With connector fitted IP65  
Electrical connection : Cables (L=300mm)  
AMP 2.8x0.5  
DIN 43650/C

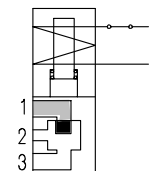
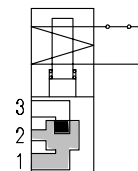
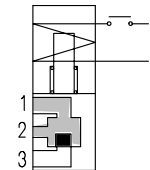
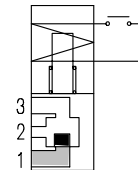

Connection	Orifice mm		Pa=6bar NI/1' Nominal rate Δp=1bar	Differential pressure bar		Power consumption at 20°C			CODE	
	1→2	2→3		Min	Max	Alternating current VA		Direct current Watt	Alternating current	Direct current
<b>NC Normally closed</b>										
Flange	0.8	0.9	23	0	10	---	---	1.5	E340XB08	D340XB08
Flange	1.2	1.3	29	0	10	3.6	2.5	2.5	E340XB12	D340XB12
Flange	1.5	1.6	43	0	6	3.6	2.5	2.5	E340XB15	D340XB15
<b>NA Normally open</b>										
Flange	1	1.2	26	0	8	3.6	2.5	2.5	E341XB10	D341XB10
Flange	1	1.2	26	0	8	3.6	2.5	2.5	E343XB10	D343XB10
<b>U Universal</b>										
Flange	1.5	1.6	43	0	2.5	3.6	2.5	2.5	E342XB15	D342XB15

## COIL CODE

VOLTAGE	AMP 2.8 x 0.5			DIN 43650 C form			CABLE		
	50/60Hz	1.5WDC	2.5WDC	50/60Hz	1.5WDC	2.5WDC	50/60Hz	1.5WDC	2.5WDC
12	---	106970	106950	---	109020	109040	---	107010	106990
24	107030	106980	106960	108990	109030	109050	107040	107020	107000
110	107060	---	---	109000	---	---	---	---	---
220/230	107050	---	---	109010	---	---	---	---	---

P.S. 1,5W power available on Ø0.8 orifice only

**CONNECTIONS**

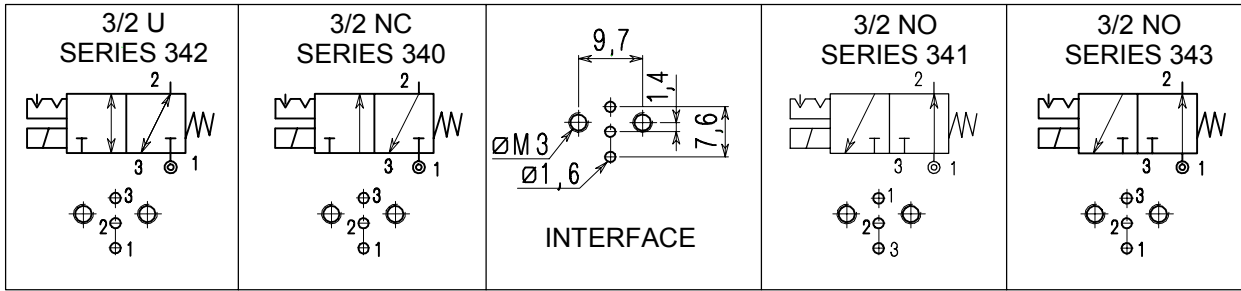

**OVERALL DIMENSIONS**

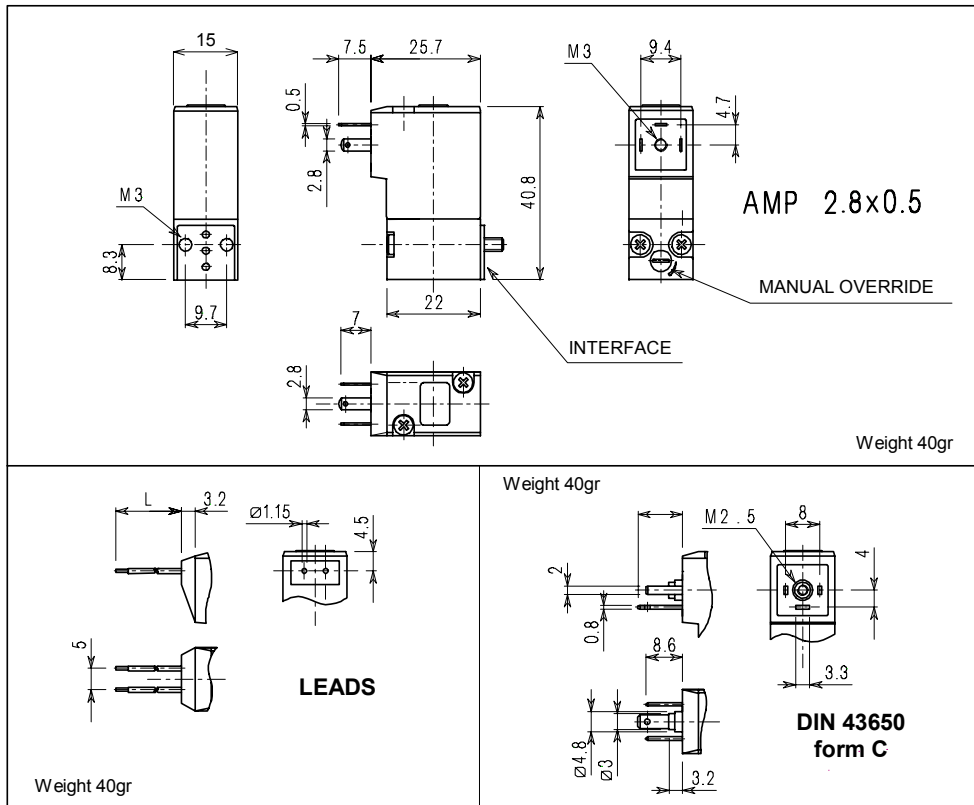

**TYPE NUMBER COMPOSITION**

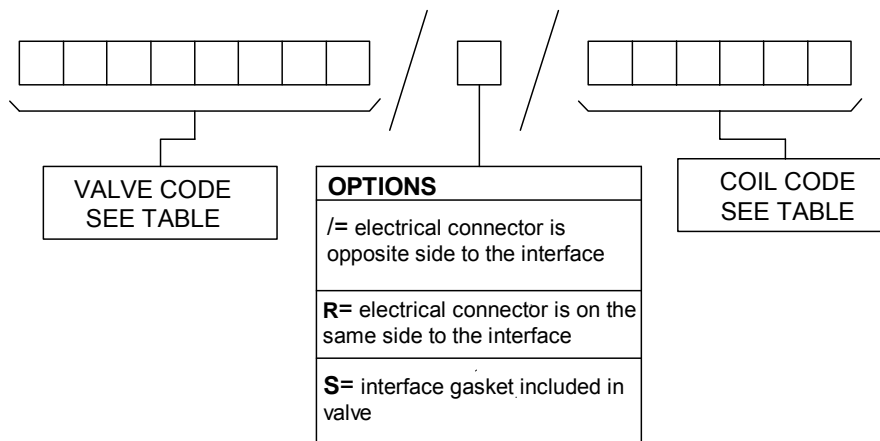

Example :D340XB12///106960 3way NC-24V DC 2,5W. Electrical connection AMP2.8x0.5 is on the opposite side of the interface.

## DESCRIPTION

Solenoid valve 3 way  
Direct acting poppet type

## CONSTRUCTION

Body Acetal copolymer  
Internal parts Acetal copolymer – Stainless steel  
Seal material NBR



## FEATURES

Fixing method : M2.5 screws  
Max torque 0.5Nm  
Universal mounting position  
Fluid temperature : 50°C max  
Ambient temperature : -15°C +50°C  
Fluid : Air, Neutral gases  
Response time : 10-15ms  
Manual override : Enclosed bi-stable function

3/2 NC

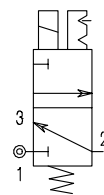

3/2 NO

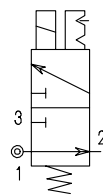

3/2 U

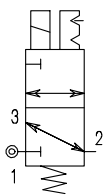

3

## ELECTRICAL OPERATING FEATURES

Duty cycle : ED100%  
Insulation class : F (155°C)  
Voltage tolerance : ±10%  
Protection class : Cables IP65  
Fast-on IP00  
With connector fitted IP65  
Electrical connection : Cables (L=300mm)  
AMP 2.8x0.5  
DIN 43650/C

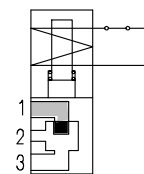
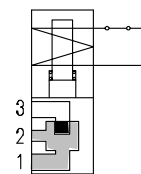
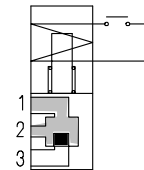
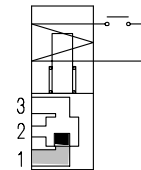

Connection	Orifice mm		Pa=6bar NI/1' Nominal rate Δp=1bar	Differential pressure bar		Power consumption at 20°C			CODE	
	1→2	2→3		Min	Max	Alternating current VA		Direct current Watt	Alternating current	Direct current
<b>NC Normally closed</b>										
Flange	0.8	0.9	23	0	10	---	---	1.5	E345XB08	D345XB08
Flange	1.2	1.3	29	0	10	3.6	2.5	2.5	E345XB12	D345XB12
Flange	1.5	1.6	43	0	6	3.6	2.5	2.5	E345XB15	D345XB15
<b>NO Normally open</b>										
Flange	1	1.2	26	0	8	3.6	2.5	2.5	E346XB10	D346XB10
<b>U Universal</b>										
Flange	1.5	1.6	43	0	2.5	3.6	2.5	2.5	E347XB15	D347XB15

## COIL CODE

VOLTAGE	AMP 2.8 x 0.5			DIN 43650 C form			CABLE		
	50/60Hz	1.5WDC	2.5WDC	50/60Hz	1.5WDC	2.5WDC	50/60Hz	1.5WDC	2.5WDC
12	---	106970	106950	---	109020	109040	---	107010	106990
24	107030	106980	106960	108990	109030	109050	107040	107020	107000
110	107060	---	---	109000	---	---	---	---	---
220/230	107050	---	---	109010	---	---	---	---	---

P.S. 1,5W power available on Ø0.8 orifice only

**CONNECTION**

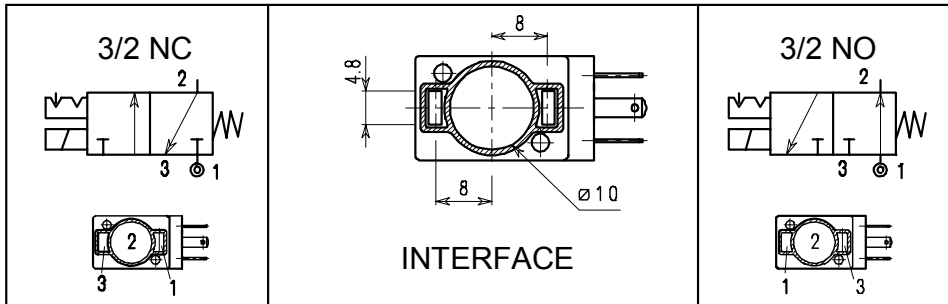

**OVERALL DIMENSIONS**

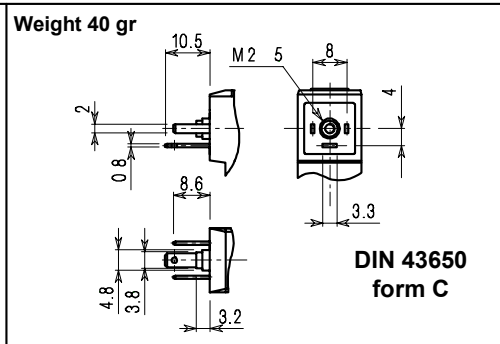
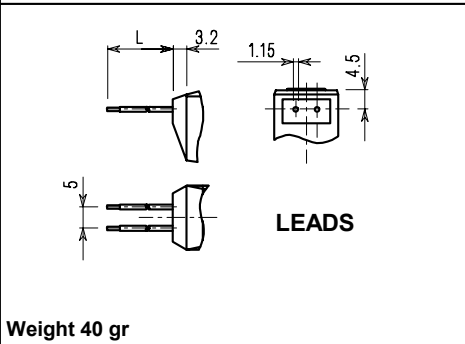
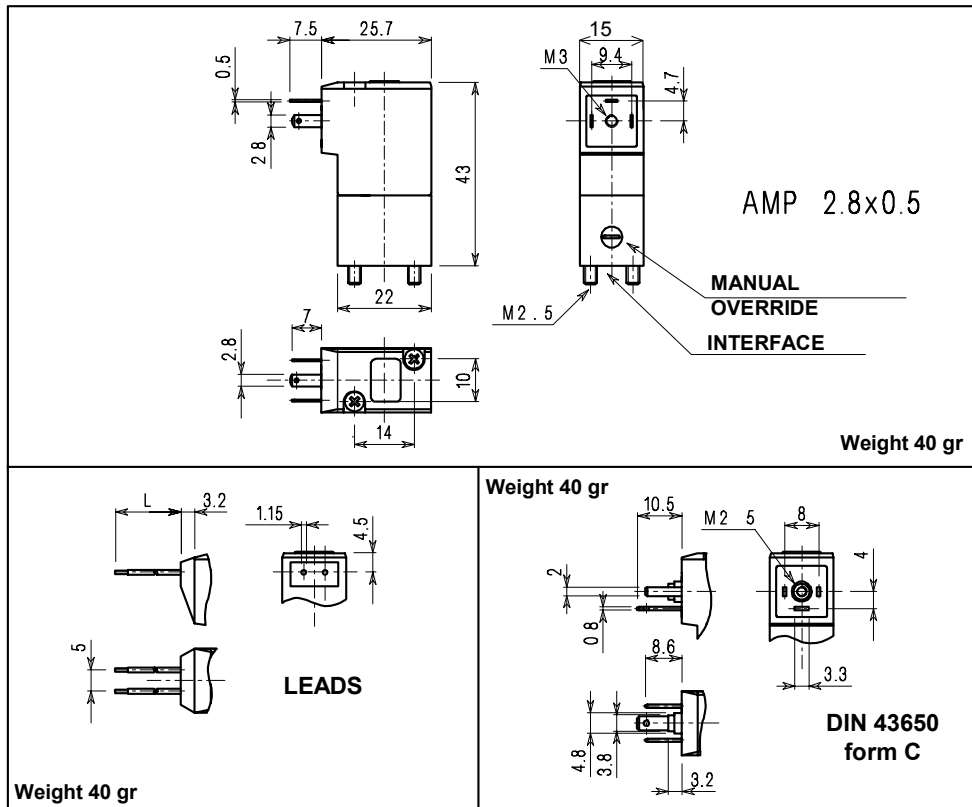

**TYPE NUMBER COMPOSITION**

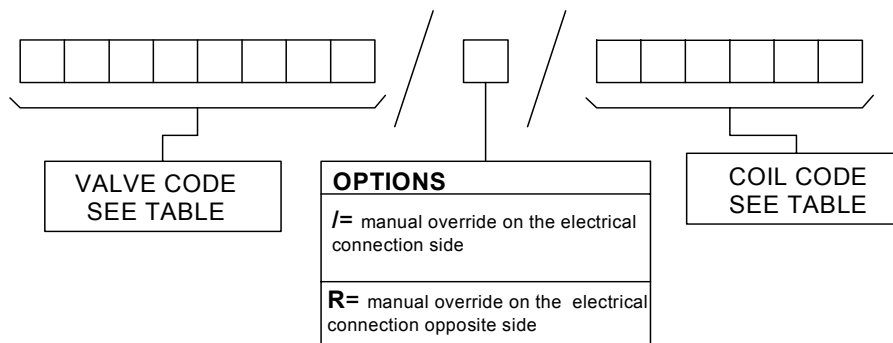

Example: D345XB12///10960 3 way NC-24VDC 2,5W. Electrical connection AMP2.8x0.5 is on the opposite side of the manual override.

**DESCRIPTION**

Solenoid valve 3 way normally closed  
direct acting poppet type for modular construction

**CONSTRUCTION**

Body	Die-cast aluminium
Armature tube	Brass
Plunger and core	Stainless steel
Springs	Stainless steel
Seal material	NBR
	FPM
	EPDM



**FEATURES**

Media : Air, Neutral gases  
Ambient temperature : with class F coil -10°C +55°C  
with class H coil -10°C +80°C  
Universal mounting position

**OPTIONS :** Manual override  
Stainless steel armature tube  
Electroless nickel plating  
Explosion proof coil according to ATEX - EExmII Series 7  
Wet proof coil fixing nut

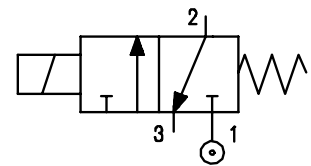

**3**

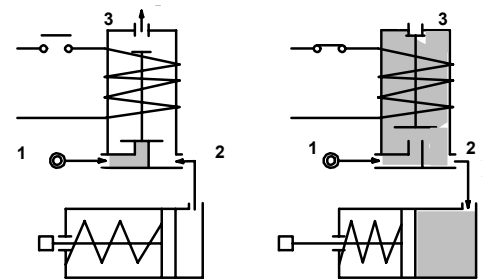

**NOTE: This valve ISN'T standard. Contact the manufacturer for any question**

CODE ① ②	Connection	Orifice mm		KV m³/h	Differential pressure bar			Nominal power			Coil		Seal ①	Temp. range °C
		Inlet	Exh.		Min	Max		AC Inrush	VA Holding	DC Watt	Series	Width		
						AC	DC							
E350B.....15///.....	G1/4"	1.5	1.5	0.06	0	10	10	12	8	6.5	3	22	NBR=B EPDM=E FPM=V	-10 +90  +140 -10 +130
E350B.....17///.....		1.7	1.7	0.08	0	8	8	12	8	6.5	3	22		
E350B.....17///.....		1.7	1.7	0.08	0	10	10	15	11	5	4	30		
E350M.....15///.....	M12x1.5	1.5	1.5	0.06	0	10	10	12	8	6.5	3	22	EPDM=E FPM=V	+140 -10 +130
E350M.....17///.....		1.7	1.7	0.08	0	8	8	12	8	6.5	3	22		
E350M.....17///.....		1.7	1.7	0.08	0	10	10	15	11	5	4	30		

- ① Seal
- ② Coil

Example: E350MV17///30B FPM seal M12x1.5 connection  
Coil 24V 50/60Hz

COILS	Alternating Current ~50/60Hz Volt							Direct Current Volt			Electrical connection	Connectors
	12	24	48	110	220 230	240	380	12	24	48		
Series 3 Width 22 Code ②	30A	30B	30C	30D	30E	30F	30G	300	301	302	DIN 46244	PG9 code 10348000
Series 4 Width 30 Code ②	40A	40B	40C	40D	40E	40F	40G	400	401	402	DIN 43650A	PG9 code 10349000

**DESCRIPTION**  
 Class F insulation  
 Voltage tolerance  
 AC +15% -10%  
 DC ± 10%  
 Protection class  
 IP65 with connector fitted  
 IP00 without connector  
 Continuous service ED100%

**OPTIONS**  
 Class H insulation  
 Cable attached  
 Special coil voltage  
 Special coil powers

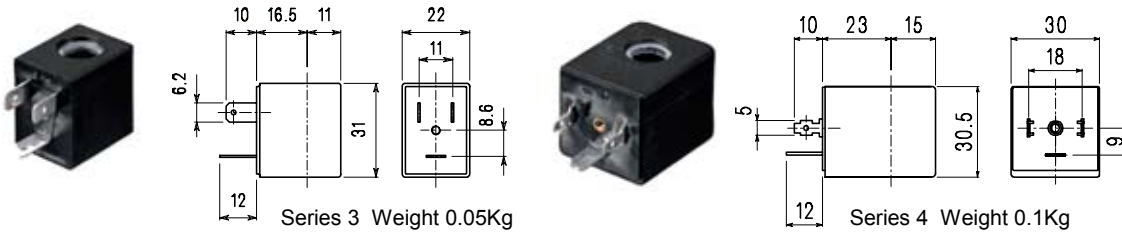

**SPARE PARTS LIST**

- 1. Coil fixing nut
- 2. Coil
- 3. Plunger
- 4. Armature tube with core

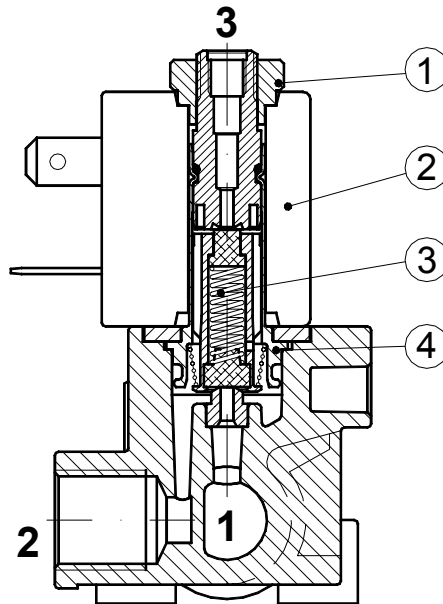

**MANUAL OVERRIDE**

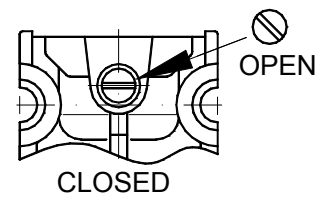

**OVERALL DIMENSION**

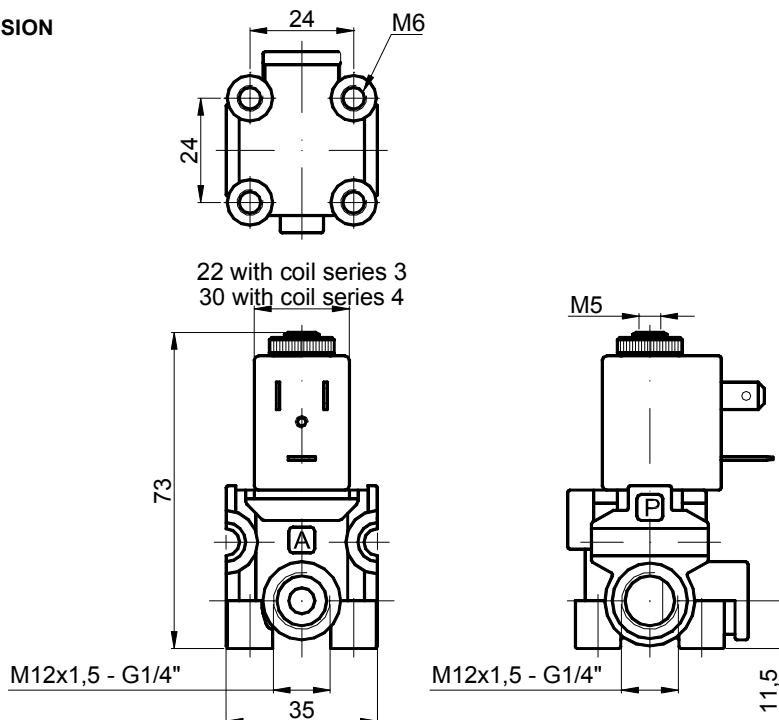

Weight with coil series 3 = 0.14 Kg  
 Weight with coil series 4 = 0.19 Kg

**DESCRIPTION**

Solenoid valve 3 way normally open  
direct acting poppet type for modular construction

**CONSTRUCTION**

Body	Die-cast aluminium
Armature tube	Brass
Plunger and core	Stainless steel
Springs	Stainless steel
Seal material	NBR
	FPM
	EPDM



**FEATURES**

Media : Air, Natural gases  
Ambient temperature : with class F coil -10°C +55°C  
with class H coil -10°C +80°C  
Universal mounting position

**OPTIONS :** Electroless nickel plating  
Explosion proof coil according to ATEX - EExmII Series 7  
Wet proof coil fixing nut

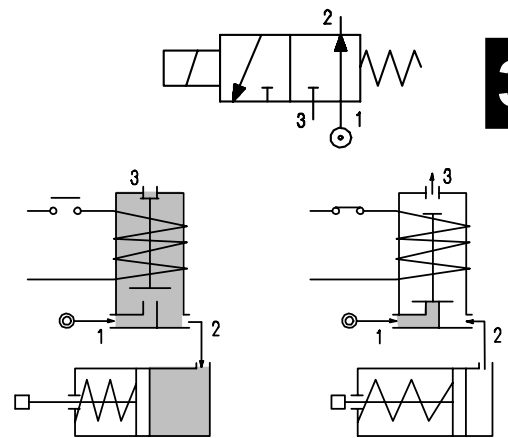

**NOTE: This valve ISN'T standard. Contact the manufacturer for any question**

CODE ① ②	Connection	Orifice mm		KV m³/h	Differential pressure bar			Nominal power			Coil		Seal ①	Temp. range °C		
		Inlet	Exh.		Min	Max		AC Inrush	VA Holding	DC Watt	Series	Width				
						AC	DC									
E351B.....15///.....	G1/4"	1.5	1.5	0.06	0	10	10	12	8	6.5	3	22	NBR=B	-10 +90		
E351B.....17///.....		1.7	1.7	0.08	0	8	8	12	8	6.5	3	22				
E351B.....17///.....		1.7	1.7	0.08	0	10	10	15	11	5	4	30			EPDM=E	<+140
E351M.....15///.....	M12x1.5	1.5	1.5	0.06	0	10	10	12	8	6.5	3	22	FPM=V	-10 +130		
E351M.....17///.....		1.7	1.7	0.08	0	8	8	12	8	6.5	3	22				
E351M.....17///.....		1.7	1.7	0.08	0	10	10	15	11	5	4	30				

- ① Seal
- ② Coil

Example: E351MV17///301 FPM seal M12x1.5 connection  
Coil 24V DC

COIL	Alternating current ~50/60Hz Volt							Direct current Volt			Electrical connection	Connectors
	12	24	48	110	220 230	240	380	12	24	48		
Series 3 Width 22 Code ②	30A	30B	30C	30D	30E	30F	30G	300	301	302	DIN 46244	PG9 code 10348000
Series 4 Width 30 Code ②	40A	40B	40C	40D	40E	40F	40G	400	401	402	DIN 43650A	PG9 code 10349000

**DESCRIPTION**  
 Class F insulation  
 Voltage tolerance  
 AC +15% -10%  
 DC ± 10%  
 Protection class  
 IP65 with connector fitted  
 IP00 without connector  
 Continuous service ED100%

**OPTIONS**  
 Class H insulation  
 Cable attached  
 Special coil powers  
 Special coil voltages

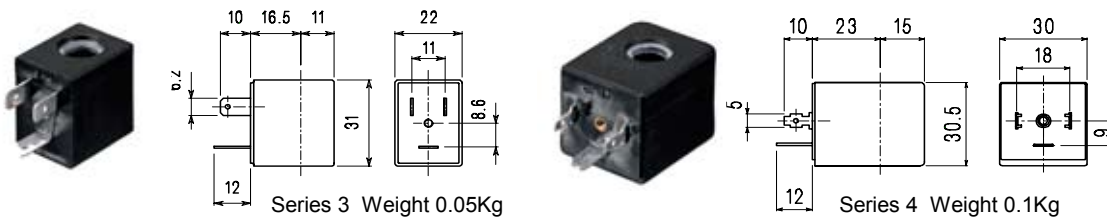

### SPARE PARTS LIST

1. Coil fixing nut
2. Coil
3. Seal assembly
4. Armature tube

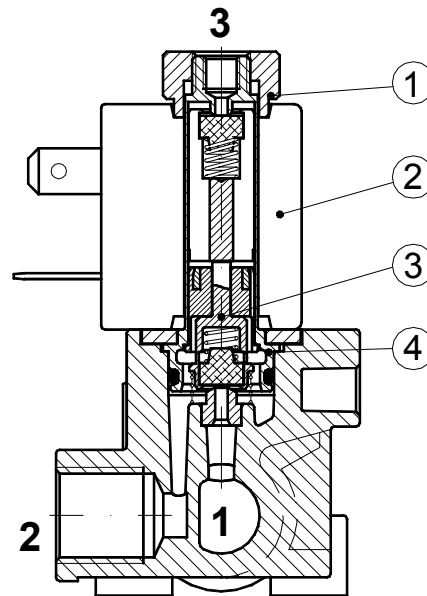

### OVERALL DIMENSION

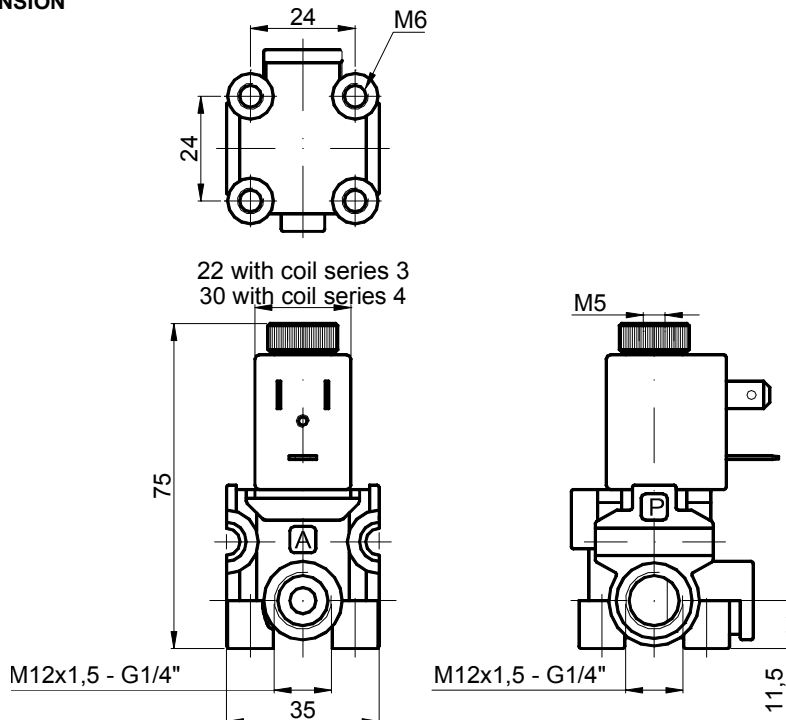

Weight with coil series 3 = 0.14 Kg  
 Weight with coil series 4 = 0.19 Kg



**DESCRIPTION**

Solenoid valve 2 way normally closed with servo-assisted diaphragm

**CONSTRUCTION**

Body and cover	Brass
Armature tube	Stainless steel
Plunger and core	Stainless steel
Springs	Stainless steel
Seal material	NBR FPM EPDM



**FEATURES**

- Minimum differential pressure 0.15 bar
- Maximum allowable pressure\* : 25 bar
- Maximum fluid viscosity 25cSt (mm<sup>2</sup>/s)
- Ambient temperature : with class F coil -10°C +55°C  
with class H coil -10°C +80°C
- Preferred mounting position with vertical coil above

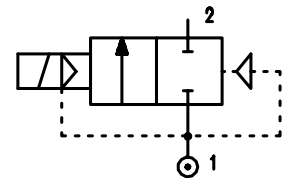

**OPTIONS**

- :Manual override
- Electroless nickel plating
- Explosion proof coil according to ATEX - EExmII Series 7
- Version with slow closing diaphragm
- Version for vacuum applications (air/gas)
- Version for use with oxygen

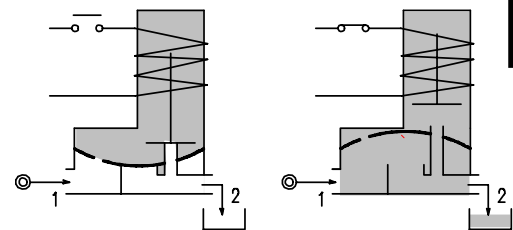

4

Certified versions:



CODE ① ②	Connection G ISO 228	Orifice mm	KV m <sup>3</sup> /h	Differential pressure bar			Nominal power			Coil		Seal ①	Temp. range °C
				Min	Max		AC Inrush	VA Holding	DC Watt	Series	Width		
					AC	DC							
E107B...10///...	1/4"	10	1.5	0.15	15	15	12	8	6.5	3	22	NBR=B EPDM=E FPM=V	-10 +90 <+140 -10 +130
E107C...10///...	3/8"	10	1.7	0.15	15	15							
E107C...12///...	3/8"	12	2.2	0.15	15	15							
E107D...12///...	1/2"	12	2.5	0.15	15	15							
E107E...18///...	3/4"	18	5.5	0.15	13	13							
E107F...25///...	1"	24	10.2	0.15	10	10							
E107G...30///...	1 1/4"	30	15	0.15	10	10	15	11	5	4	30	NBR=B	-10 +90
③ E107C...12/W/...	3/8"	12	2.2	0.5	25	25							
③ E107D...12/W/...	1/2"	12	2.5	0.5	25	25							

- ① Seal Example: E107DB12///301 NBR seal
- ② Coil Coil 24V DC
- ③ Reinforced diaphragm

\* REMARK: The maximum allowable pressure PS for steam is 2,5bar (gauge pressure)

COILS	Alternating Current ~50/60Hz Volt							Direct Current Volt			Electrical connection	Connectors
	12	24	48	110	220 230	240	380	12	24	48		
Series 3 Width 22 Code ②	30A	30B	30C	30D	30E	30F	30G	300	301	302	DIN 46244	PG9 code 10348000
Series 4 Width 30 Code ②	40A	40B	40C	40D	40E	40F	40G	400	401	402	DIN 43650A	PG9 code 10349000

**DESCRIPTION**  
 Class F insulation  
 Voltage tolerance  
 AC +15% -10%  
 DC ± 10%  
 Protection class  
 IP65 with connector fitted  
 IP00 without connector  
 Continuous service ED100%

**OPTIONS**  
 Class H insulation  
 Cable attached  
 Special coil voltage  
 Special coil powers

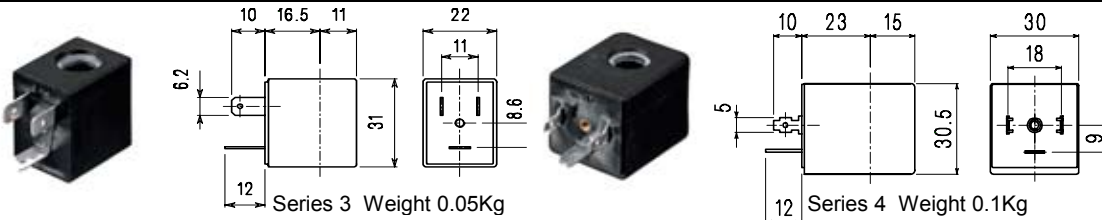

### SPARE PARTS LIST

1. Coil fixing nut
2. Coil
3. Plunger
4. Armature tube with core
5. Diaphragm assembly

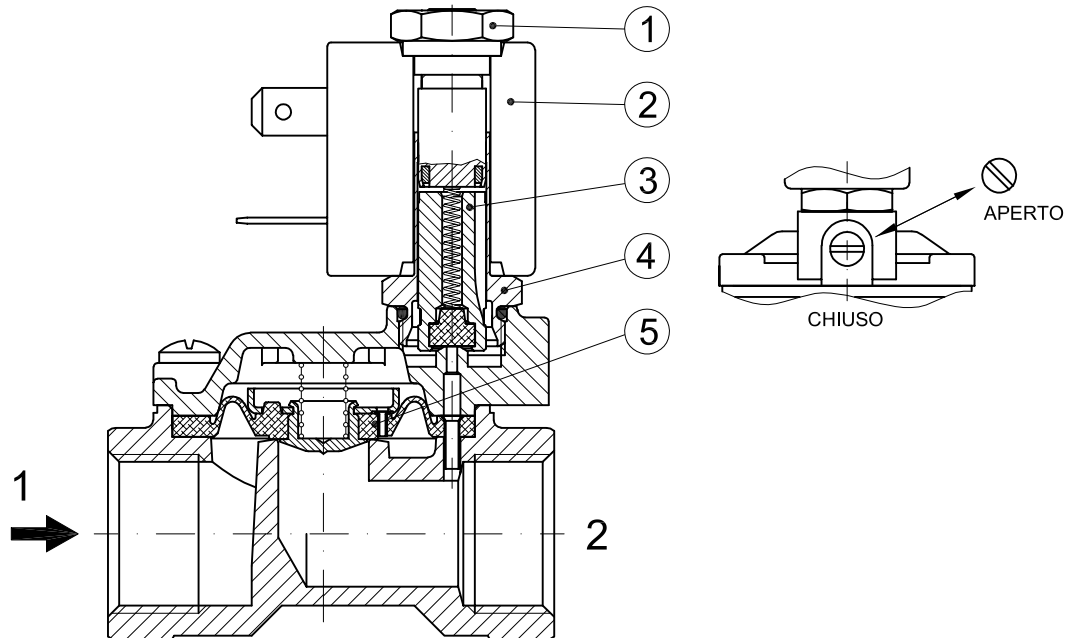

### OVERALL DIMENSION

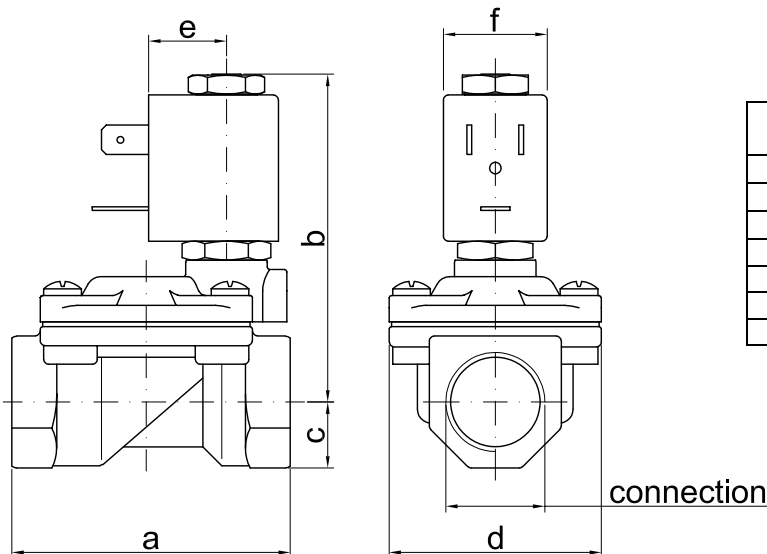

CONNECTION	a	b	c	d	e	f	Weight Kg
G1/4" Ø10	49	65	11	32	16	22	0.25
G3/8" Ø10	49	65	11	32	16	22	0.25
G3/8" Ø12	59	70	14	45	16	22	0.45
G1/2"	59	70	14	45	16	22	0.45
G3/4"	79	74	18	55	16	22	0.65
G1"	96	85	20	72	16	22	1.05
G1"1/4 Ø30	119	92	25	85	16	22	1.80

**DESCRIPTION**

Solenoid valve 2 way normally closed with servo-assisted diaphragm

**CONSTRUCTION**

Body and cover	Brass
Armature tube	Stainless steel
Plunger and core	Stainless steel
Springs	Stainless steel
Seal material	NBR FPM EPDM



**FEATURES**

- Minimum differential pressure 0.15÷3 bar
- Maximum allowable pressure\* : 20 bar
- Maximum fluid viscosity 25cSt (mm<sup>2</sup>/s)
- Ambient temperature : with class F coil -10°C +55°C  
with class H coil -10°C +80°C
- Preferred mounting position with vertical coil above

- OPTIONS** :Manual override  
Electroless nickel plating  
Version for vacuum applications (air/gas)

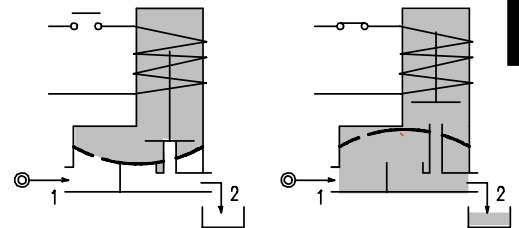
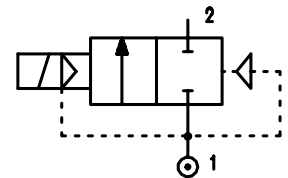

**4**

CODE ① ②	Connection G ISO 228	Orifice mm	KV m <sup>3</sup> /h	Differential pressure bar			Nominal power			Coil		Seal ①	Temp. range °C
				Min	Max		AC Inrush	VA Holding	DC Watt	Series	Width		
					AC	DC							
E107G.....37///.....	1"1/4	37	18	0.15	10	10	20	15	10	2	30	NBR=B	-10 +90
E107H.....37///.....	1"1/2	37	21	0.15	10	10						EPDM=E	<+140
E107I.....50///.....	2"	50	36	0.15	10	10						FPM=V	-10 +130
E107MB75///.....	2"1/2	75	75	0.3	5	5	20	15	10	2	30	NBR=B	-10 +90
E107RB75///.....	3"	75	84	0.3	5	5							
③E107MB75/W/.....	2"1/2	75	75	3	15	15							
③E107RB75/W/.....	3"	75	84	3	15	15							

- ① Seal
  - ② Coil
  - ③ Reinforced diaphragm
- Example: E107IB50///201 NBR seal  
Coil 24V DC

\* REMARK: The maximum allowable pressure PS for steam is 2,5bar (gauge pressure)

COIL	Alternating Current ~50/60Hz Volt							Direct Current Volt			Electrical connection	Connectors
	12	24	48	110	220 230	240	380	12	24	48		
Series 2 Width 30 Code ②	20A	20B	20C	20D	20E	20F	20G	200	201	202	DIN 43650A	PG9 code 10349000

**DESCRIPTION**  
 Insulation class  
 Series 2=F  
 Voltage tolerance  
 AC +15% -10%  
 DC ± 10%  
 Protection class  
 IP65 with connector fitted  
 IP00 without connector  
 Continuous service ED100%

**OPTIONS**  
 Class H insulation  
 Cable attached  
 Special coil voltages  
 Special coil powers

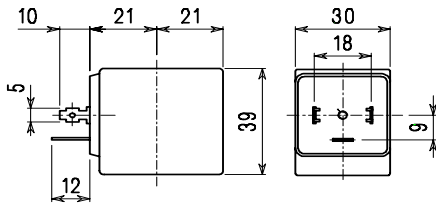

Series 2 Weight 0.12Kg

### SPARE PARTS LIST

1. Coil fixing nut
2. Coil
3. Plunger
4. Armature tube with core
5. Diaphragm assembly
6. Speed control valve
7. Water hammering reducer  
 $\varnothing 0.8-\varnothing 1-\varnothing 1.2$

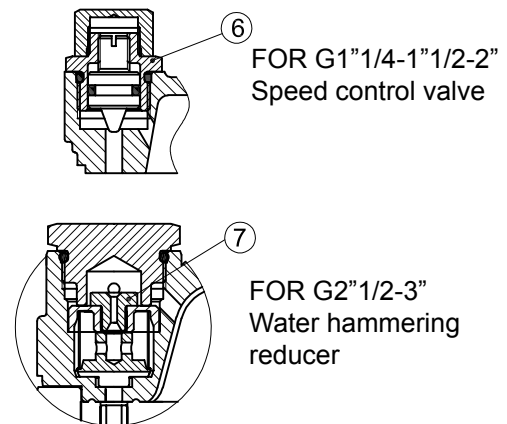
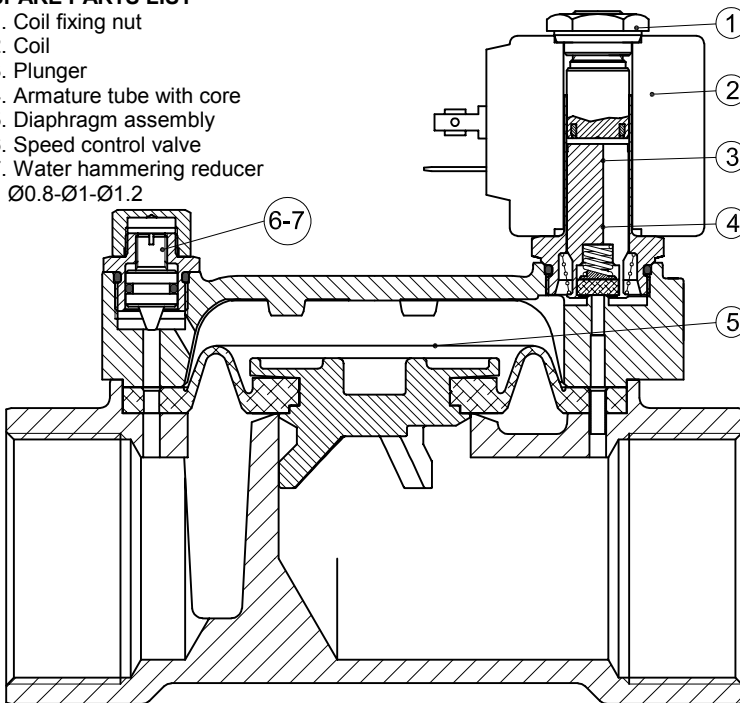

### OVERALL DIMENSION

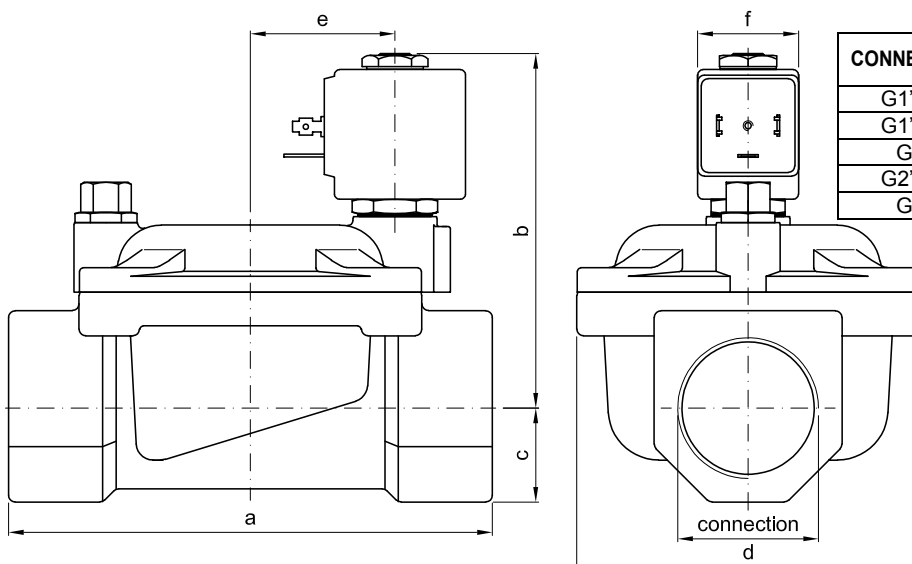

CONNECTION	a	b	c	d	e	f	Weight Kg
G1 1/4	142	107	28	102	21	30	2.95
G1 1/2	142	107	28	102	21	30	2.74
G2"	158	117	35	119	21	30	4.32
G2 1/2	226	134	51	169	21	30	10
G3"	226	134	51	169	21	30	9.65

**DESCRIPTION**

Solenoid valve 2 way normally closed with servo-assisted diaphragm and explosion proof coil certified: CESI 03 ATEX 344 ExII2G/D EEx “d” IIC T6

**VALVE CONSTRUCTION**

Body and cover Brass  
 Seal material FPM  
 NBR

**EXPLOSION PROOF CONSTRUCTION**

Housing Red colour alloy  
 Electrical connection ½” NPT

**FEATURES**

Minimum differential pressure 0.15 bar  
 Maximum allowable pressure 25 bar  
 Maximum fluid viscosity 25cSt (mm<sup>2</sup>/s)  
 Ambient temperature : -10°C +40°C  
 Preferred mounting position with vertical coil above

**OPTIONS :** Electroless nickel plating  
 Version with slow closing diaphragm

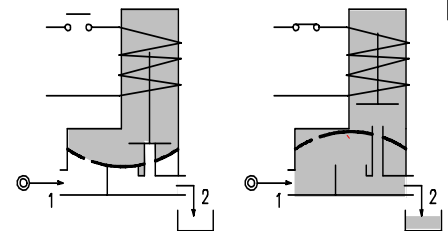
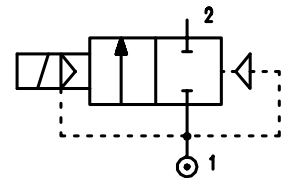

**4**

**NOTE:** The solenoid valve is suitable only with media that are **NOT** potentially explosive.

CODE ①	Connection G ISO 228	Orifice mm	KV m <sup>3</sup> /h	Differential pressure bar			Nominal power		Coil ① Series	Seal	Temp. range °C
				Min	Max		AC Holding	DC			
					AC	DC					
A107BV10/1/.....	1/4"	10	1.5	0.15	15	15	12VA	8W	A6	FPM=V	-10 +130
A107CV10/1/.....	3/8"	10	1.7	0.15	15	15					
A107CV12/1/.....	3/8"	12	2.2	0.15	15	15					
A107DV12/1/.....	1/2"	12	2.5	0.15	15	15					
A107EV18/1/.....	3/4"	18	5.5	0.15	13	13					
A107FV25/1/.....	1"	24	10.2	0.15	10	10					
A107GV30/1/.....	1"1/4	30	15	0.15	10	10					
A107GV37/1/.....	1"1/4	37	18	0.15	10	10					
A107HV37/1/.....	1"1/2	37	21	0.15	10	10					
A107IV50/1/.....	2"	50	36	0.15	10	10					
A107MB75/1/.....	2"1/2	75	75	0.3	5	10				NBR=B	-10 +90
A107RB75/1/.....	3"	75	84	0.3	5	10					

① Coil

Example: A107DV12/1/A6E FPM seal  
 Coil 230V 50-60Hz

Note: For G2"1/2 e G3" NBR seal only

COILS	Alternating Current ~50/60Hz Volt				Direct current Volt			Electrical connection
	24	48	110	220 230	12	24	48	
Series <b>A6</b> Code ①	A6B	A6C	A6D	A6E	A60	A61	A62	1/2" NPT

**DESCRIPTION**  
Voltage tolerance  
AC +15% -10%  
DC ± 10%  
Protection class IP66

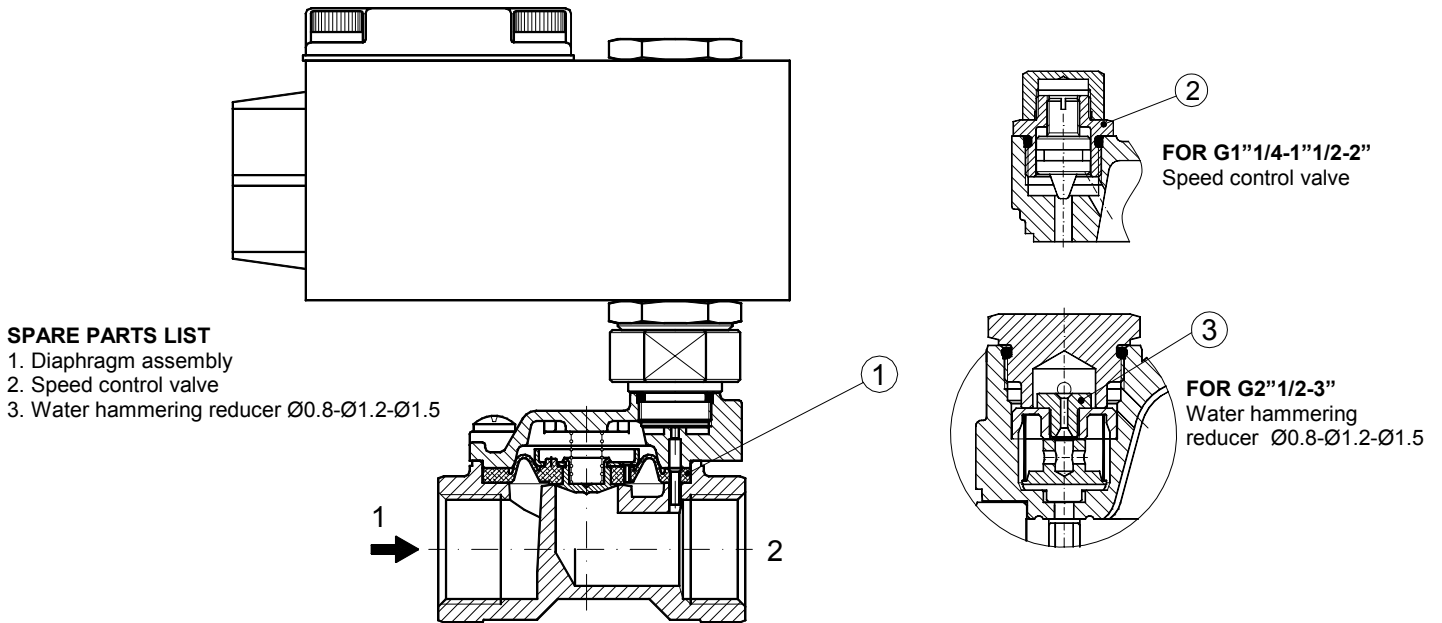

### OVERALL DIMENSION

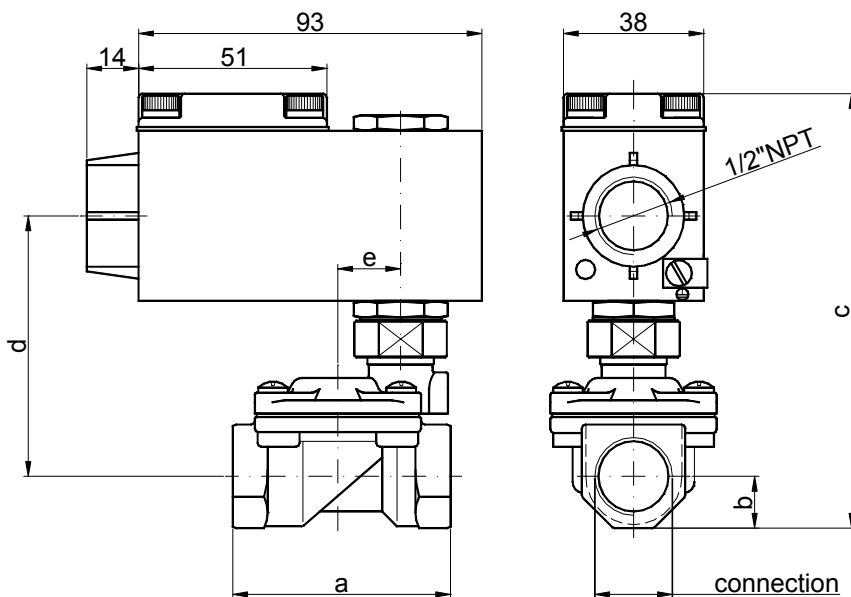

CONNECTION	a	b	c	d	e	Weight Kg
G1/4" Ø10	49	11	110	66	16	0.72
G3/8" Ø10	49	11	110	66	16	0.72
G3/8" Ø12	59	14	118	70	17	0.92
G1/2"	59	14	118	70	17	0.92
G3/4"	79	18	127	75.5	22.2	1.12
G1"	96	20	141	88	30.2	1.50
G1"1/4 Ø30	119	25	150	91	36	2.27
G1"1/4	142	28	147	86	43	3.33
G1"1/2	142	28	147	86	43	3.12
G2"	158	35	168	95	48	4.72
G2"1/2	226	51	197	112	69.2	10.40
G3"	226	51	197	112	69.2	10

**DESCRIPTION**

Solenoid valve 2 way normally closed with assisted lift diaphragm

**CONSTRUCTION**

Body and cover	Brass
Armature tube	Stainless steel
Plunger and core	Stainless steel
Springs	Stainless steel
Seal material	FPM



**FEATURES**

Maximum allowable pressure 25 bar  
 Maximum fluid viscosity 25cSt (mm<sup>2</sup>/s)  
 Ambient temperature : with class F coil -10°C +55°C  
 with class H coil -10°C +80°C  
 Preferred mounting position with vertical coil above  
 For complete diaphragm opening, a differential pressure of at least 0,15 bar is necessary

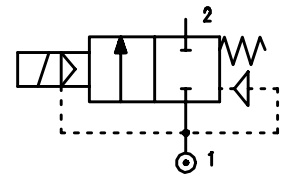

**4**

**OPTIONS :** Electroless nickel plating

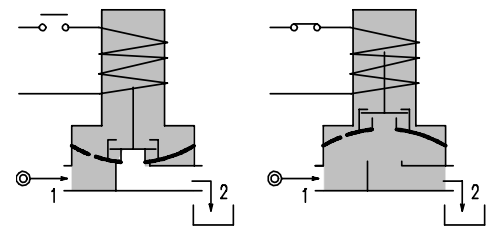

CODE ① ②	Connection G ISO 228	Orifice mm	KV m <sup>3</sup> /h	Differential pressure bar			Nominal power			Coil		Seal ①	Temp. range °C
				Min	Max		AC Inrush	VA Holding	DC Watt	Series	Width		
					AC	DC							
E108C.....12///.....	3/8"	12	2	0	10	-	20	15	-	2	30	FPM=V	-10 +130
E108D.....12///.....	1/2"	12	2.2	0	10	-	20	15	-				
E108C.....12///.....	3/8"	12	2	0	12	10	40	30	27	5	36		
E108D.....12///.....	1/2"	12	2.2	0	12	10	40	30	27				
E108E.....18///.....	3/4"	18	4.5	0	9	-	40	30	-				
E108F.....25///.....	1"	24	8.5	0	7	-	40	30	-				
D108E.....18///.....	3/4"	18	4.5	0	-	9	-	-	27				
D108F.....25///.....	1"	24	8.5	0	-	8	-	-	27				

- ① Seal
- ② Coil

Example: E108FV25///52E FPM seal  
 Coil 230V 50-60Hz

COILS	Alternating Current ~50/60Hz Volt							Direct Current Volt			Electrical connection	Connectors
	12	24	48	110	220 230	240	380	12	24	48		
Series 2 Width 30 Code ②	20A	20B	20C	20D	20E	20F	20G	200	201	202	DIN 43650A	PG9 code 10349000
Series 5 Width 36 Code ②	52A	52B	52C	52D	52E	52F	52G	520	521	522	DIN 43650A	PG11 code 10349001

**DESCRIPTION**  
 Insulation class  
 Series 2=F Series 5=H  
 Voltage tolerance  
 AC +15% -10%  
 DC ± 10%  
 Protection class  
 IP65 with connector fitted  
 IP00 without connector  
 Continuous service ED100%

**OPTIONS**  
 Insulation class H (series 2)  
 Cable attached  
 Special coil voltages  
 Special coil powers

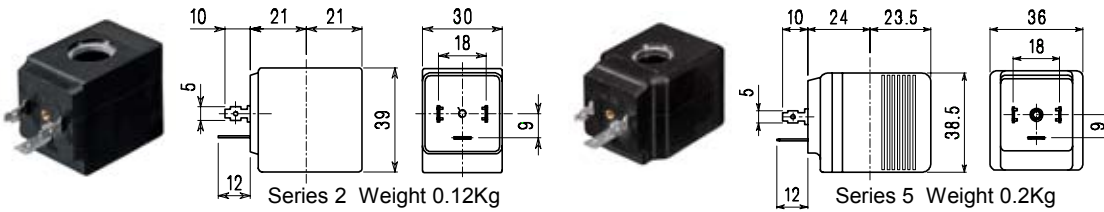

Series 2 Weight 0.12Kg

Series 5 Weight 0.2Kg

### SPARE PARTS LIST

1. Coil fixing nut
2. Coil
3. Plunger and diaphragm assembly
4. Armature tube with core

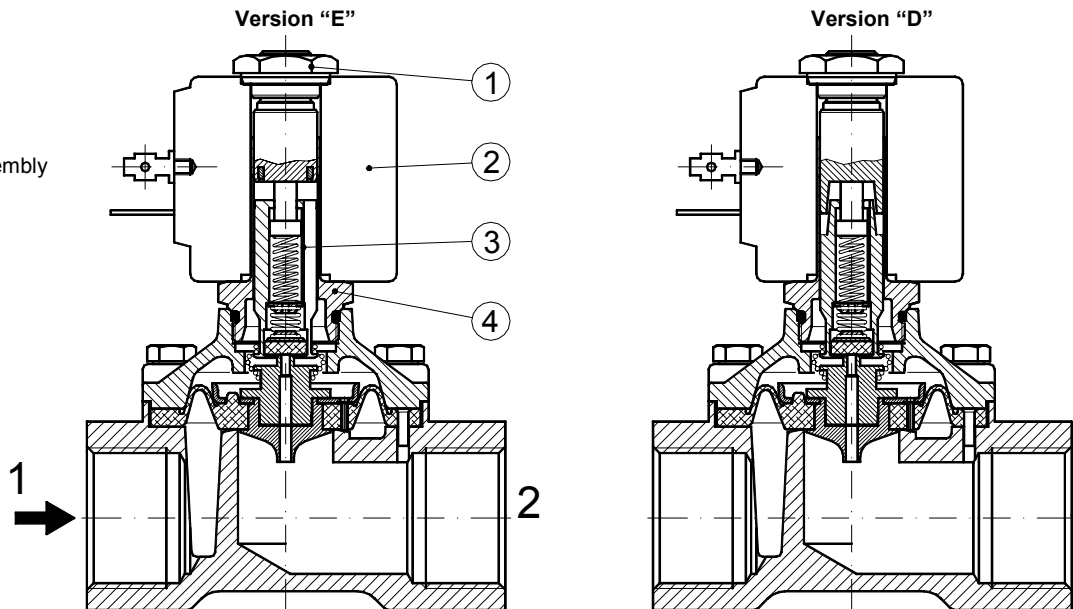

### OVERALL DIMENSION

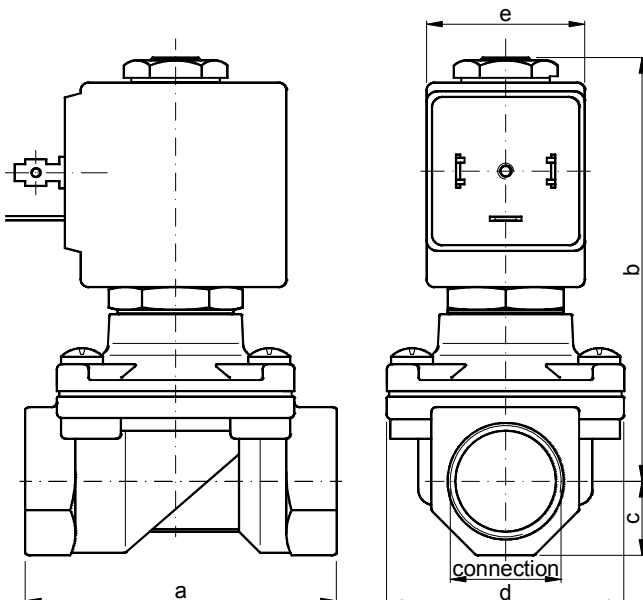

CONNECTION	a	b	c	d	e with		Weight Kg	
					series 2	series 5	series 2	series 5
G3/8" Ø12	59	83	14	45	30	36	0.50	0.58
G1/2"	59	83	14	45	30	36	0.45	0.53
G3/4"	79	90	18	55	-	36	-	0.75
G1"	96	101	20	72	-	36	-	1.10



**DESCRIPTION**

Solenoid valve 2 way with servo-assisted diaphragm bi-stable.

The bi-stable function is achieved by the use of a polarised permanent magnet energising the coil with a DC current for at least 15ms in the reverse direction of the preceding impulse.



**CONSTRUCTION**

Body and cover	Brass
Armature tube	Stainless steel
Plunger and core	Stainless steel
Magnet	NeFeB
Springs	Stainless steel
Seal material	NBR FPM EPDM

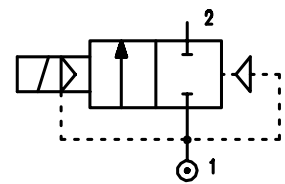

**FEATURES**

- Minimum differential pressure 0.15 bar
- Maximum allowable pressure 25 bar
- Maximum fluid viscosity 25cSt (mm<sup>2</sup>/s)
- Ambient temperature : with class F coil -10°C +55°C  
with class H coil -10°C +80°C
- Preferred mounting position with vertical coil above

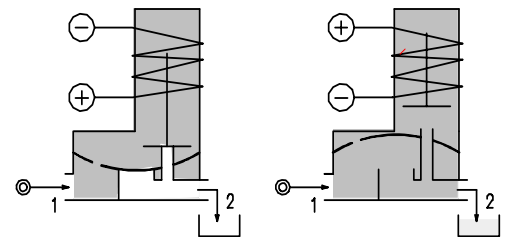

4

**OPTIONS :** Special coil powers  
Certified versions:



CODE ① ②	Connection G ISO 228	Orifice mm	KV m <sup>3</sup> /h	Differential pressure bar			Nominal power			Coil		Seal ①	Temp. range °C
				Min	Max		AC Inrush	VA Holding	DC Watt	Series	Width		
					AC	DC							
D117B.....10///.....	1/4"	10	1.5	0.15	-	8	-	-	2	3	22	NBR=B	-10 +90
		10	1.5	0.15	-	15	-	-	5				
D117C.....10///.....	3/8"	10	1.7	0.15	-	8	-	-	2				
		10	1.7	0.15	-	15	-	-	5				
D117C.....12///.....	3/8"	12	2.2	0.15	-	8	-	-	2				
		12	2.2	0.15	-	15	-	-	5				
D117D.....12///.....	1/2"	12	2.5	0.15	-	8	-	-	2				
		12	2.5	0.15	-	15	-	-	5				
D117E.....18///.....	3/4"	18	5.5	0.15	-	8	-	-	2				
		18	5.5	0.15	-	13	-	-	5				
D117F.....25///.....	1"	25	10.2	0.15	-	8	-	-	2				
		25	10.2	0.15	-	10	-	-	5				
D117G.....30///.....	1" 1/4	30	15	0.15	-	8	-	-	2				
		30	15	0.15	-	10	-	-	5				

- ① Seal
- ② Coil

Example: D117DB12///301120 NBR seal  
Coil 24V DC 2W

COIL	DIRECT CURRENT															Electrical connection	Connectors
	3V			6V			9V			12V			24V				
	2W	5W	6.5W	2W	5W	6.5W	2W	5W	6.5W	2W	5W	6.5W	2W	5W	6.5W		
Series 3 Width 22 Code ②	308120			305120	305150		307120	307150		300120	300150	300	301120	301150	301	DIN 46244	PG9 code 10348000

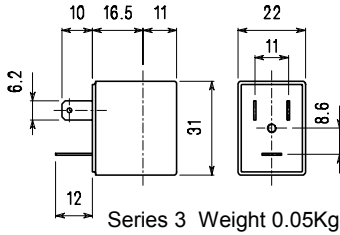

**DESCRIPTION**  
 Class F insulation  
 Voltage tolerance  $\pm 10\%$   
 Protection class  
 IP65 with connector fitted  
 IP00 without connector

**OPTIONS**  
 Class H insulation  
 Cable attached  
 Special coil voltages  
 Special coil powers

**SPARE PARTS LIST**

1. Coil fixing nut
2. Coil
3. Plunger
4. Armature with core
5. Diaphragm assembly

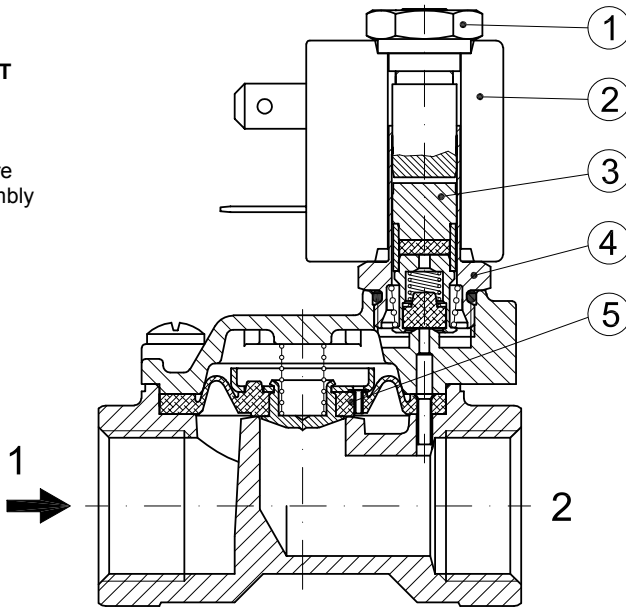

**OVERALL DIMENSION**

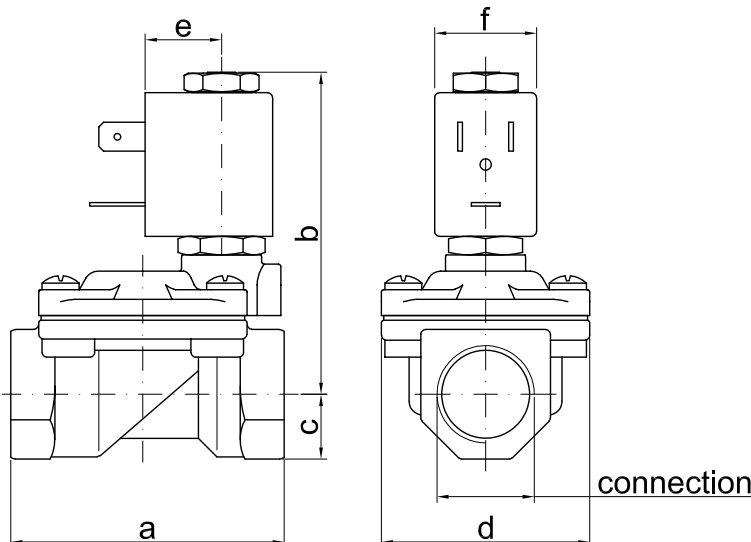

CONNECTION	a	b	c	d	e	f	Weight Kg
G1/4" Ø10	49	65	11	32	16	22	0.25
G3/8" Ø10	49	65	11	32	16	22	0.25
G3/8" Ø12	59	70	14	45	16	22	0.45
G1/2"	59	70	14	45	16	22	0.40
G3/4"	79	74	18	55	16	22	0.66
G1"	96	85	20	72	16	22	1.05
G1"1/4 Ø30	119	92	25	85	16	22	1.80

**DESCRIPTION**

Solenoid valve 2 way with servo-assisted diaphragm bi-stable.

The bi-stable function is achieved by the use of a polarized permanent magnet energising the coil with a DC current for at least 15ms in the reverse direction of the preceding impulse.



**CONSTRUCTION**

Body and cover	Brass
Armature tube	Stainless steel
Plunger and core	Stainless steel
Magnet	NeFeB
Springs	Stainless steel
Seal material	NBR FPM EPDM

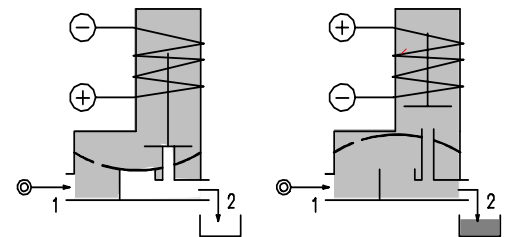
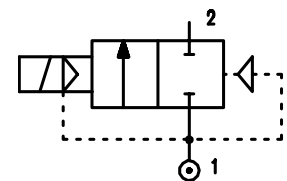

4

**FEATURES**

- Minimum differential pressure 0.15÷3 bar
- Maximum allowable pressure 20 bar
- Maximum fluid viscosity 25cSt (mm<sup>2</sup>/s)
- Ambient temperature : with class F coil -10°C +55°C  
with class H coil -10°C +80°C
- Preferred mounting position with vertical coil above

**OPTIONS** : Special coil powers

CODE ① ②	Connection G ISO 228	Orifice mm	KV m <sup>3</sup> /h	Differential pressure bar			Nominal power			Coil		Seal ①	Temp. range °C
				Min	Max		AC Inrush	VA Holding	DC Watt	Series	Width		
					AC	DC							
D117G.....37///.....	1"1/4	37	18	0.15	-	10	-	-	10	2	30	NBR=B	-10 +90
D117H.....37///.....	1"1/2	37	21	0.15	-	10						EPDM=E	<+120
D117I.....50///.....	2"	50	36	0.15	-	10						FPM=V	-10 +120
D117MB75///.....	2"1/2	75	75	0.3	-	5	-	-	10	2	30	NBR=B	-10 +90
D117RB75///.....	3"	75	84	0.3	-	5							
③D117MB75/W/.....	2"1/2	75	75	3	-	10							
③D117RB75/W/.....	3"	75	84	3	-	10							

- ① Seal
  - ② Coil
  - ③ Reinforced diaphragm
- Example: D117IB50///201 NBR seal  
Coil 24V DC

\* REMARK: The maximum allowable pressure PS for steam is 2,5bar (gauge pressure)

COIL	Direct Current Volt			Electrical connection	Connectors
	12	24	48		
Series 2 Width 30 Code ②	200	201	202	DIN 43650A	PG9 code 10349000

**DESCRIPTION**  
 Insulation class F  
 Voltage tolerance  $\pm 10\%$   
 Protection class  
 IP65 with connector fitted  
 IP00 without connector

**OPTIONS**  
 Class H insulation  
 Cable attached  
 Special coil voltages  
 Special coil powers

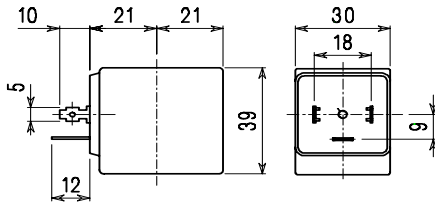

Series 2 Weight 0.12Kg

**SPARE PARTS LIST**

1. Coil fixing nut
2. Coil
3. Plunger
4. Armature tube with core
5. Diaphragm assembly
6. Speed control valve
7. Water hammering reducer  
 $\varnothing 0.8-\varnothing 1-\varnothing 1.2$

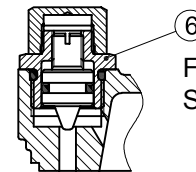
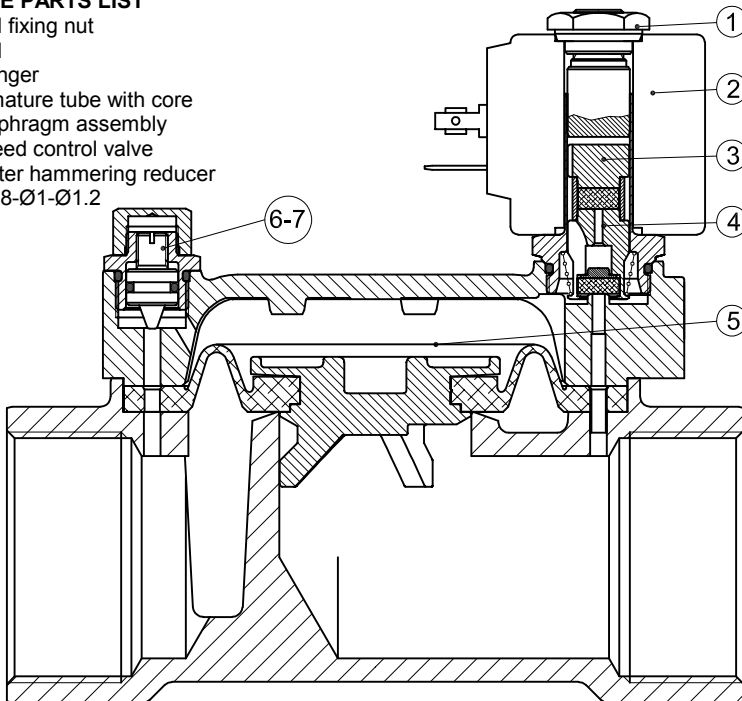

FOR G1"1/4-1"1/2-2"  
 Speed control valve

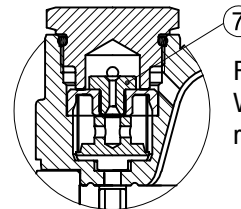

FOR G2"1/2-3"  
 Water hammering reducer

**OVERALL DIMENSION**

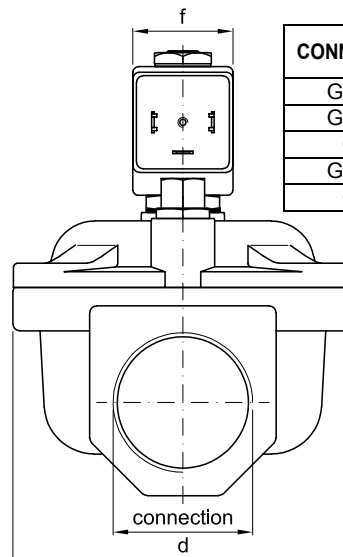
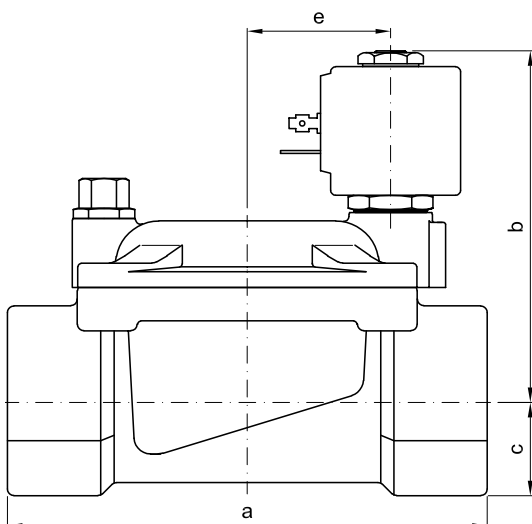

CONNECTION	a	b	c	d	e	f	Weight Kg
G1"1/4	142	107	28	102	21	30	2.95
G1"1/2	142	107	28	102	21	30	2.74
G2"	158	117	35	119	21	30	4.32
G2"1/2	226	134	51	169	21	30	10
G3"	226	134	51	169	21	30	9.65

**DESCRIPTION**

Solenoid valve 2 way normally closed with servo-assisted piston

**CONSTRUCTION**

Body and cover	Brass
Armature tube	Stainless steel
Plunger and core	Stainless steel
Springs	Stainless steel
Piston	Brass
Piston ring	PTFE reinforced
Seal material	Main seal PTFE other FPM



**FEATURES**

- Minimum differential pressure 1 bar
- Maximum allowable pressure 40 bar (60 bar version /1)
- Maximum fluid viscosity 25cSt (mm<sup>2</sup>/s)
- Ambient temperature : with class F coil -10°C +55°C  
with class H coil -10°C +80°C
- Preferred mounting position with vertical coil above

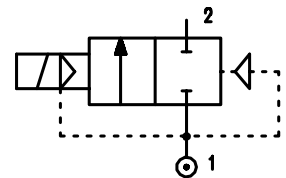

**4**

**OPTIONS :** Electroless nickel plating

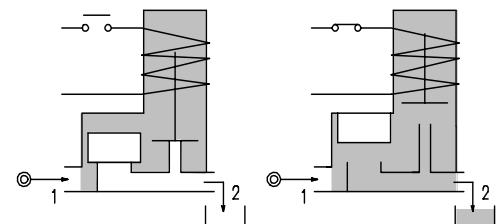

CODE ①	Connection G ISO 228	Orifice mm	KV m <sup>3</sup> /h	Differential pressure bar			Nominal power			Coil		Seal	Temp. range °C
				Min	Max		AC Inrush	VA Holding	DC Watt	Series	Width		
					AC	DC							
E119BV52///.....	1/4"	5.2	0.47	1.5	50	50	20	15	10	2	30	PTFE/FPM	-10 +130
E119CV12///.....	3/8"	12	2	1	30	30							
E119DV12///.....	1/2"	12	2.2	1	30	30							
②E119CV12/1/.....	3/8"	12	2	1	50	50	40	30	27	5	36		
②E119DV12/1/.....	1/2"	12	2.2	1	50	50							

- ① Coil
  - ② Maximum allowable pressure 60 bar
- Maximum allowable leakage < 0.2 nL/h

Example: E119DV12/1/521 FPM seal  
Coil 24V DC  
Maximum differential pressure 50 bar

COILS	Alternating Current ~50/60Hz Volt							Direct current Volt			Electrical connection	Connectors
	12	24	48	110	220 230	240	380	12	24	48		
Series 2 Width 30 Code ①	20A	20B	20C	20D	20E	20F	20G	200	201	202	DIN 43650A	PG9 code 10349000
Series 5 Width 36 Code ①	52A	52B	52C	52D	52E	52F	52G	520	521	522	DIN 43650A	PG11 code 10349001

**DESCRIPTION**  
 Insulation class  
 Series 2=F Series 5=H  
 Voltage tolerance  
 AC +15% -10%  
 DC ± 10%  
 Protection class  
 IP65 with connector fitted  
 IP00 without connector  
 Continuous service ED100%

**OPTIONS**  
 Class H insulation (series 2)  
 Cable attached  
 Special coil voltages  
 Special coil powers

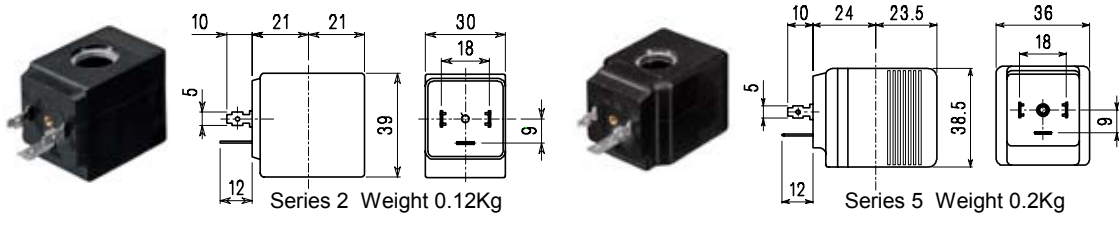

**SPARE PARTS LIST**

1. Coil fixing nut
2. Coil
3. Plunger
4. Armature tube with core
5. Piston assembly

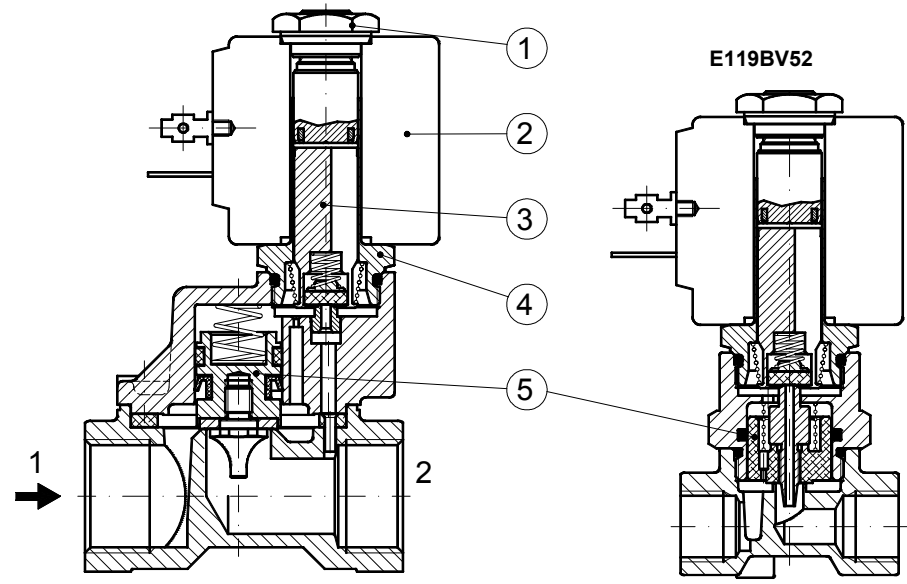

**OVERALL DIMENSION**

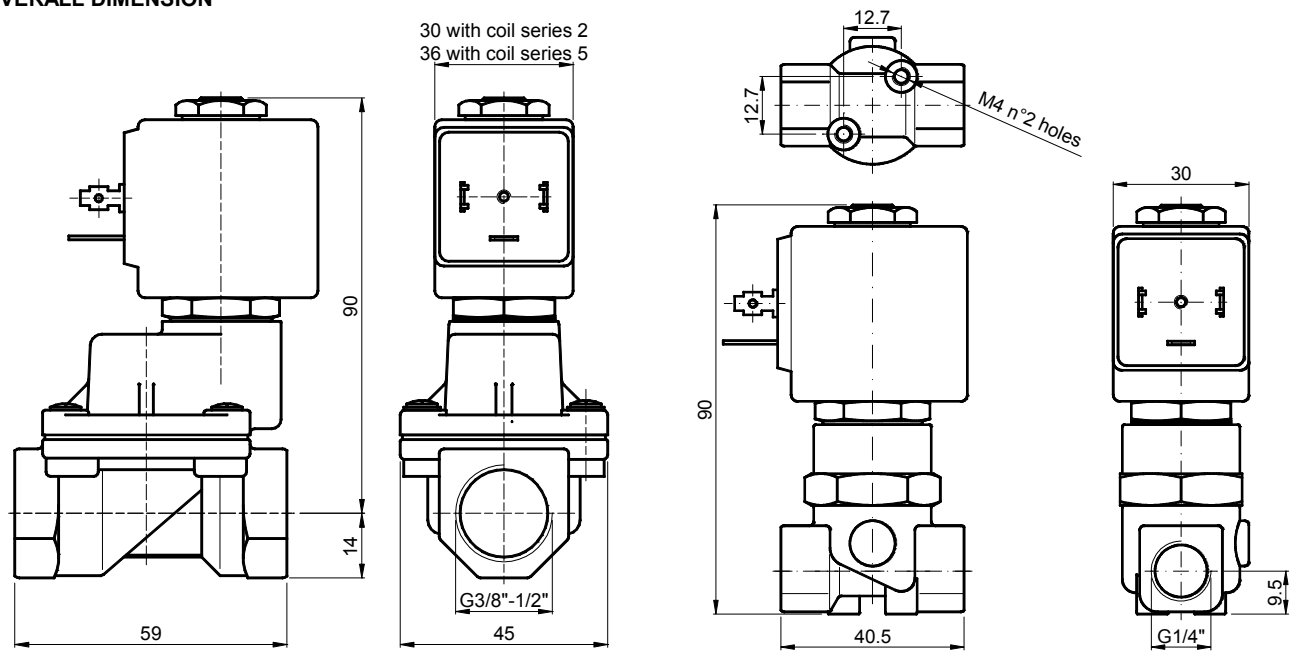

Weight with coil series 2 = 0.63 Kg  
 Weight with coil series 5 = 0.71 Kg

**DESCRIPTION**

Solenoid valve 2 way normally closed with servoassisted piston for use with steam

**CONSTRUCTION**

Body and cover	Brass
Armature tube	Stainless steel
Plunger and core	Stainless steel
Springs	Stainless steel
Piston	Stainless steel
Piston ring	PTFE reinforced
Seal material	Main seal PTFE others FPM



**FEATURES**

Minimum differential pressure 2.5 bar  
 Ambient temperature with class H coil only : -10°C +80°C  
 Preferred mounting position with vertical coil above

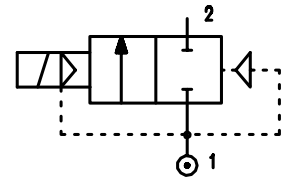

**OPTIONS :** Electroless nickel plating

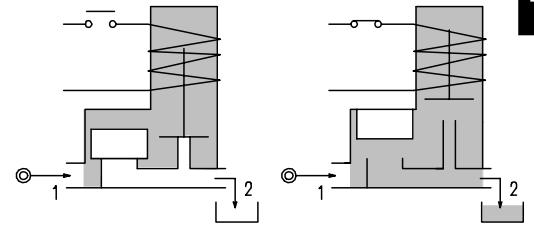

**4**

CODE ①	Connection G ISO 228	Orifice mm	KV m³/h	Differential pressure bar			Nominal power			Coil		Seal	Temp. range °C
				Min	Max		AC Inrush	VA Holding	DC Watt	Series	Width		
					AC	DC							
E119CW12/1/.....	3/8"	12	2	2.5	9	9	20	15	10	2	30	PTFE	-10 +180
E119DW12/1/.....	1/2"	12	2.2	2.5	9	9	20	15	10	2	30		

① Coil

Example: E119DW12/1/221 PTFE seal  
 Coil 24V DC

Maximum allowable leakage < 0.2 nL/h

COIL	Alternating Current ~50/60Hz Volt							Direct Current Volt			Electrical connection	Connectors
	12	24	48	110	220 230	240	380	12	24	48		
Series 2 Width 30 Code ①	22A	22B	22C	22D	22E	22F	22G	220	221	222	DIN 43650A	PG9 code 10349000

**DESCRIPTION**  
 Class H insulation  
 Voltage tolerance  
 AC +15% -10%  
 DC ± 10%  
 Protection class  
 IP65 with connector fitted  
 IP00 without connector  
 Continuous service ED100%

**OPTIONS**  
 Cable attached  
 Special coil powers  
 Special coil voltages

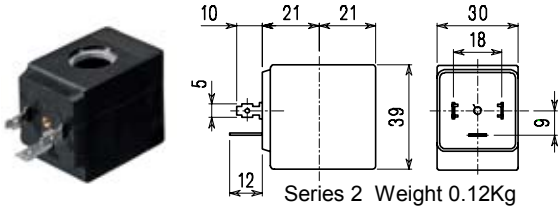

### SPARE PARTS LIST

1. Coil fixing nut
2. Coil
3. Plunger
4. Armature tube with core
5. Piston assembly

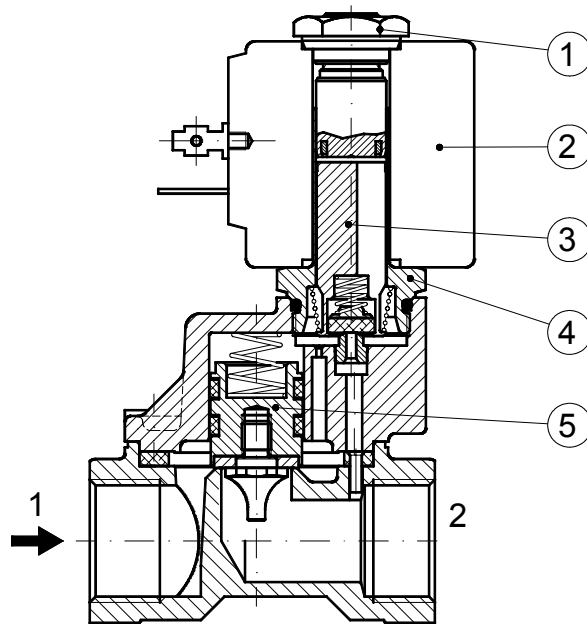

### OVERALL DIMENSION

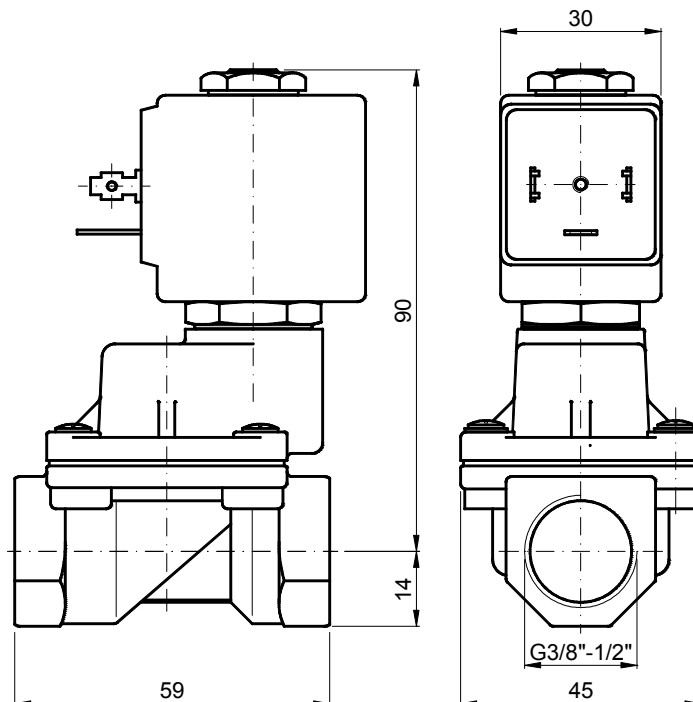

Weight = 0.63 Kg





COIL	Alternating Current ~50/60Hz Volt							Direct Current Volt			Electrical connection	Connectors
	12	24	48	110	220 230	240	380	12	24	48		
Series 3 Width 22 Code ②	30A	30B	30C	30D	30E	30F	30G	300	301	302	DIN 46244	PG9 code 10348000

**DESCRIPTION**  
 Class F insulation  
 Voltage tolerance  
 AC +15% -10%  
 DC ± 10%  
 Protection class  
 IP65 with connector fitted  
 IP00 without connector  
 Continuous service ED100%

**OPTIONS**  
 Class H insulation  
 Cable attached  
 Special coil powers  
 Special coil voltages

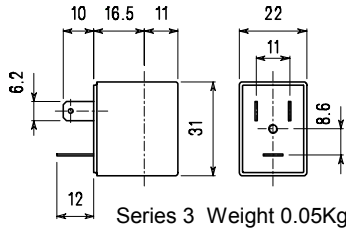

### SPARE PARTS LIST

1. Coil fixing nut
2. Coil
3. Plunger
4. Armature tube with core
5. Diaphragm assembly

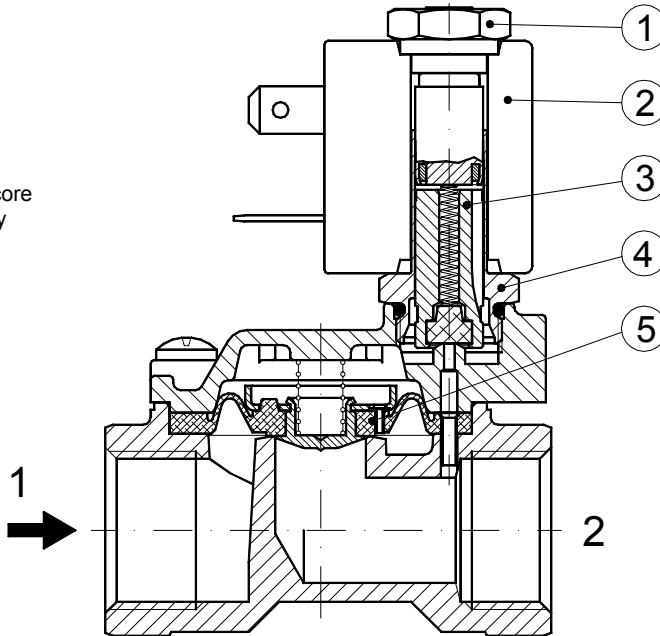

### MANUAL OVERRIDE

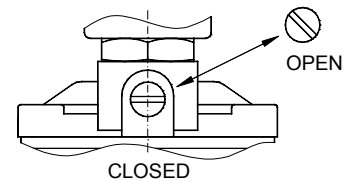

### OVERALL DIMENSION

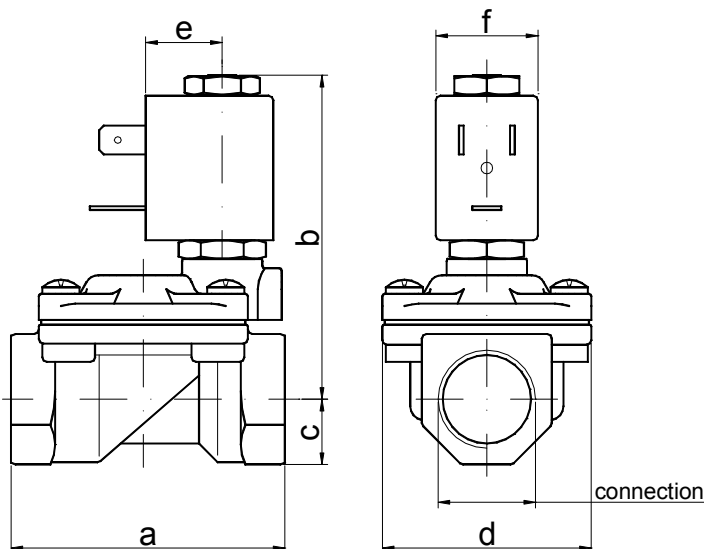

CONNECTION	a	b	c	d	Weight Kg
G3/8" Ø12	59	70	11	45	0.31
G1/2"	59	70	13	45	0.32
G3/4"	79	74	18	54	0.75
G1"	96	85	20	72	1.35

**DESCRIPTION**

Solenoid valve 2 way normally closed in stainless steel AISI 316 with servo-assisted diaphragm and explosion proof coil certified: CESI 03 ATEX 344 ExII2G/D EEx “d” IIC T6

**VALVE CONSTRUCTION**

Body and cover                      Stainless steel  
 Seal material                        FPM

**EXPLOSION PROOF CONSTRUCTION**

Housing                                Red colour alloy  
 Electrical connection            ½” NPT

**FEATURES**

Minimum differential pressure 0.15 bar  
 Maximum allowable pressure 25 bar  
 Maximum fluid viscosity 25cSt (mm<sup>2</sup>/s)  
 Ambient temperature :    -10°C +40°C  
 Preferred mounting position with vertical coil above

**OPTIONS :** Version with slow closing diaphragm

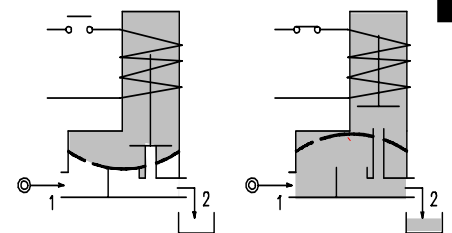
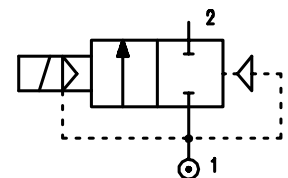

**4**

**NOTE:** The solenoid valve is suitable only with media that are **NOT** potentially explosive.

CODE ①	Connection G ISO 228	Orifice mm	KV m <sup>3</sup> /h	Differential pressure bar			Nominal power		Coil ① Series	Seal	Temp. range °C
				Min	Max		AC Holding	DC			
					AC	DC					
A177CV12/1/.....	3/8"	12	2.2	0.15	15	15	12VA	8W	A6	FPM=V	-10 +130
A177DV12/1/.....	1/2"	12	2.5	0.15	15	15					
A177EV18/1/.....	3/4"	18	5.5	0.15	13	13					
A177FV25/1/.....	1"	24	10.2	0.15	10	10					

① Coil

Example: A177DV12/1/A6E FPM seal  
 Coil 230V 50-60Hz

COILS	Alternating Current ~50/60Hz Volt				Direct Current Volt			Electrical connection
	24	48	110	220 230	12	24	48	
Series <b>A6</b> Code ①	A6B	A6C	A6D	A6E	A60	A61	A62	1/2" NPT

**DESCRIPTION**  
 Voltage tolerance  
 AC +15% -10%  
 DC ± 10%  
 Protection class IP66

**SPARE PARTS LIST**  
 1. Diaphragm assembly

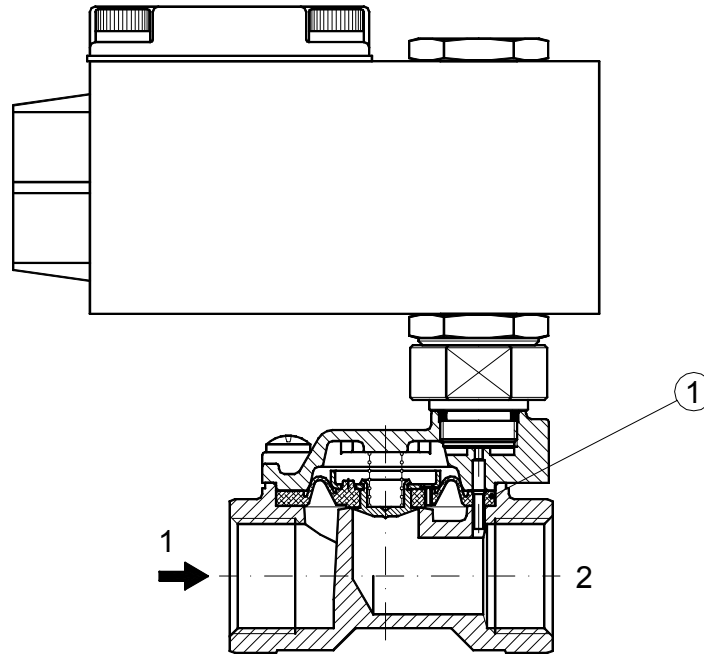

**OVERALL DIMENSION**

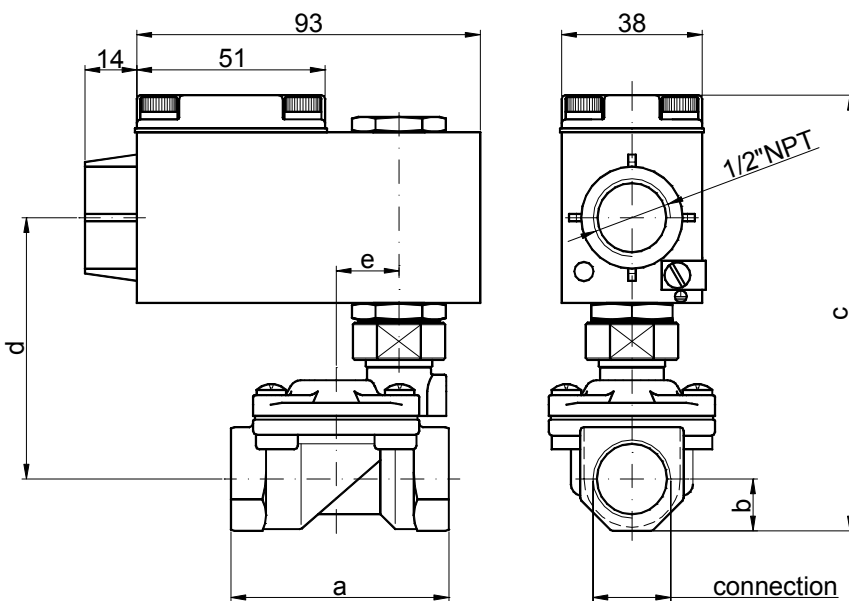

CONNECTION	a	b	c	d	e	Weight Kg
G3/8" Ø12	59	11	118	70	17	1.11
G1/2"	59	13	118	70	17	1.12
G3/4"	79	18	127	75.5	22.2	1.55
G1"	96	20	141	88	30.2	2.15

**DESCRIPTION**

Solenoid valve 2 way normally open with servoassisted diaphragm

**COSNTRUCTION**

Body and cover	Brass
Armature tube	Stainless steel
Plunger and core	Stainless steel
Springs	Stainless steel
Seal	NBR FPM EPDM



**FEATURES**

- Minimum differential pressure 0.15 bar
- Maximum allowable pressure\* : 25 bar
- Maximum fluid viscosity 25cSt (mm<sup>2</sup>/s)
- Ambient temperature: with class F coil -10°C +55°C  
with class H coil -10°C +80°C
- Preferred mounting position with vertical coil above

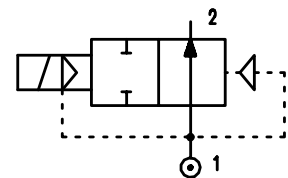

4

**OPTIONS:** Electroless nickel plating  
Explosion proof coil according to ATEX - EExmII Series 7

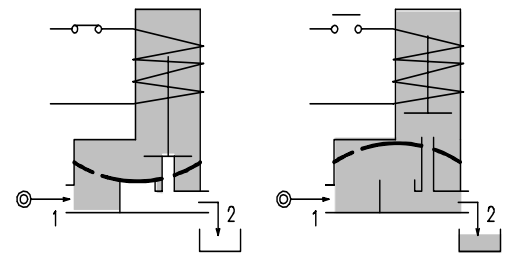

CODE ① ②	Connection G ISO 228	Orifice mm	KV m <sup>3</sup> /h	Differential pressure bar			Nominal power			Coil		Seal ①	Temp. range °C
				Min	Max		AC Inrush	VA Holding	DC Watt	Series	Width		
					AC	DC							
E207B.....10///.....	1/4"	10	1.5	0.15	15	15	12	8	6.5	3	22	NBR=B EPDM=E FPM=V	-10 +90 -<+140 -10 +130
E207C.....10///.....	3/8"	10	1.7	0.15	15	15							
E207C.....12///.....	3/8"	12	2.2	0.15	15	15							
E207D.....12///.....	1/2"	12	2.5	0.15	15	15							
E207E.....18///.....	3/4"	18	5.5	0.15	13	13							
E207F.....25///.....	1"	24	10.2	0.15	10	10							
E207G.....30///.....	1"1/4	30	15	0.15	10	10							

① Seal Example: E207DB12///301 NBR seal  
② Coil Coil 24V DC

\* REMARK: The maximum allowable pressure PS for steam is 2,5bar (gauge pressure)

COILS	Alternating Current ~50/60Hz Volt							Direct Current Volt			Electrical connection	Connectors
	12	24	48	110	220 230	240	380	12	24	48		
Series 3 Width 22 Code ②	30A	30B	30C	30D	30E	30F	30G	300	301	302	DIN 46244	PG9 code 10348000

**DESCRIPTION**  
 Class F insulation  
 Voltage tolerance  
 AC +15% -10%  
 DC ± 10%  
 Protection class  
 IP65 with connector fitted  
 IP00 without connector  
 Continuous service ED100%

**OPTIONS**  
 Class H insulation  
 Cable attached  
 Special coil voltage  
 Special coil powers

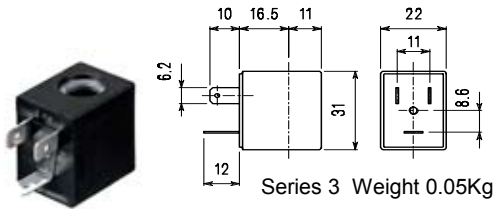

### SPARE PARTS LIST

1. Coil fixing nut
2. Coil
3. Seal assembly
4. Armature tube with core
5. Diaphragm assembly

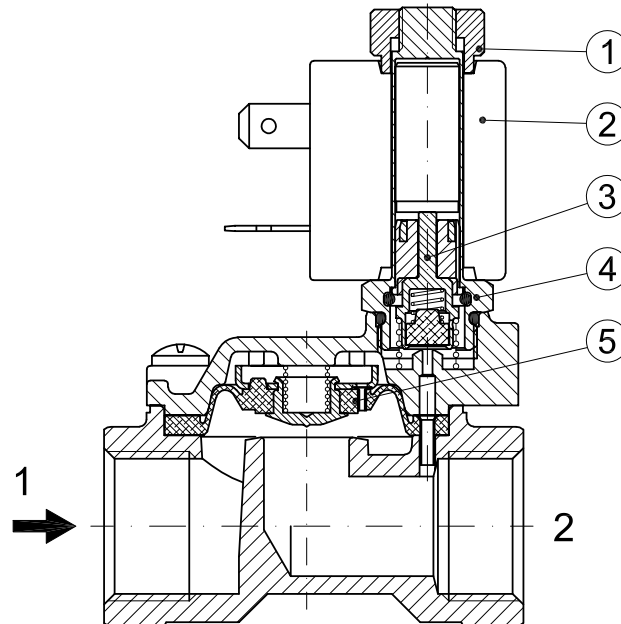

### OVERALL DIMENSION

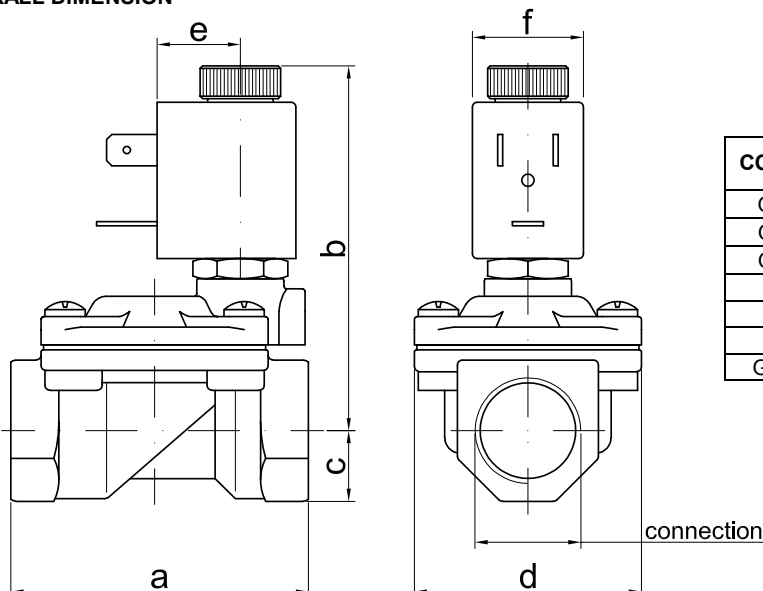

CONNECTION	a	b	c	d	e	f	Weight Kg
G1/4" Ø10	49	64	11	32	16	22	0.25
G3/8" Ø10	49	64	11	32	16	22	0.25
G3/8" Ø12	59	73	14	45	16	22	0.45
G1/2"	59	73	14	45	16	22	0.45
G3/4"	79	75	18	55	16	22	0.66
G1"	96	85	20	72	16	22	1.05
G1 1/4 Ø30	119	96	25	85	16	22	1.80

**DESCRIPTION**

Solenoid valve 2 way normally open with servo-assisted diaphragm

**CONSTRUCTION**

Body and cover	Brass
Armature tube	Stainless steel
Plunger and core	Stainless steel
Springs	Stainless steel
Seal	NBR FPM EPDM



**FEATURES**

- Minimum differential pressure 0.15÷3 bar
- Maximum allowable pressure\* : 20 bar
- Maximum fluid viscosity 25cSt (mm<sup>2</sup>/s)
- Ambient temperature: with class F coil -10°C +55°C  
with class H coil -10°C +80°C
- Preferred mounting position with vertical coil above

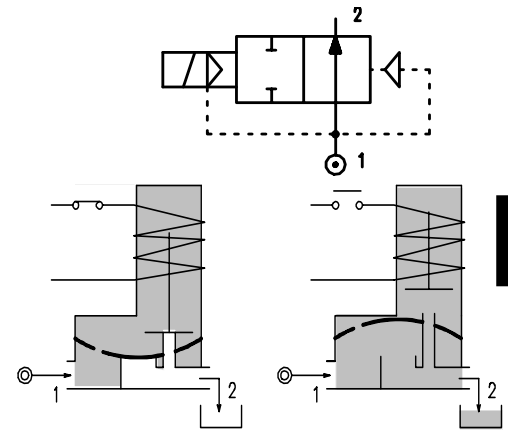

**OPTIONS:** Electroless nickel plating  
Stainless steel armature tube

CODE ① ②	Connection G ISO 228	Orifice mm	KV m <sup>3</sup> /h	Differential pressure bar			Nominal power			Coil		Seal ①	Temp. range °C
				Min	Max		AC Inrush	VA Holding	DC Watt	Series	Width		
					AC	DC							
E207G.....37///.....	1"1/4	37	18	0.15	10	10	20	15	10	2	30	NBR=B	-10 +90
E207H.....37///.....	1"1/2	37	21	0.15	10	10						EPDM=E	<+140
E207I.....50///.....	2"	50	36	0.15	10	10						FPM=V	-10 +130
E207MB75///.....	2"1/2	75	75	0.3	5	5	20	15	10	2	30	NBR=B	-10 +90
E207RB75///.....	3"	75	84	0.3	5	5							
③ E207MB75/W/...	2"1/2	75	75	3	15	15	40	30	27	5	36		
③ E207RB75/W/...	3"	75	84	3	15	15							

- ① Seal
  - ② Coil
  - ③ Reinforced diaphragm
- Example: E207IB50///201 NBR seal  
Coil 24V DC

\* REMARK: The maximum allowable pressure PS for steam is 2,5bar (gauge pressure)

COILS	Alternating Current ~50/60Hz Volt							Direct Current Volt			Electrical connection	Connectors
	12	24	48	110	220 230	240	380	12	24	48		
Series <b>2</b> Width 30 Code ②	20A	20B	20C	20D	20E	20F	20G	200	201	202	DIN 43650A	PG9 code 10349000
Series <b>5</b> Width 36 Code ②	52A	52B	52C	52D	52E	52F	52G	520	521	522	DIN 43650A	PG11 code 10349001

**DESCRIPTION**  
 Insulation class  
 Series 2=F Series 5=H  
 Voltage tolerance  
 AC +15% -10%  
 DC ± 10%  
 Protection class  
 IP65 with connector fitted  
 IP00 without connector  
 Continuous service ED100%

**OPTIONS**  
 Class H insulation (series 2)  
 Cable attached  
 Special coil voltages  
 Special coil powers

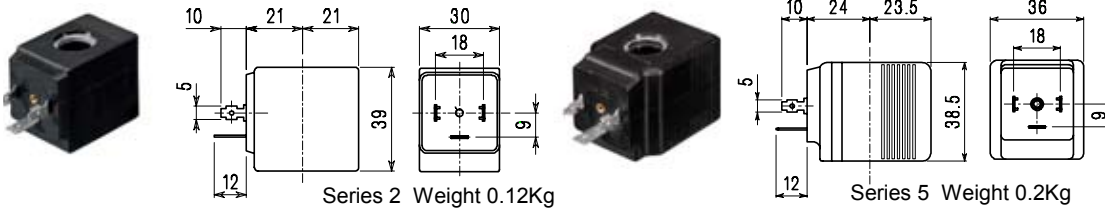

### SPARE PARTS LIST

1. Coil fixing nut
2. Coil
3. Plunger
4. Armature tube with core
5. Diaphragm assembly
6. Speed control valve
7. Water hammering reducer  
Ø0.8-Ø1-Ø1.2

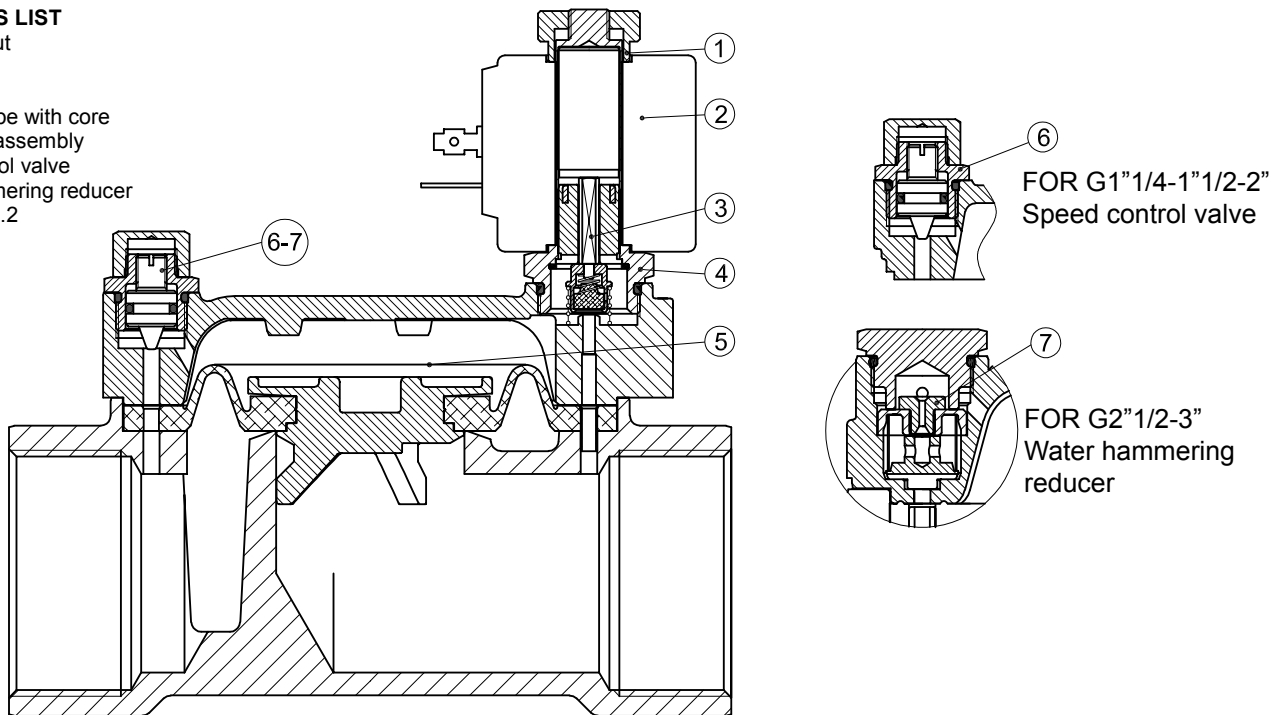

### OVERALL DIMENSION

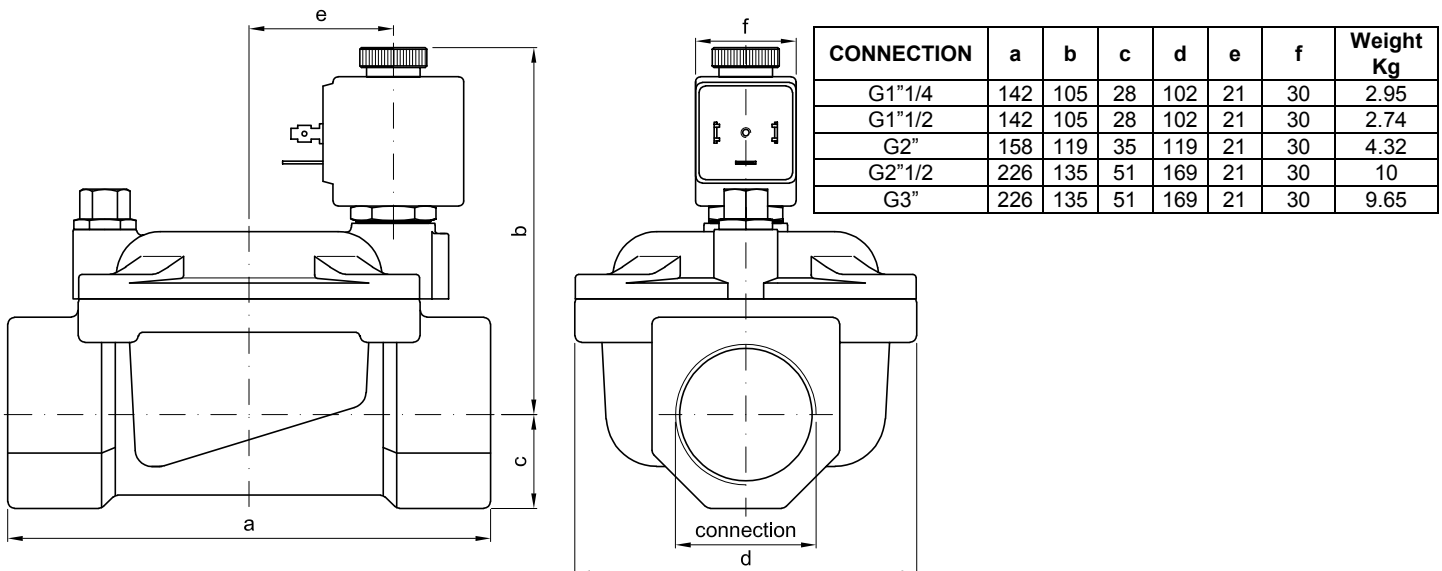



**DESCRIPTION**

Solenoid valve 2 way normally open with servo-assisted piston

**CONSTRUCTION**

Body and cover	Brass
Armature tube	Brass
Plunger and core	Stainless steel
Springs	Stainless steel
Piston	Brass
Piston ring	PTFE reinforced
Seal material	Main seal PTFE others FPM



**FEATURES**

- Minimum differential pressure 1 bar
- Maximum allowable pressure 40 bar
- Maximum fluid viscosity 25cSt (mm<sup>2</sup>/s)
- Ambient temperature : with class F coil -10°C +55°C  
with class H coil -10°C +80°C
- Preferred mounting position with vertical coil above

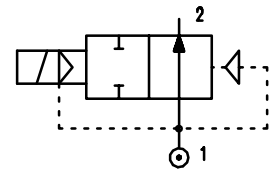

- OPTIONS :** Electroless nickel-plating  
Stainless steel armature tube

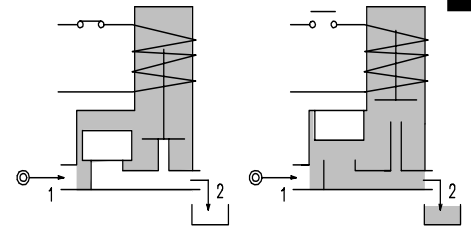

**4**

CODE ①	Connection G ISO 228	Orifice mm	KV m <sup>3</sup> /h	Differential pressure bar			Nominal power			Coil		Seal	Temp. range °C
				Min	Max		AC Inrush	VA Holding	DC Watt	Series	Width		
					AC	DC							
E219CV12///.....	3/8"	12	2	1	25	25	20	15	10	2	30	PTFE/FPM	-10 +130
E219DV12///.....	1/2"	12	2.2	1	25	25	20	15	10	2	30		

① Coil Example: E219DV12///20B FPM seal  
Coil 24V 50/60Hz

Maximum allowable leakage < 0.2 nL/h

COILS	Alternating Current ~50/60Hz Volt							Direct Current Volt			Electrical connection	Connectors
	12	24	48	110	220 230	240	380	12	24	48		
Series 2 Width 30 Code ①	20A	20B	20C	20D	20E	20F	20G	200	201	202	DIN 43650A	PG9 code 10349000

**DESCRIPTION**  
 Class F insulation  
 Voltage tolerance  
 AC +15% -10%  
 DC ± 10%  
 Protection class  
 IP65 with connector fitted  
 IP00 without connector  
 Continuous service ED100%

**OPTIONS**  
 Class H insulation  
 Cable attached  
 Special coil powers  
 Special coil voltages

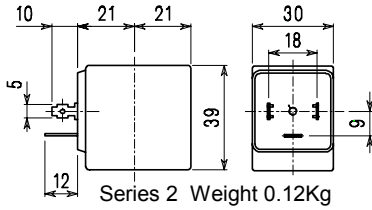

### SPARE PARTS LIST

1. Coil fixing nut
2. Coil
3. Seal assembly
4. Armature tube with core
5. Piston assembly

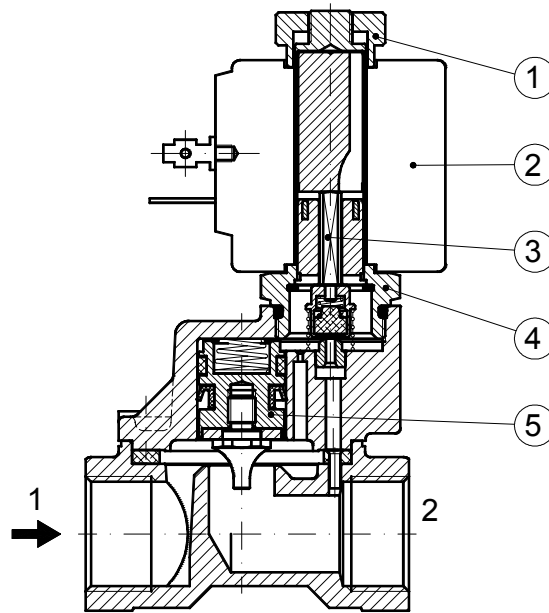

### OVERALL DIMENSION

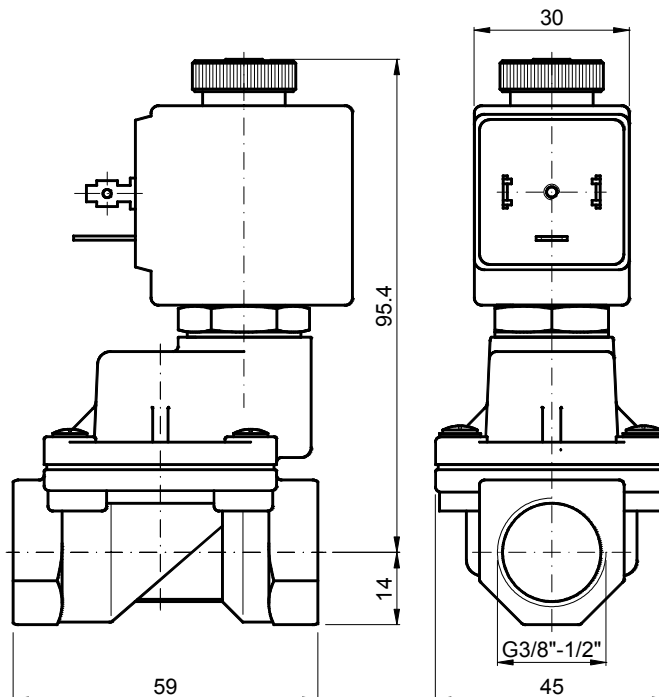

Weight 0.63 Kg

**DESCRIPTION**

Solenoid valve 2 way normally open in stainless steel AISI 316 with servoassisted diaphragm

**CONSTRUCTION**

Body and cover	Stainless steel
Armature tube	Stainless steel
Plunger and core	Stainless steel
Springs	Stainless steel
Seal material	NBR
	FPM
	EPDM



**FEATURES**

- Minimum differential pressure 0.15 bar
- Maximum allowable pressure 25 bar \*
- Maximum fluid viscosity 25cSt (mm<sup>2</sup>/s)
- Ambient temperature : with class F coil -10°C +55°C  
with class H coil -10°C +80°C
- Preferred mounting position with vertical coil above

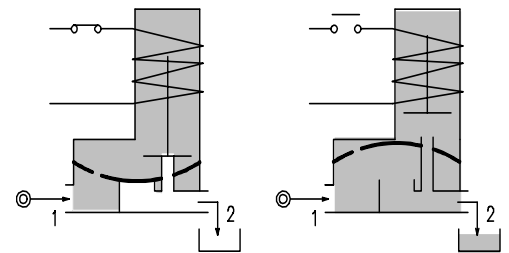
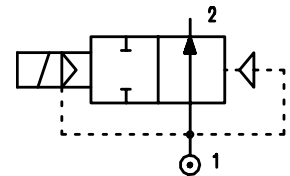

4

- OPTIONS :** Explosion proof coil according to ATEX - EExmII Series 7  
Food approval seal material  
Silver shading ring

CODE ① ②	Connection G ISO 228	Orifice mm	KV m <sup>3</sup> /h	Differential pressure bar			Nominal power			Coil		Seal ①	Temp. range °C
				Min	Max		AC Inrush	VA Holding	DC Watt	Series	Width		
					AC	DC							
E277C.....12///.....	3/8"	12	2.2	0.15	15	15	12	8	6.5	3	22	NBR=B EPDM=E FPM=V	-10 +90 <+140 -10 +130
E277D.....12///.....	1/2"	12	2.5	0.15	15	15							
E277E.....18///.....	3/4"	18	5.5	0.15	13	13							
E277F.....25///.....	1"	24	10.2	0.15	10	10							

- ① Seal
- ② Coil

Example: E277DB12///301 NBR seal  
Coil 24V DC

\* REMARK: The maximum allowable pressure PS for steam is 2,5bar (gauge pressure)

COIL	Alternating Current ~50/60Hz Volt							Direct Current Volt			Electrical connection	Connectors
	12	24	48	110	220 230	240	380	12	24	48		
Series 3 Width 22 Code ②	30A	30B	30C	30D	30E	30F	30G	300	301	302	DIN 46244	PG9 code 10348000

**DESCRIPTION**  
 Class F insulation  
 Voltage tolerance  
 AC +15% -10%  
 DC ± 10%  
 Protection class  
 IP65 with connector fitted  
 IP00 without connector  
 Continuous service ED100%

**OPTIONS**  
 Class H insulation  
 Cable attached  
 Special coil powers  
 Special coil voltages

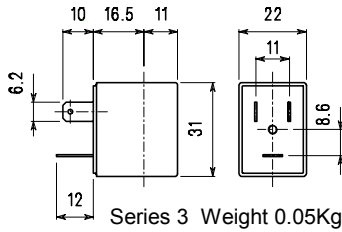

### SPARE PARTS LIST

1. Coil fixing nut
2. Coil
3. Seal assembly
4. Armature tube with core
5. Diaphragm assembly

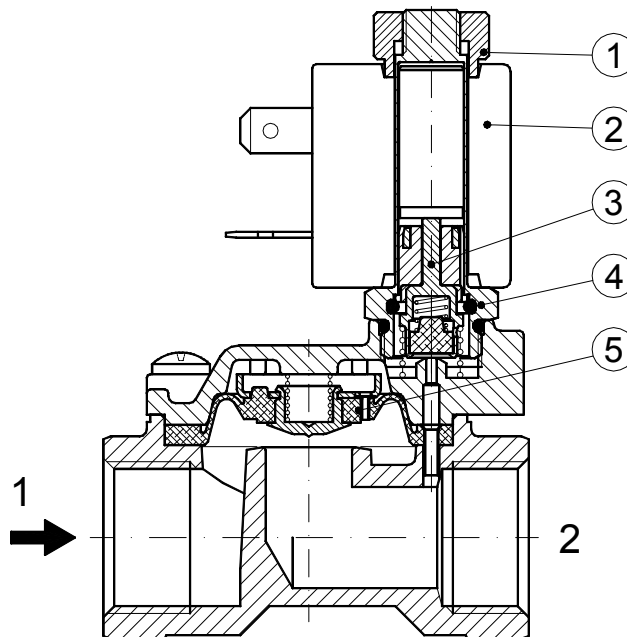

### OVERALL DIMENSION

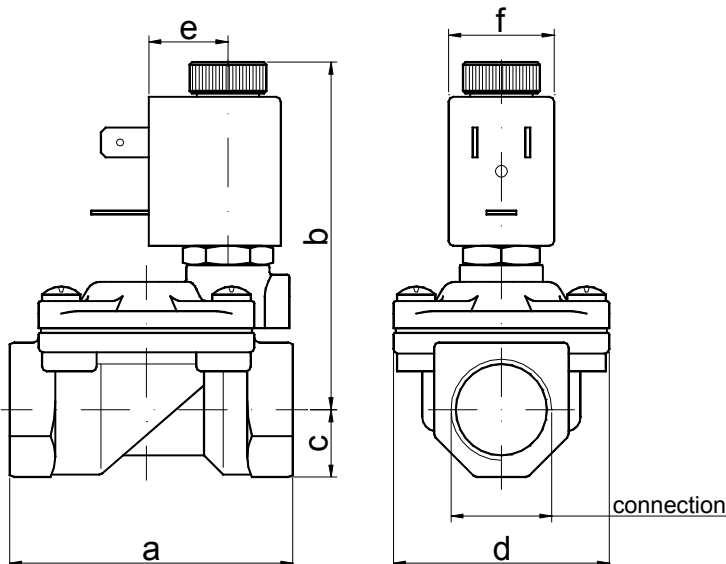

CONNECTION	a	b	c	d	Weight Kg
G3/8" Ø12	59	73	11	45	0.31
G1/2"	59	73	13	45	0.32
G3/4"	79	75	18	55	0.75
G1"	96	85	20	72	1.35

**DESCRIPTION**

Solenoid operated pinch valve with dry armature.  
 The tube is the only part in contact with the fluid.  
 The internal diameter determines the flow.  
 Elimination of dirt traps. Maximisation of valve coefficient.  
 Fluid flow can be bi-directional.  
 Use soft tube (not supply by us) hardness 50°Sh A ±3°



**CONSTRUCTION**

Body	Anodized aluminium
Yoke	Acetal copolymer
Armature tube	Nickel plated brass
Plunger and core	Stainless steel
Springs	Stainless steel
Flange	Stainless steel

**FEATURES**

Ambient temperature : -10°C +40°C  
 Maximum fluid viscosity 65 cSt (mm<sup>2</sup>/s)  
 Preferred mounting position with vertical coil above

**NOTE :** the right operating of the solenoid valve is bound by a correct choice of the soft tube

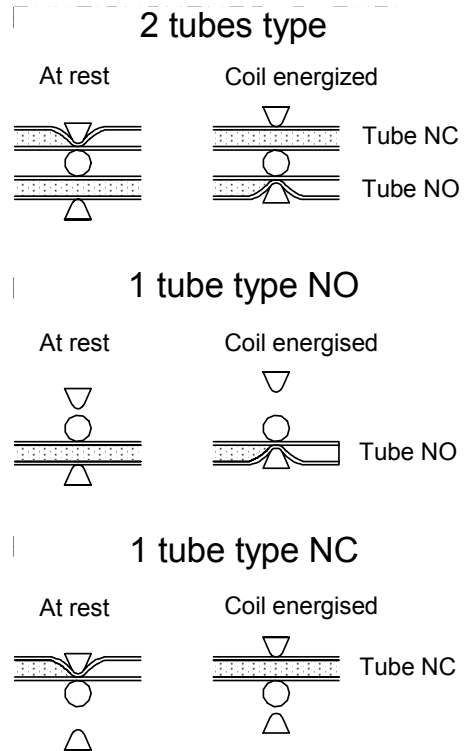

CODE	Tube		Pinch force grams	Version	Coil		Nominal Power Watt
	Øext. +0.2 0	Min thickness wall			Width	Series	
D730/30/..... <sup>①</sup>	3	0,7	250	2tubes 1NC-1NO	16	6	8
D710/30/.....	3	0,7	250	1tube NC	16	6	4
D720/30/.....	3	0,7	250	1tube NO	16	6	4

① Coil

Example: D730/30/60048  
 Version with 2 tubes 12V DC 8W ED25%

COIL	Direct Current				Electrical connection	Connector
	12V		24V			
	4W	8W	4W	8W		
Series 6 CODE Width 16 ①	60014	60048	60114	60148	AMP 2.8X0.5	PG7 10348040

**DESCRIPTION**  
 Class F insulation  
 Voltage tolerance  $\pm 5\%$   
 Protection class  
 IP65 with connector fitted  
 IP00 without connector  
 Continuous service ED100%

**OPTIONS**  
 Cable attached  
 Special coil powers  
 Special coil voltages

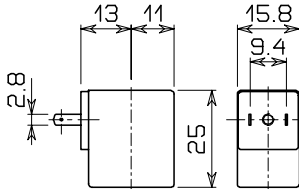

Series 6 Weight 0.02Kg

### SPARE PARTS LIST

1. Coil fixing nut
2. Coil

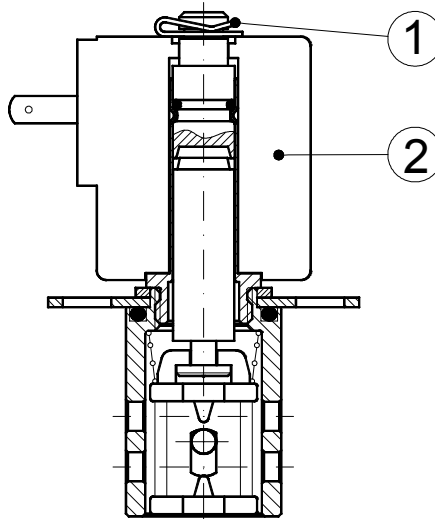

### OVERALL DIMENSION

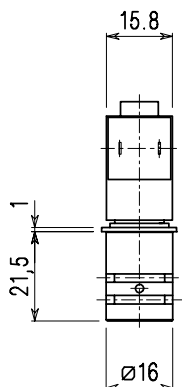
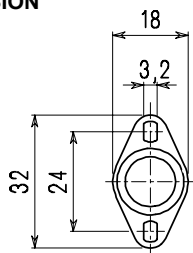

D730  
2 tubes

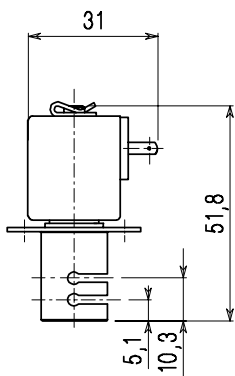

D720  
1 tube NO

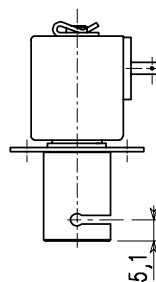

D710  
1 tube NC

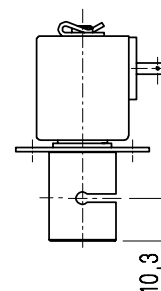

Weight = 0.04 Kg

**DESCRIPTION**

Solenoid pilot 2 way normally closed. Tube Ø10.

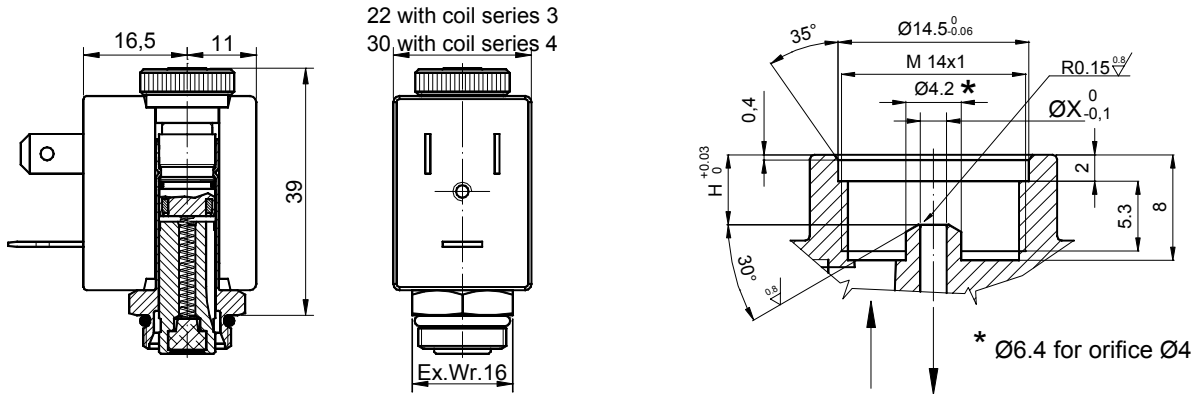

CODE		Ø X mm	H mm	Differential pressure bar			Nominal power			Coil		Seal	Temp. range °C
Brass Tube	S.Steel Tube			Min	Max		AC Inrush	VA Holding	DC Watt	Series	Width		
					AC	DC							
E510 .....	E512.....	1.2	5	0	25	25	12	8	6.5	3	22	NBR=B EPDM=E FPM=V	-10 +90 <140 -10 +130
		1.5	5.1	0	16	16							
		2	5.2	0	12	10							
		2.5	5.4	0	8	5.5							
E510...40	E512...40	4	5.6	0	4	1.5	15	11	5	4	30	NBR=B EPDM=E FPM=V	-10 +90 <140 -10 +130
E510 .....	E512.....	2	5.2	0	25	15							
		2.5	5.4	0	16	8							
E510...40	E512...40	3.1	5.5	0	8	4	15	11	5	4	30	NBR=B EPDM=E FPM=V	-10 +90 <140 -10 +130
		4	5.6	0	5	2.5							

**DESCRIPTION**

Solenoid pilot 2 way normally open. Tube Ø10.

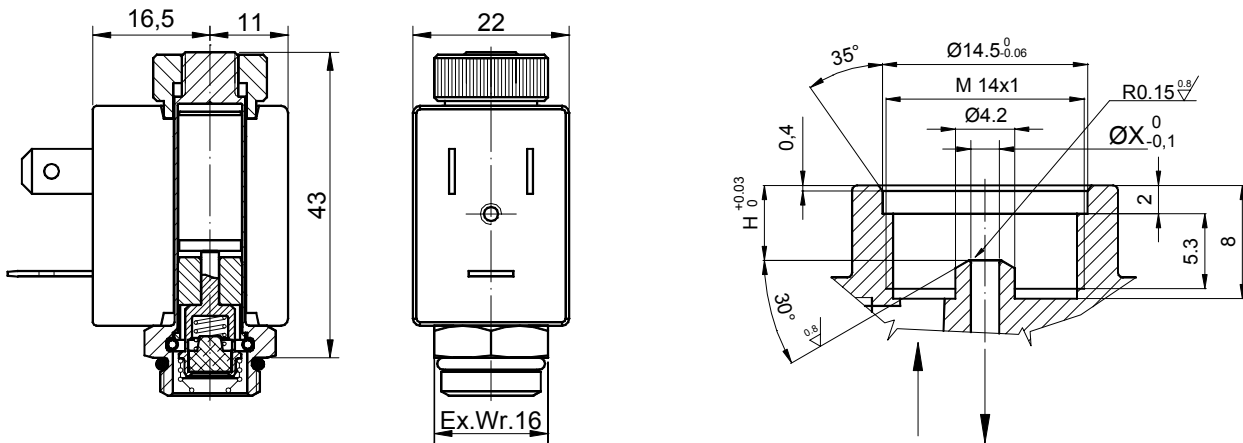

CODE		Ø X mm	H mm	Differential pressure bar			Nominal power			Coil		Seal	Temp. range °C
Brass Tube	S.Steel Tube			Min	Max		AC Inrush	VA Holding	DC Watt	Series	Width		
					AC	DC							
E520 .....	E522.....	1.2	5	0	19	19	12	8	6.5	3	22	NBR=B EPDM=E FPM=V	-10 +90 <+140 -10 +130
		1.5	5.1	0	14	14							
		2	5.2	0	8	8							
		2.5	5.4	0	4.5	4.5							
E520...40	E522...40	3.1	5.5	0	2.5	2.5	12	8	6.5	3	22	NBR=B EPDM=E FPM=V	-10 +90 <+140 -10 +130
		4	5.6	0	2.5	2.5							

**DESCRIPTION**

Solenoid pilot 3 way normally closed. Tube Ø10.

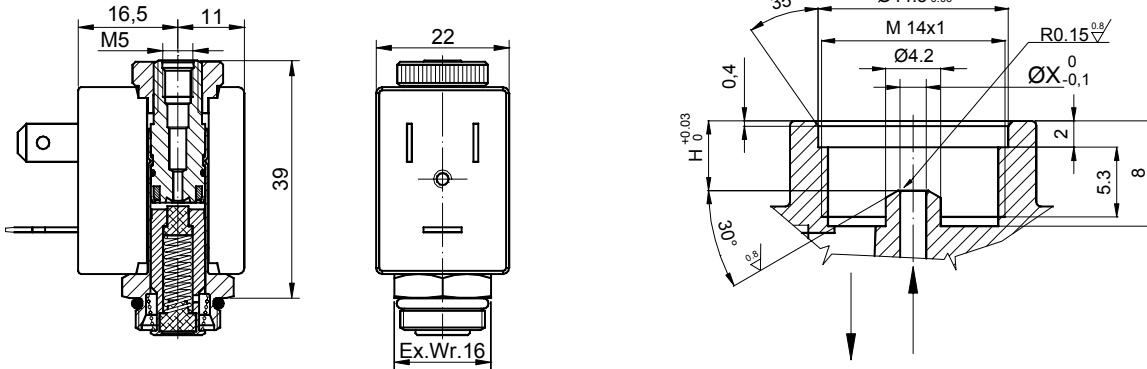

Hosetail exhaust on request

CODE		Ø X mm	Ø exh. mm	H mm	Differential pressure bar			Nominal power			Coil		Seal	Temp. range °C
Brass Tube	S.Steel Tube				Min	Max		AC Inrush	VA Holding	DC Watt	Series	Width		
						AC	DC							
E530 .....	E532.....	1.2	1.5	5	0	15	15	12	8	6.5	3	22	NBR=B EPDM=E FPM=V	-10 +90 <140 -10 +130
		1.5	1.5	5.1	0	10	10							
		2	1.7	5.2	0	6	6							

**DESCRIPTION**

Solenoid pilot 3 way normally open. Tube Ø10.

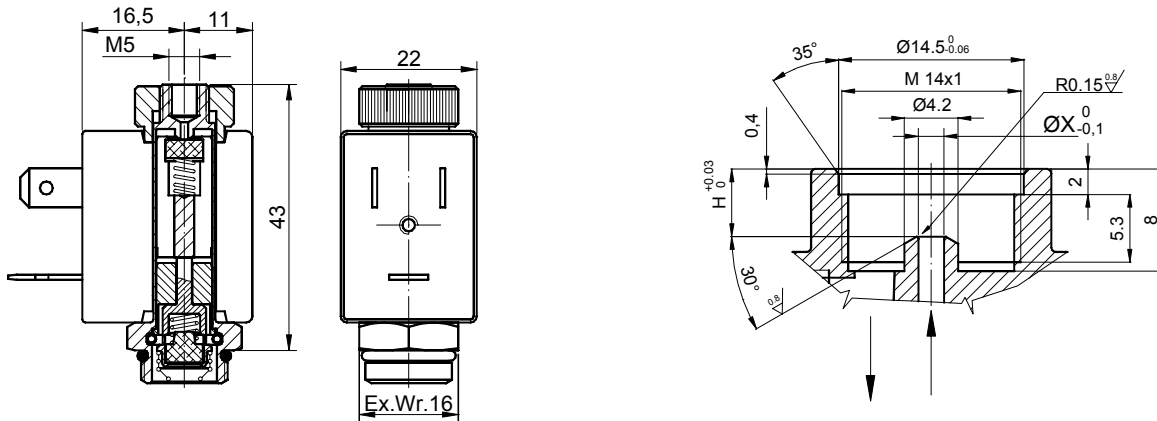

CODE		Ø X mm	Ø exh. mm	H mm	Differential pressure bar			Nominal power			Coil		Seal	Temp. range °C
Brass Tube	S.Steel Tube				Min	Max		AC Inrush	VA Holding	DC Watt	Series	Width		
						AC	DC							
E540 .....		1.2	1.5	5	0	12	8	12	8	6.5	3	22	NBR=B EPDM=E FPM=V	-10 +90 <140 -10 +130
		1.5	1.5	5.1	0	9	6							



**DESCRIPTION**

Solenoid pilot 2 way normally closed. Tube Ø10 flange fixing.

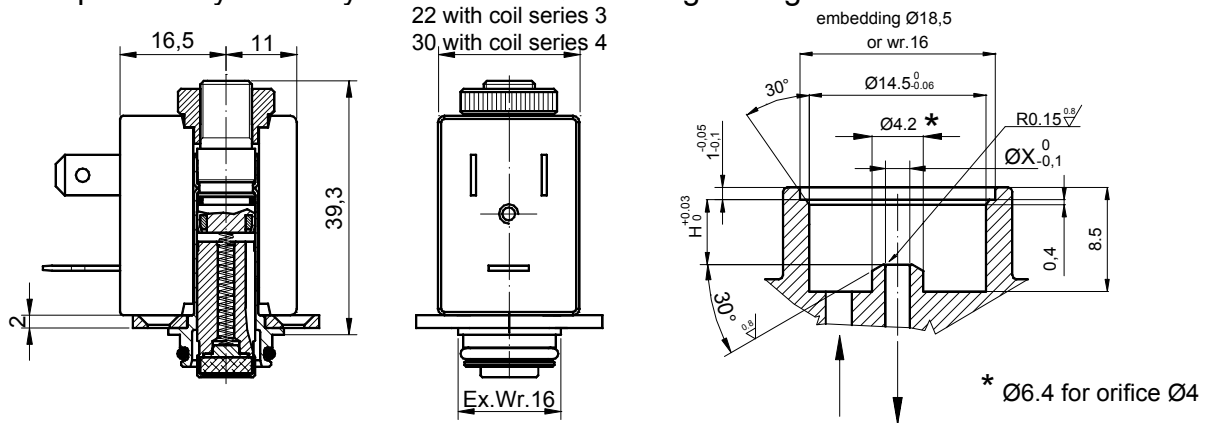

CODE		Ø X mm	H mm	Differential pressure bar			Nominal power			Coil		Seal	Temp. range °C
Brass Tube	S.Steel Tube			Min	Max		AC Inrush	VA Holding	DC Watt	Series	Width		
					AC	DC							
E570 .....	E572.....	1.2	5	0	25	25	12	8	6.5	3	22	NBR=B EPDM=E FPM=V	-10 +90 <140 -10 +130
		1.5	5.1	0	16	16							
		2	5.2	0	12	10							
		2.5	5.4	0	8	5.5							
E570...40	E572...40	4	5.6	0	4	1.5	15	11	5	4	30		
E570 .....	E572.....	2	5.2	0	25	15							
		2.5	5.4	0	16	8							
		3.1	5.5	0	8	4							
E570...40	E572...40	4	5.6	0	5	2.5							

**DESCRIPTION**

Solenoid pilot 2 way normally open. Tube Ø10 flange fixing.

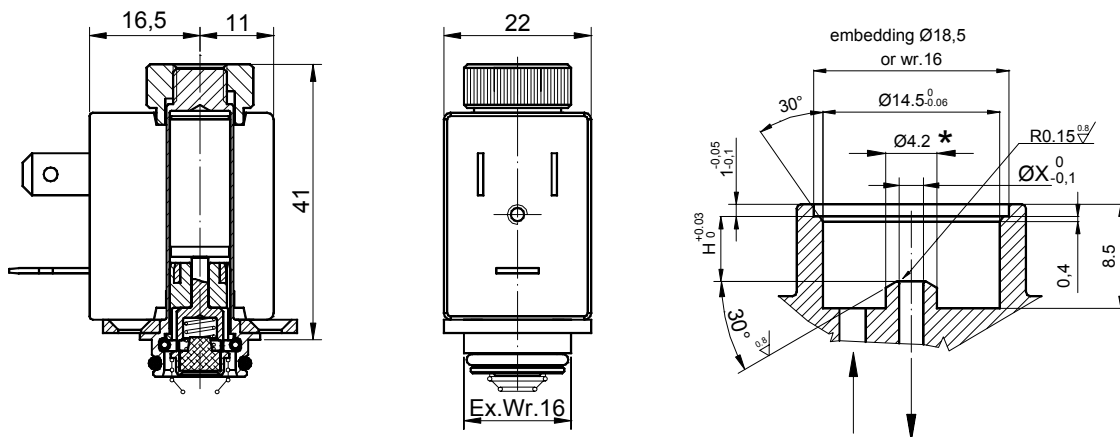

CODE		Ø X mm	H mm	Differential pressure bar			Nominal power			Coil		Seal	Temp. range °C
Brass Tube	S.Steel Tube			Min	Max		AC Inrush	VA Holding	DC Watt	Series	Width		
					AC	DC							
E575 .....		1.2	5	0	19	19	12	8	6.5	3	22	NBR=B EPDM=E FPM=V	-10 +90 <+140 -10 +130
		1.5	5.1	0	14	14							
		2	5.2	0	8	8							
		2.5	5.4	0	4.5	4.5							
		3.1	5.5	0	2.5	2.5							

**DESCRIPTION**

Solenoid pilot 3 way normally closed. Tube Ø10 flange fixing.

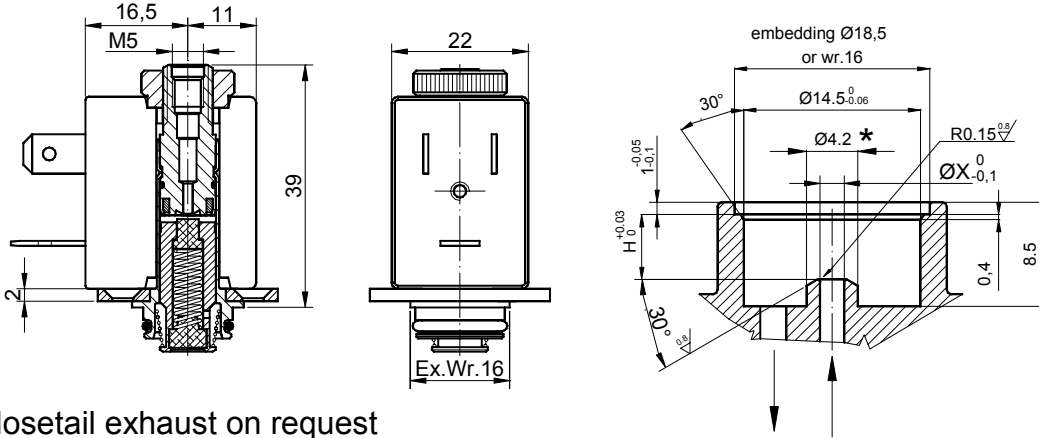

Hosetail exhaust on request

CODE		Ø X mm	Ø exh. mm	H mm	Differential pressure bar			Nominal power			Coil		Seal	Temp. Range °C
Brass Tube	S.Steel Tube				Min	Max		AC Inrush	VA Holding	DC Watt	Series	Width		
						AC	DC							
E580 .....	E582.....	1.2	1.5	5	0	15	15	12	8	6.5	3	22	NBR=B EPDM=E FPM=V	-10 +90 <140 -10 +130
		1.5	1.5	5.1	0	10	10							
		2	1.7	5.2	0	6	6							

**DESCRIPTION**

Solenoid pilot 3 way normally open. Tube Ø10 flange fixing.

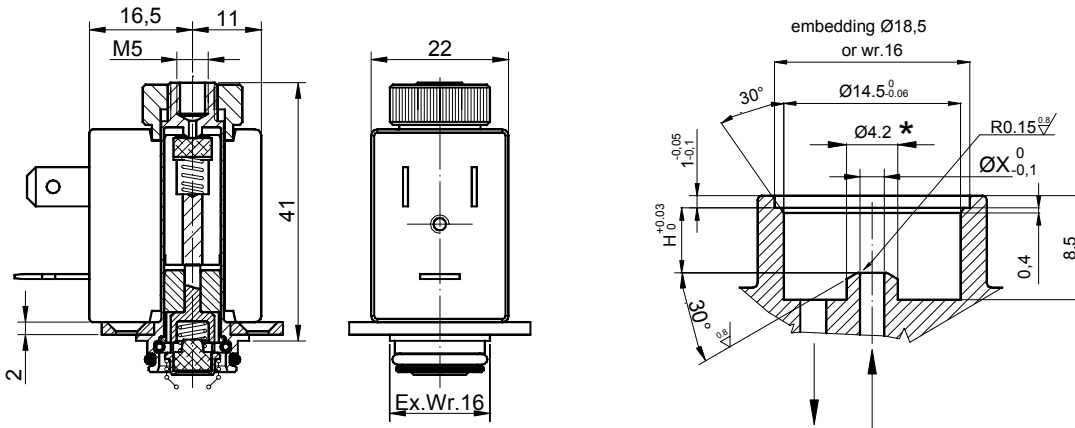

CODE		Ø X mm	Ø exh. mm	H mm	Differential pressure bar			Nominal power			Coil		Seal	Temp. range °C
Brass Tube	S.Steel Tube				Min	Max		AC Inrush	VA Holding	DC Watt	Series	Width		
						AC	DC							
E585 .....		1.2	1.5	5	0	12	8	12	8	6.5	3	22	NBR=B EPDM=E FPM=V	-10 +90 <140 -10 +130
		1.5	1.5	5.1	0	9	6							

**DESCRIPTION**

Solenoid pilot 2 way normally closed. Tube Ø13.

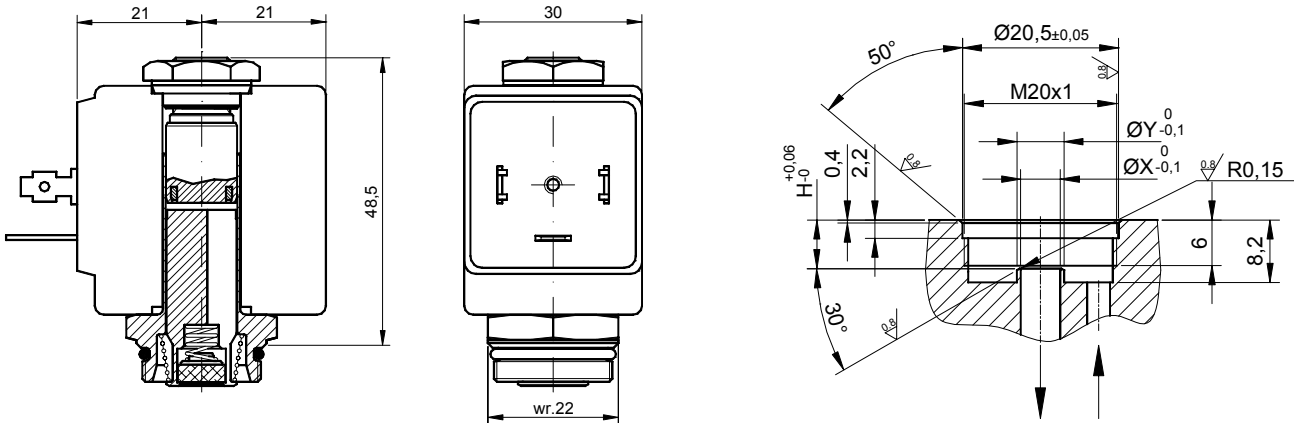

Available version for X=Ø6.4mm

CODE S.Steel Tube	Ø X mm	H mm	ØY mm	Differential pressure bar			Nominal power			Coil		Seal	Temp. range °C
				Min	Max		AC Inrush	VA Holding	DC Watt	Series	Width		
					AC	DC							
E610.....	1.5	6.2	4.2	0	30	26	20	15	10	2	30	NBR=B EPDM=E FPM=V	-10 +90 <+140 -10 +130
	2	6.2	4.2	0	22	20							
	2.5	6.2	4.2	0	16	14							
	3.5	6.2	6.2	0	10	8							
	4.5	6.4	6.2	0	6.5	3.5							
5.2	6.4	6.2	0	4	1.8								

**DESCRIPTION**

Solenoid pilot 2 way normally open. Tube Ø13.

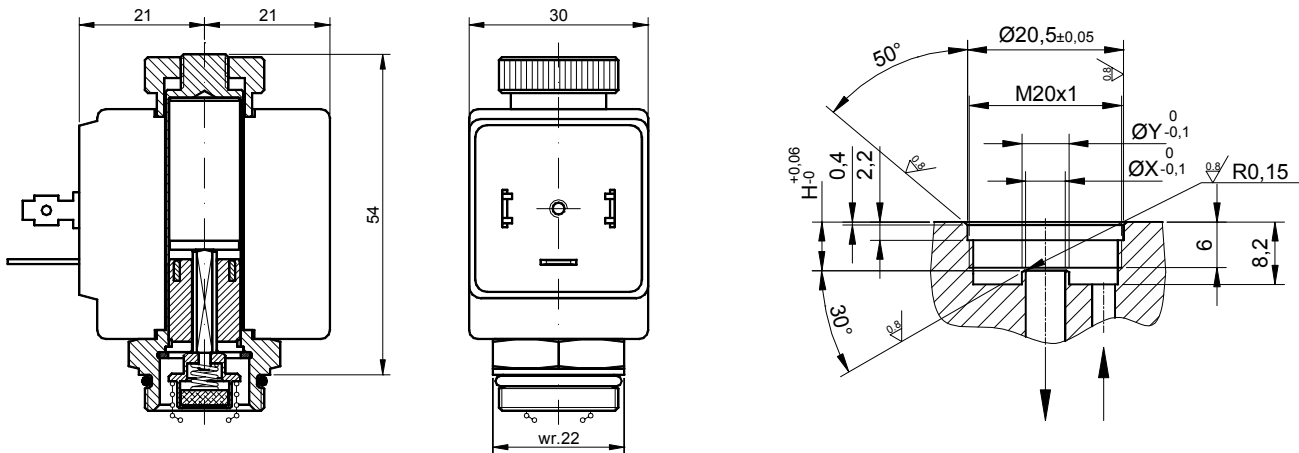

CODE		Ø X mm	H mm	ØY mm	Differential pressure bar			Nominal power			Coil		Seal	Temp. range °C
S.Steel Tube	Brass Tube				Min	Max		AC Inrush	VA Holding	DC Watt	Series	Width		
						AC	DC							
E620 .....	E622 .....	1.5	6.2	4.2	0	23	23	20	15	10	2	30	NBR=B EPDM=E FPM=V	-10 +90 <+140 -10 +130
		2	6.2	4.2	0	17	17							
		2.5	6.2	4.2	0	12	12							
		3.5	6.2	6.2	0	7	4 ③							
		4.5	6.4	6.2	0	4.5	3 ③							
5.2	6.4	6.2	0	3	2.2 ③									

③ Only for the DC on the orifices Ø 3,5 - 4,5 - 5,2 the code is D620 or D622

ØX must be specified in the order

**DESCRIPTION**

Solenoid pilot 3 way normally closed. Tube Ø13.

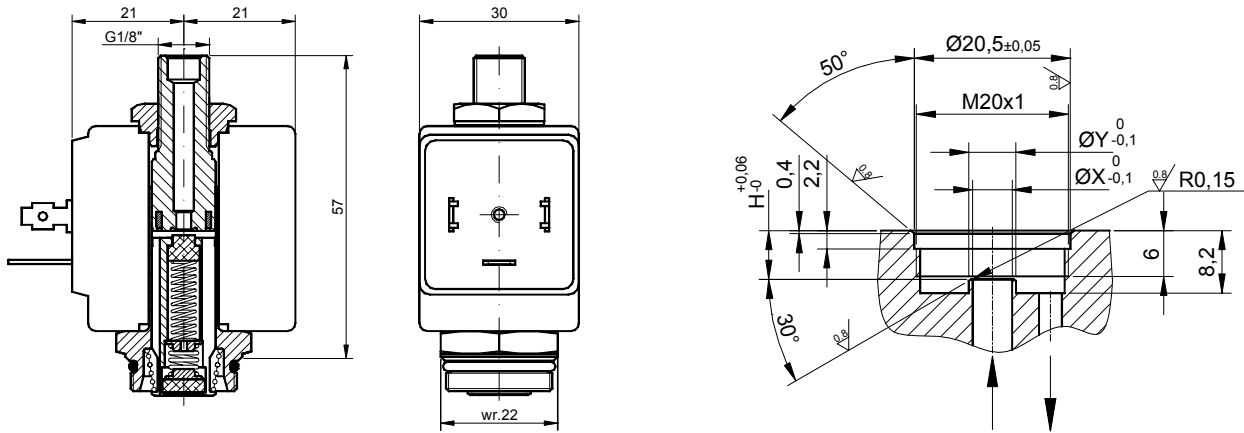

CODE S.Steel Tube	Ø X mm	H mm	Ø exh. mm	ØY mm	Differential pressure bar			Nominal power			Coil		Seal	Temp. range °C
					Min	Max		AC Inrush	VA Holding	DC Watt	Series	Width		
						AC	DC							
E630 .....	1.5	6.2	2.4	4.2	0	20	20	20	15	10	2	30	NBR=B EPDM=E FPM=V	-10 +90 <140 -10 +130
	2	6.2	2.4	4.2	0	13	13							
	2.5	6.2	2.4	4.2	0	10	10							

**DESCRIPTION**

Solenoid pilot 2 way normally closed. Tube Ø13 flange fixing.

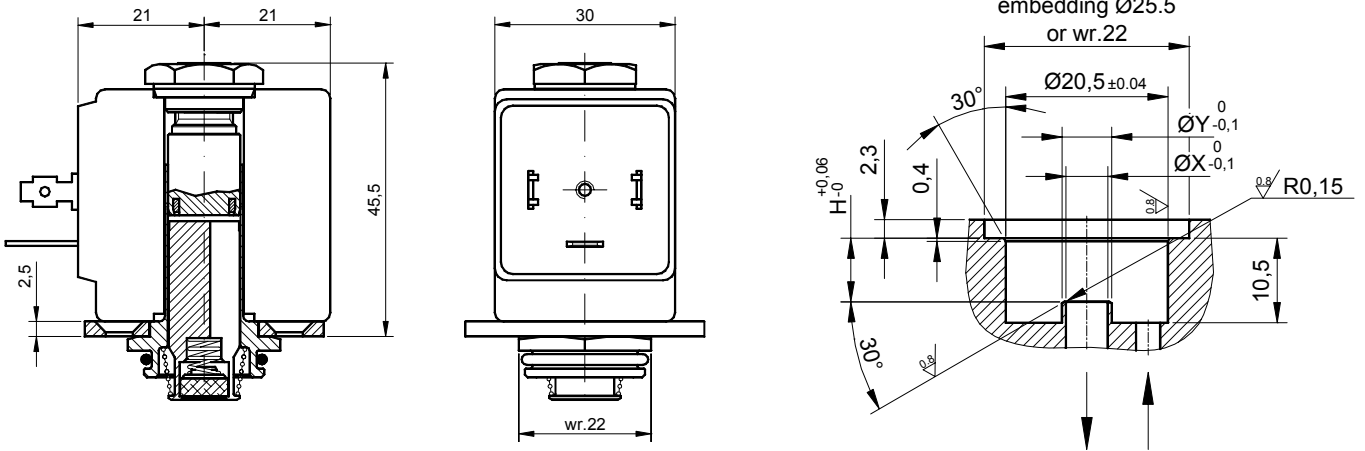

CODE S.Steel Tube	Ø X mm	H mm	ØY mm	Differential pressure bar			Nominal power			Coil		Seal	Temp. range °C
				Min	Max		AC Inrush	VA Holding	DC Watt	Series	Width		
					AC	DC							
E670.....	1.5	7.7	4.2	0	30	26	20	15	10	2	30	NBR=B EPDM=E FPM=V	-10 +90 <+140 -10 +130
	2	7.7	4.2	0	22	20							
	2.5	7.7	4.2	0	16	14							
	3.5	7.7	6.2	0	10	8							
	4.5	7.9	6.2	0	6.5	3.5							
5.2	7.9	6.2	0	4	1.8								



### DESCRIPTION

Encapsulated coil incorporating the magnetic circuit.  
 Fixing by means of a central nut.  
 Electrical connection according to DIN 43650 A.



### CONSTRUCTION

Encapsulation:  
 Class F                      Fibre-glass Nylon  
 Class H                      Fibre-glass Polyarylamide  
 Magnetic circuit:        Zinc-plated steel  
 Windings:                Copper covered with class H insulation

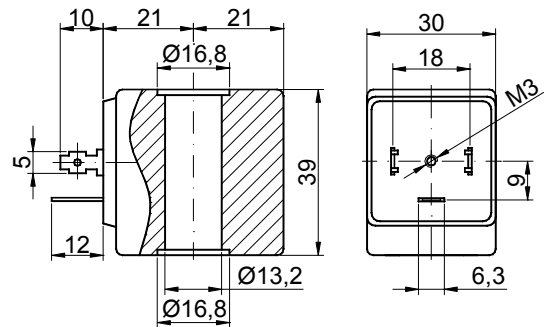

**OPTIONS :** Electrical connection through cable  
 Special powers and voltages  
 Self-extinguish

Certified version



CODE		Alternating Current Frequency 50/60Hz Voltage Volt	Direct Current Voltage Volt	Power ①		Voltage tolerance		Connector	Service ED
Insulation class F	Insulation class H			Alternating Current VA	Direct Current Watt	Alternating Current	Direct Current		
20A	22A	12	---	15	10	+15%	±10%	10349000	100%
20B	22B	24	---						
20C	22C	48	---						
20D	22D	110	---						
20E	22E	220/230	---			-10%	10349060		
20F	22F	240	---						
20G	22G	380	---			10349001			
200	220	---	12						
201	221	---	24						
202	222	---	48						
/	U25D	120V 60Hz	cRU <sup>®</sup> US						
/	U25E	230V 60Hz							

① Considering nominal voltage and an ambient temperature of 20°C





## DESCRIPTION

Encapsulated coil incorporating the magnetic circuit.  
 Fixing by means of central nut.  
 Electrical connection DIN 43650 B.



## CONSTRUCTION

Encapsulation:

Class F                      Fibre-glass Nylon

Class H                      Fibre-glass Polyarylamide

Magnetic circuit:        Zinc-plated steel

Windings:                 Copper covered with class H insulation

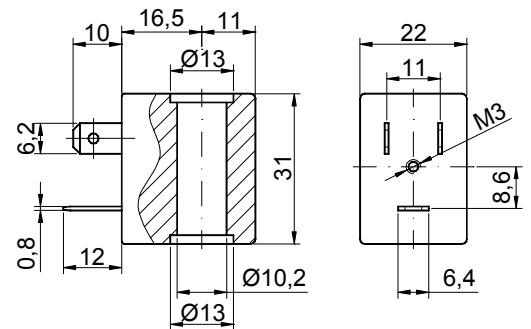

**OPTIONS :** Electrical connection through cable  
 Special coil powers  
 Special coil voltages  
 Self-extinguish

Certified versions



CODE		Alternating Current Frequency 50/60Hz Voltage Volt	Direct Current Voltage Volt	Power ①		Voltage tolerance		Connector	Service ED
Insulation class F	Insulation class H			Alternating Current VA	Direct Current Watt	Alternating Current	Direct Current		
30A	32A	12	---	8	6.5	+15%	±10%	10348000	100%
30B	32B	24	---						
30C	32C	48	---						
30D	32D	110	---						
30E	32E	220/230	---						
30F	32F	240	---						
30G	32G	380	---						
300	320	---	12						
301	321	---	24						
302	322	---	48						
/	U35D	120V 60Hz	UL US						
/	U35E	230V 60Hz							
/	V32E	220/230	VDE						

7

① Considering nominal voltage and an ambient temperature of 20°C



### DESCRIPTION

Encapsulated coil incorporating the magnetic circuit.  
 Fixing by means of a central nut.  
 Electrical connection according to DIN 43650 A.



### CONSTRUCTION

Encapsulation:

Class F                      Fibre-glass Nylon

Class H                      Fibre-glass Polyarylamide

Magnetic circuit:        Zinc-plated steel

Windings:                Copper covered with  
 class H insulation

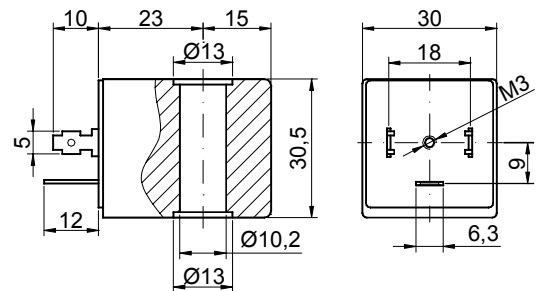

**OPTIONS :** Electrical connection through cable  
 Special powers and voltages  
 Self-extinguish

CODE		Alternating Current Frequency 50/60Hz Voltage Volt	Direct Current Voltage Volt	Power ①		Voltage tolerance		Connector	Service ED
Insulation class F	Insulation class H			Alternating Current VA	Direct Current Watt	Alternating Current	Direct Current		
40A	42A	12	---	11	5	+15%	±10%	10349000	100%
40B	42B	24	---						
40C	42C	48	---						
40D	42D	110	---			-10%			
40E	42E	220/230	---						
40F	42F	240	---						
40G	42G	380	---						
400	420	---	12						
401	421	---	24						
402	422	---	48						

① Considering nominal voltage and an ambient temperature of 20°C



### DESCRIPTION

Encapsulated coil incorporating the magnetic circuit.  
 Fixing by means of a central nut.  
 Electrical connection according to DIN 43650 A.



### CONSTRUCTION

Encapsulation:  
 Class H Fibre-glass Polyarylamide

Magnetic circuit: Zinc-plated steel  
 Windings: Copper covered with class H insulation

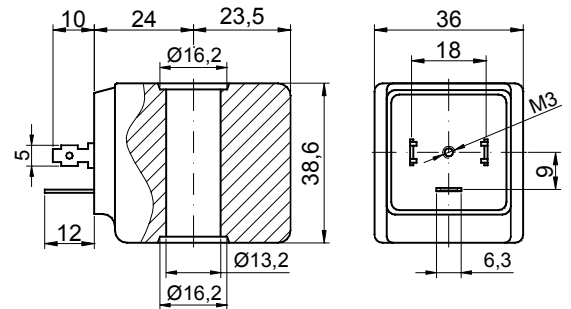

**OPTIONS :** Electrical connection through cable  
 Special coil powers  
 Special coil voltages  
 Self-extinguish

CODE Insulation class H	Alternating Current Frequency 50/60Hz Voltage Volt	Direct Current Voltage Volt	Power ①		Voltage tolerance		Connector	Service ED
			Alternating Current VA	Direct Current Watt	Alternating Current	Direct Current		
52A	12	---	30	27	+15%	±10%	10349000	100%
52B	24	---						
52C	48	---						
52D	110	---						
52E	220/230	---						
52F	240	---						
52G	380	---						
520	---	12	-10%			10349001		
521	---	24						
522	---	48						10349060

7

① Considering nominal voltage and an ambient temperature of 20°C



### DESCRIPTION

Encapsulated coil incorporating magnetic circuit.  
 Fixing by means of a central nut.  
 Electrical connection according to AMP 2.8x0.5 .



### CONSTRUCTION

Encapsulation:  
 Class F                      Fibre-glass Nylon

Magnetic circuit:          Zinc-plated steel

Windings:                    Copper covered with  
 class H insulation

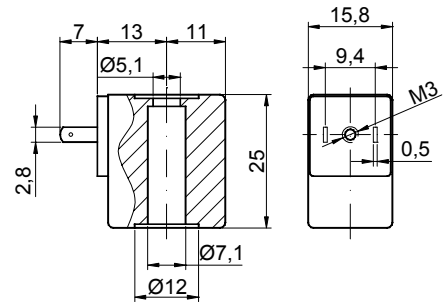

**OPTIONS :** Electrical connection through cable  
 Special coil powers  
 Special coil voltages  
 Self-extinguish

CODE Insulation Class F	Direct Current Voltage Volt	Power ① Direct Current Watt	Voltage tolerance	Connector	Service ED
60014	12	4	±5%	10348040	100%
60048	12	8			25%
60114	24	4			100%
60148	24	8			25%
60012	12	2			100%
60112	24	2			100%

① Considering nominal voltage and an ambient temperature of 20°C





## DESCRIPTION

Encapsulated coil with self-extinguish nylon and incorporating a thermal resistor and a thermal fuse. This design prevents any problems of overheating or sparking occurring making it particularly suitable for use in potentially explosive ambient.



## COSTRUZIONE

Encapsulation: Self-extinguish Nylon  
 Class F  
 Magnetic circuit: Zinc-plated steel  
 Windings: Copper covered with class H insulation

## ELECTRICAL CONNECTION

3-core cable 300 cm.

## AMBIENT TEMPERATURE

-20°C +40°C

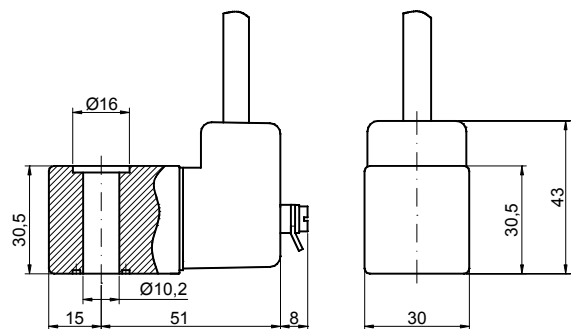

## CERTIFICATE

Conforms with the European standards for the manufacturing of electrical components for use in potentially explosive atmospheres.

**EN 50014-1997+ A1...A2**

**E50025-1997, IEC 60079-18:2002**

**European Community Standard 97/9/CE**

**EEx m II T4 INERIS 06ATEX0002X  
 CE 0080 Ex II 2 GD**

**7**

CODE	VOLTAGE	FREQUENCY	POWER ①
75BD	24	50-60 Hz	5.3 W
75CD	48	50-60 Hz	5.3 W
75DD	110	50-60 Hz	5.2 W
75ED	230	50-60 Hz	5.2 W
751D	24 DC	---	5.4 W

T5 and T6 temperature class version available on request

① Considering nominal voltage and an ambient temperature of 20°C



## SINGLE BASE

Code:  
B01/340/M5

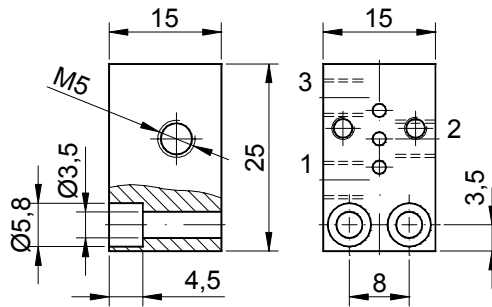

## MULTIPLE BASES

Code:  
B...../340/M5

N° PLACES

B...../340/R4

N° PLACES

\* = M5 Thread

\* = quick connection  
for pipes  $\varnothing_{ext}$  4

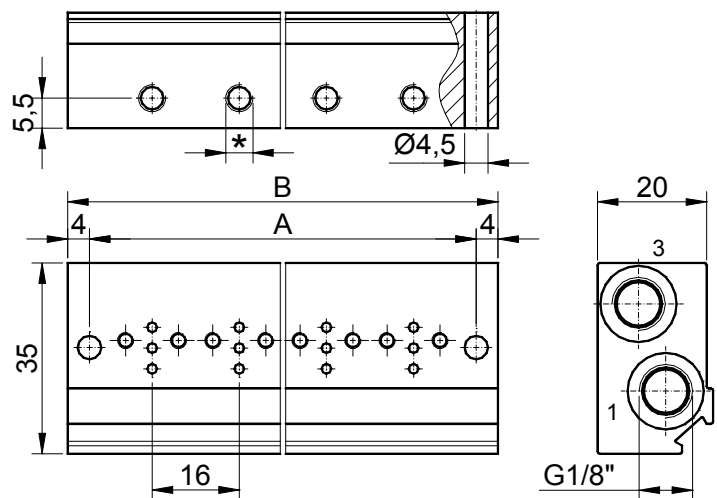

N° PLACES	2	3	4	5	6	7	8	9	10
A	39	55	71	87	103	119	135	151	167
B	47	63	79	95	111	127	143	159	175

## BLANKING PLATE

Code:  
PC/340

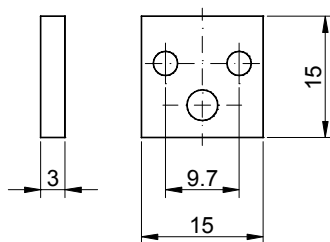

## REVERSING PLATE FOR N.O. (341)

Code:  
PA/340

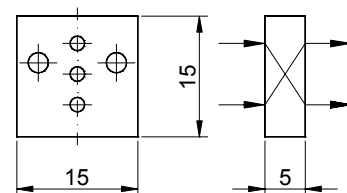

## SINGLE BASE

Code:  
B01/345/M5

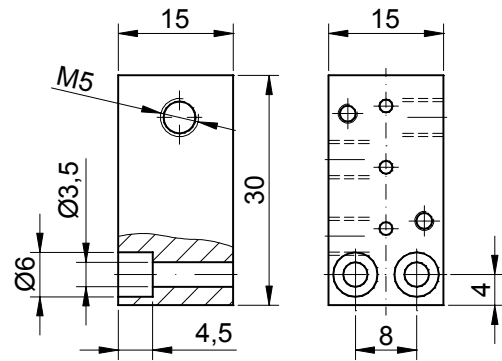

## MULTIPLE BASES

Code:  
B...../345/M5

N° PLACES

B...../345/R4

N° PLACES

\* = M5 Thread

\* = quick connection  
for pipes Øext 4

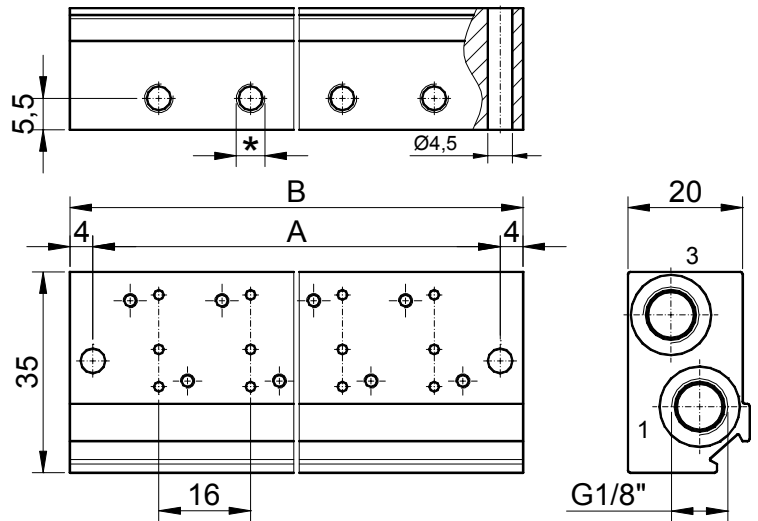

N° PLACES	2	3	4	5	6	7	8	9	10
A	39	55	71	87	103	119	135	151	167
B	47	63	79	95	111	127	143	159	175

## BLANKING PLATE

Code:  
PC/345

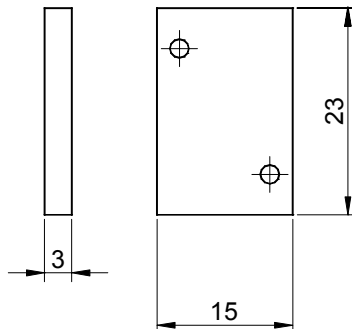

## Connector code 103490...

DIN 43650 Form A connector

Contacts distance : 18 mm  
 Protection class : IP 65  
 Working temperature : -40°C +90°C  
 Fixing method : M3 central screw  
 Gland size : PG9 cable Ø 6-8mm  
 code 10349000 (n°2 poles+earth)

PG11 cable Ø 8-10mm  
 code 10349001 (n°2 poles+earth)

On request : PG9 cable Ø 6-8mm  
 code 10349060 (n°3 poles+earth)

Weight 0.023Kg

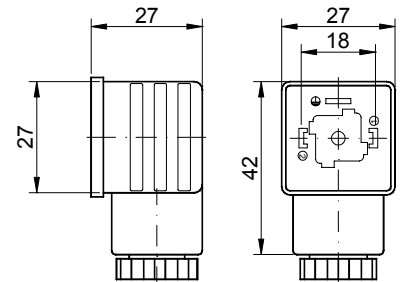

## Connector code 10348000

DIN 46244 Form B (43650 B) connector

Contacts distance : 11 mm  
 Protection class : IP 65  
 Working temperature : -40°C +90°C  
 Fixing method : M3 central screw  
 Gland size : PG9 cable Ø 6-8mm

n°2 poles+earth

Weight 0.019Kg

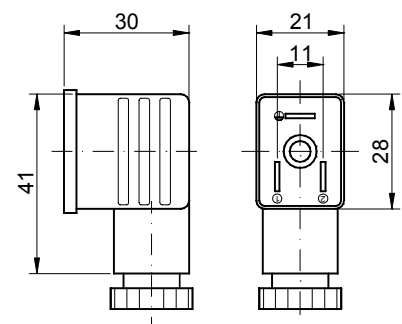

**Connector code 10348040**

AMP 2,8x0,5 connector

Contacts distance : 9,4 mm  
Protection class : IP 65  
Working temperature : -40°C +90°C  
Fixing method : M3 central screw  
Gland size : PG7 cable Ø 4-6mm

n°2 poles+earth

Weight 0.010Kg

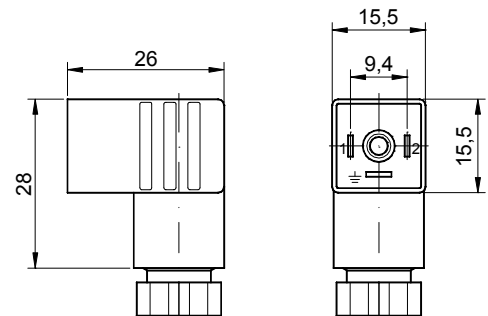
**Connector code 10348060**

DIN 43650 Form C connector

Contacts distance : 8 mm  
Protection class : IP 65  
Working temperature : -40°C +90°C  
Fixing method : M2,5 central screw  
Gland size : PG7 cable Ø 4-6mm

n°2 poles+earth

Weight 0.010Kg

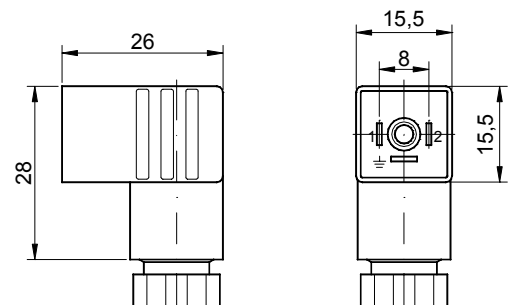

**Fixing kit for solenoid valves series 350-351**  
**Code 11255000**

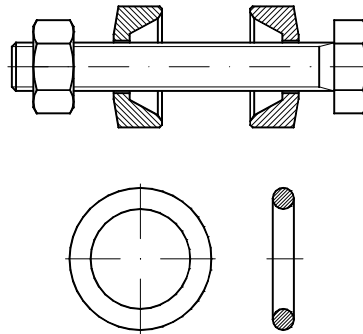

**Fixing flange for pilots series 570-580**  
**Code 11092000**

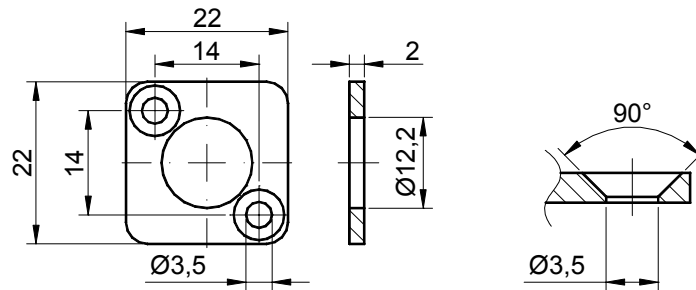

**Fixing flange for pilots series 570-580**  
**Code 10984000**

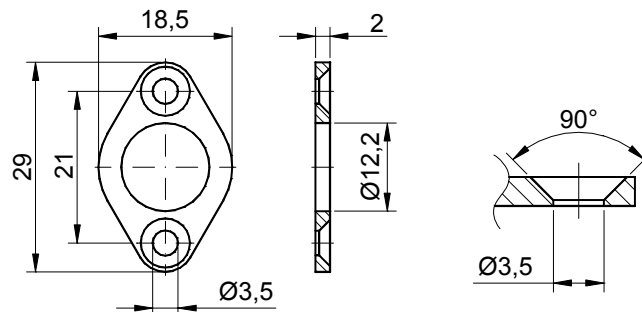

**Fixing flange for pilots series 670-680**  
**Code 11260000**

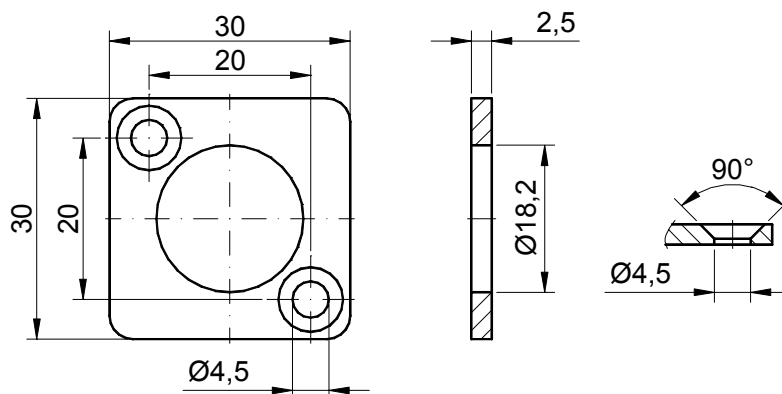

## Wet-proof coil fixing nut

For coil series 3 and 4 (solenoid valves 2/2NC)

Code 11003000

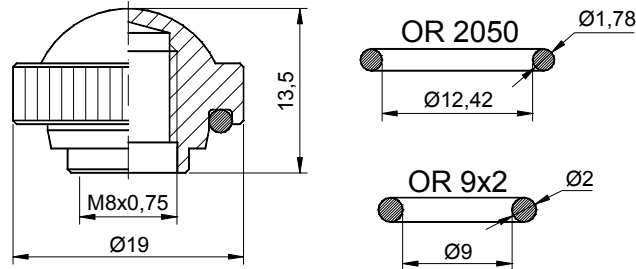

For coil series 3 and 4 (solenoid valves 3/2NC)

Code 11586N00

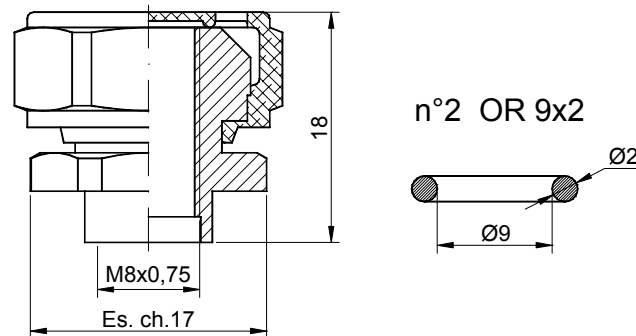

For coil series 3 and 4 (solenoid valves 3/2NO)

Code 11587N00

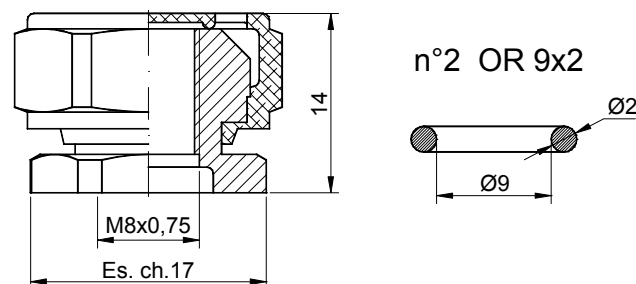

For coil series 2 and 5 (solenoid valves 2/2NC)

Code 11002000

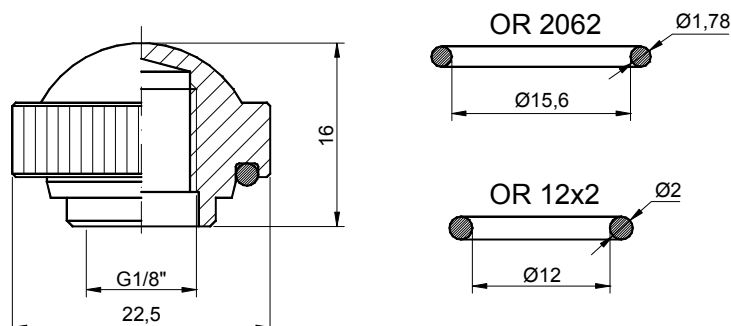





**FILTER BALL VALVE****Code 11322000 1/2"-1/2"****Code 11322010 1/2"-3/8"****CONSTRUCTION**

Body	Brass chromium plated
Actuator	Nylon 6.6
Filter	Stainless steel
O-ring	NBR

**FEATURES**

Connections 1/2"-1/2" and 1/2"-3/8"

Maximum working temperature : Water +70°C  
Air +90°C



## DESCRIPTION

Multiple electrical connection unit with LED indicators and safety circuit.  
 The unit can be equipped with solenoid valves series 340, 3/2NC and 3/2NO.  
 The solenoid valves can be assembled and tested on unit from 4 to 14 places.  
 The base has mutual inlets and mutual exhaust.  
 The user ports have quick connection for pipes  $\varnothing_{\text{ext}}$  4mm.  
 The energizing and de-energizing of the solenoid valves is showed by a LED indicator.

## FEATURES

Media :	Clean compressed air 20 $\mu$ m with or without lubricant	
Fixing method :	M4 screws	
Pneumatic connections :	G1/8" for inlet and exhaust, user ports by $\varnothing$ 4 quick connections	
Working pressure :	3/2NC	0,5÷10 bar
	3/2NA	0,5÷8 bar
Ambient temperature :	-10°C +50°C	
Protection class :	IP50	
Electrical connection :	9 poles SUB-D connector for units from 4 to 8 positions 15 poles SUB-D connector for units from 9 to 14 positions	

## CODE:

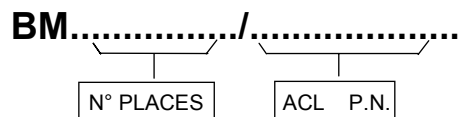

**NOTE: This product isn't standard. Please contact the manufacturer for any question**

## OVERALL DIMENSIONS

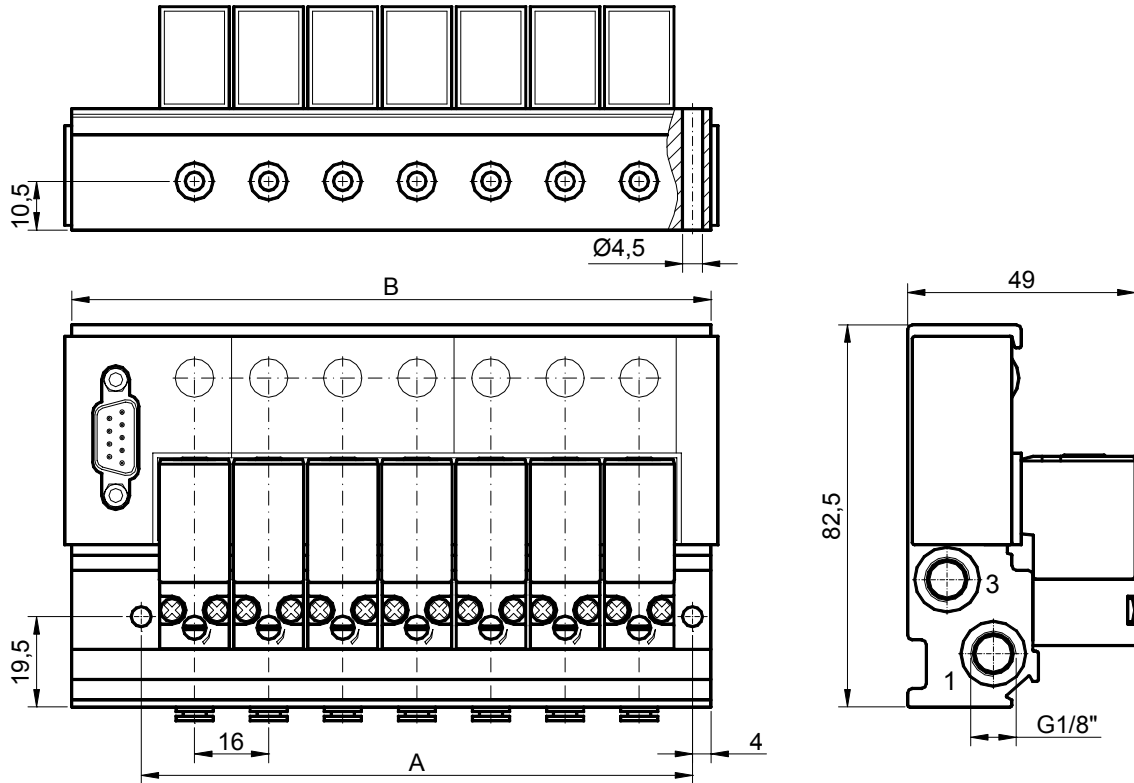

N° PLACES	4	5	6	7	8	9	10	11	12	13	14
A	71	87	103	119	135	151	167	183	199	215	231
B	93	109	125	141	157	173	189	205	221	237	253

## ELECTRICAL CONNECTION

### 4÷8 POSITIONS UNIT

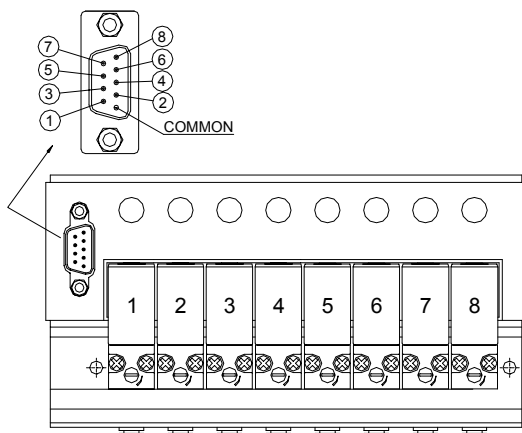

### 9 ÷ 14 POSITIONS UNIT

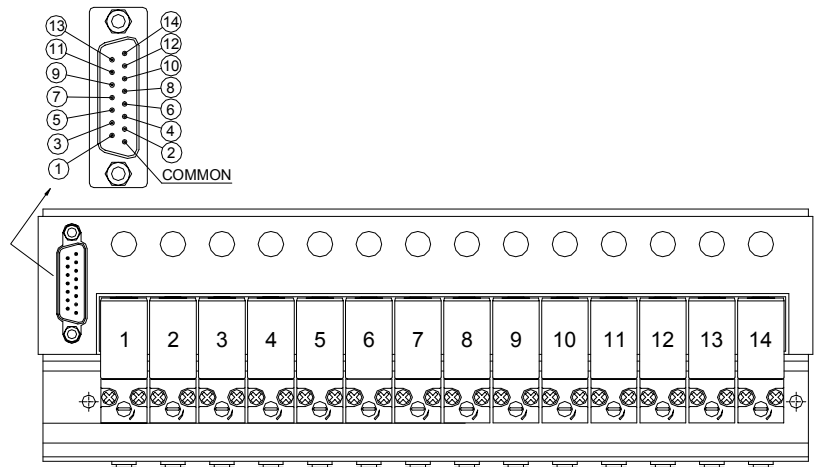

## Accessories for solenoid valve series 151 Cod. P40B – Hosetail DN4

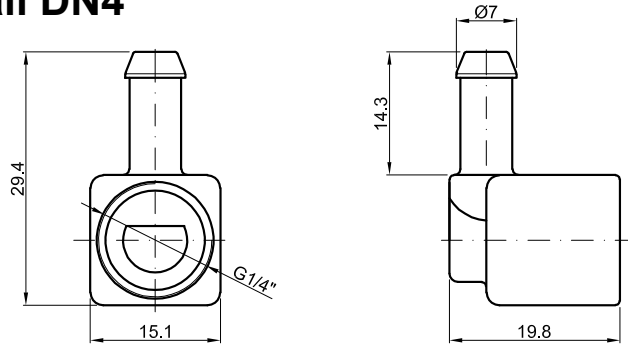

## Cod. P60B – Hosetail DN6

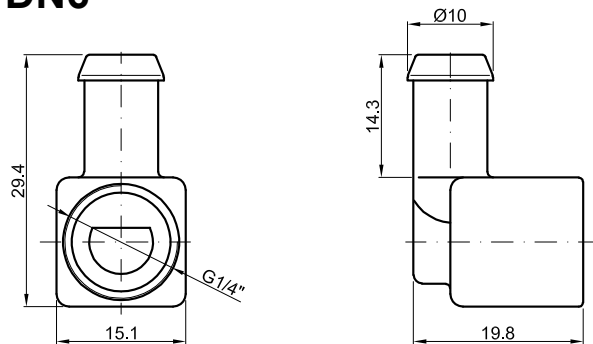

## Cod. VP40B – Hosetail DN4 with faucet

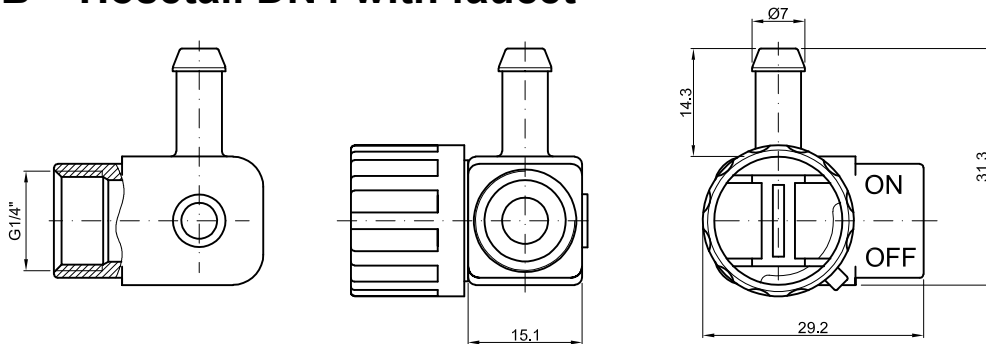

## Cod. VP60B – Hosetail DN6 with faucet

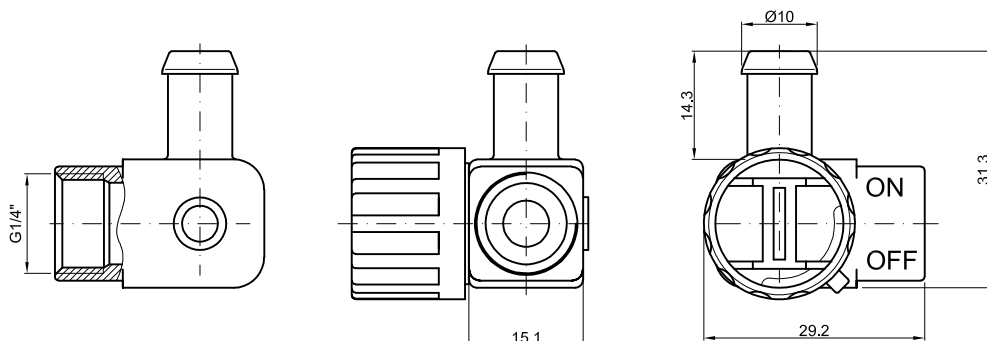



## 2/2 NC assisted lift diaphragm assembly

CODE	SEAL	VALVE SERIES
13428010	NBR	E108C E108D
13428040	EPDM	
13428020	FPM	
13429010	NBR	E108E
13429040	EPDM	
13429020	FPM	
13430010	NBR	E108F
13430040	EPDM	
13430020	FPM	

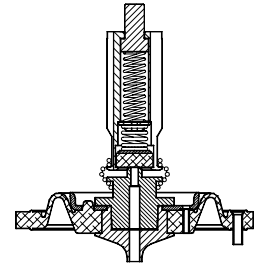

CODE	SEAL	VALVE SERIES
13431010	NBR	D108E
13431040	EPDM	
13431020	FPM	
13432010	NBR	D108F
13432040	EPDM	
13432020	FPM	

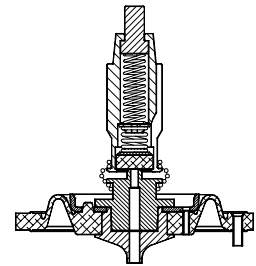

## 2/2 NC and NO servo-assisted diaphragm assembly

CODE	SEAL	VALVE SERIES
11030010	NBR	107B...10
11030040	EPDM	107C...10
11030020	FPM	207B...10 207C...10

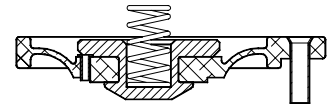

13386010	NBR	107C...12
13386040	EPDM	107D...12
13386020	FPM	207C...12 207D...12

13850010	NBR	107CB12/W 107DB12/W
----------	-----	------------------------

13395010	NBR	107E 207E
13395040	EPDM	
13395020	FPM	

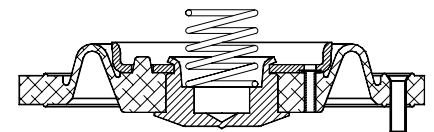

13402010	NBR	107F 207F
13402040	EPDM	
13402020	FPM	

11266010	NBR	107G 107H 207G 207H
11266040	EPDM	
11266020	FPM	

11267010	NBR	107I 207I
11267040	EPDM	
11267020	FPM	

12669010	NBR	107M 107R 207M 207R
----------	-----	------------------------------

13744010	NBR	107M.../W 107R.../W 207M.../W 207R.../W
----------	-----	--

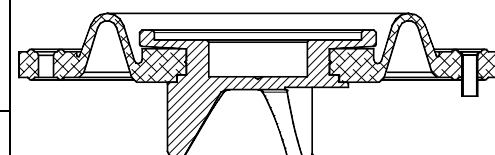

## 2/2 NO seal assembly for tube Ø10

CODE		SEAL	VALVE SERIES	
BRASS	S.STEEL		BRASS	S.STEEL
11166010	12104010	NBR EPDM FPM	205A	277C 277D 277E 277F
11166040	12104040		207C	
11166020	12104020		207D	
			207E	
			207F	
			212X	
			216X	
			218C	
			218D	

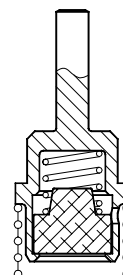

## 2/2 NO seal assembly for tube Ø13 (alternating current versions)

CODE		SEAL	VALVE SERIES	
BRASS	S.STEEL		BRASS	S.STEEL
11167010	12916010	NBR EPDM FPM	E206...15	210...15 210...20 210...25
11167040	12916040		E206...20	
11167020	12916020		E206...25	
			207G	
			207H	
			207I	
			207M	
			207R	
			E214X...15	
			E214X...20	
		E214X...25		
		219C...		
		219D...		
11176010	12003010	NBR EPDM FPM	E206...35	E210...35 E210...45 E210...52
11176040	12003040		E206...45	
11176020	12003020		E206...52	
			E214X...35	
			E214X...45	
			E214X...52	
12430010	13130010	NBR EPDM FPM	207M.../W	210...64
12430040	13130040		207R.../W	
12430020	13130020		206...64	

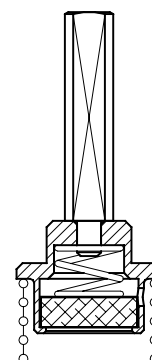

## 2/2 NO seal assembly for tube Ø13 (direct current versions)

CODE		SEAL	VALVE SERIES	
BRASS	S.STEEL		BRASS	S.STEEL
13754010	12916010	NBR EPDM FPM	D206...15/3	D210...15 D210...20 D210...25
13754020	12916040		D206...20/3	
13754040	12916020		D206...25/3	
			D214X...15/5	
			D214X...20/5	
			D214X...25/5	
13755010	13756010	NBR EPDM FPM	D206...35/3	D210...35/3 D210...45/3 D210...52/3
13755020	13756020		D206...45/3	
13755040	13756040		D206...52/3	
			D214X...35/5	
			D214X...45/5	

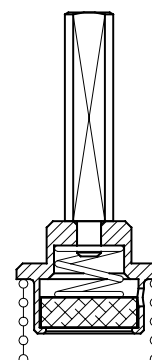



## 2/2 NC with dry armature diaphragm

CODE	SEAL	VALVE SERIES
10402030	SILICONE	150

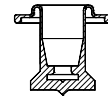

CODE	SEAL	VALVE SERIES
11315030	SILICONE	160 161

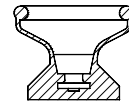

## Diverting valve with dry armature diaphragm

CODE	SEAL	VALVE SERIES
10644010	NBR	330

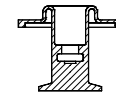

## Ø6.35 2/2 NC plunger

CODE	SEAL	VALVE SERIES
1046301A	NBR	121
1046304A	EPDM	
1046302A	FPM	

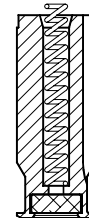

## Ø9 2/2 NC plunger

CODE	SEAL	VALVE SERIES
11799010	NBR	105
11799040	EPDM	135
11799020	FPM	107C – 107D – 107E – 107F
11799090	NBR DVGW	111
11799340	EPDM WRC	112
		116
*11800010	NBR	118
*11800040	EPDM	510
*11800020	FPM	512
*11800090	NBR DVGW	*105/135 (only Ø4)
*11800340	EPDM WRC	

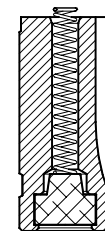

## 2/2 NC Ø11.85 plunger (up to orifice Ø5.2)

CODE	SEAL	VALVE SERIES
10120010	NBR	106A – 106B – 106C – 106D
10120040	EPDM	107G – 107H – 107I
10120020	FPM	114X
10120050	PTFE	119C – 119D
		610
10120N10	NBR	110B – 110C – 110D
10120N40	EPDM	
10120N20	FPM	

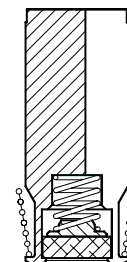

## 2/2 NC Ø11.85 plunger (orifice Ø6.4)

CODE	SEAL	VALVE SERIES
11035010	NBR	106B – 106C – 106D
11035040	EPDM	
11035020	FPM	110B – 110C – 110D
12004050	PTFE	

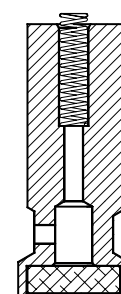

## 3/2 NC Ø9 plunger

CODE	SEAL	VALVE SERIES
10492010	NBR	305A DN1,2
10492040	EPDM	311A DN1,2
10492020	FPM	312X DN1,2
10519010	NBR	218B
10519040	EPDM	305A
10519020	FPM	335
		311A
		312X
		316X
		530
		532

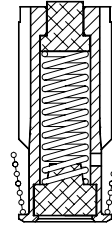

## 3/2 NO Ø9 plunger (inlet from the core)

CODE	SEAL	VALVE SERIES
11289010	NBR	305A
11289040	EPDM	311A
11289020	FPM	312X

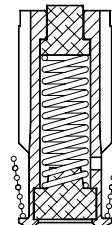

## 3/2 Ø9 plunger Universal Service (NC and NO)

CODE	SEAL	VALVE SERIES
11291010	NBR	305A
11291040	EPDM	311A
11291020	FPM	312X
		316X

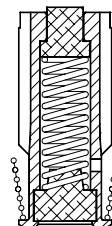

## 3/2 NC Ø11.85 plunger

CODE	SEAL	VALVE SERIES
10966010	NBR	203A
10966040	EPDM	306A
10966020	FPM	306B
		314X
		630
10966N10	NBR	310B
10966N40	EPDM	310C
10966N20	FPM	310D

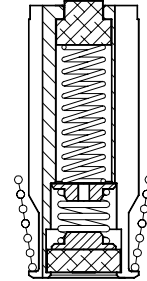

## 3/2 NO Ø11.85 plunger (inlet from the core)

CODE	SEAL	VALVE SERIES
11045010	NBR	306A
11045040	EPDM	306B
11045020	FPM	314X
11045N10	NBR	310B
11045N40	EPDM	310C
11045N20	FPM	310D

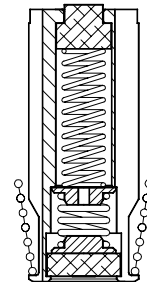

## 3/2 Ø11.85 plunger Universal Service (NC and NO)

CODE	SEAL	VALVE SERIES
11044010	NBR	306A
11044040	EPDM	306B
11044020	FPM	314X
11044N10	NBR	310B
11044N40	EPDM	310C
11044N20	FPM	310D

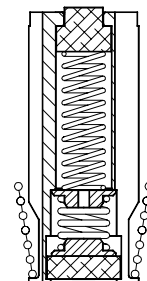

## 2/2 NC Ø11.85 plunger

CODE	SEAL	VALVE SERIES
10343010	NBR	109C 109D
10343040	EPDM	
10343020	FPM	
10344010	NBR	109E
10344040	EPDM	
10344020	FPM	

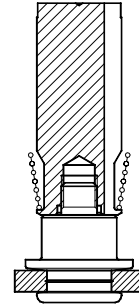

## 2/2 NC and NO piston assembly

CODE	SEAL	VALVE SERIES
12735000	FPM / PTFE	118C
		118D
		119C
		119D
		218C
		218D
		219C
		219D

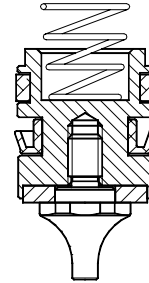

## 2/2 NC for steam up to 180°C piston assembly

CODE	SEAL	VALVE SERIES
11910000	PTFE	119W

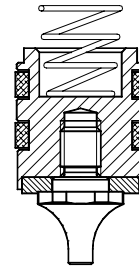

## 2/2 NC series 118-119 G1/4" piston assembly

CODE	SEAL	VALVE SERIES
11909000	PTFE	118B 119B

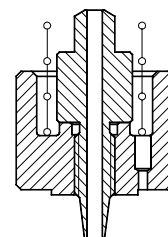

## 2/2 NC Ø10 brass armature tube for AC and DC

CODE	SEAL	VALVE SERIES
10128010	NBR	E105A
10128040	EPDM	E112X
10128020	FPM	E116X

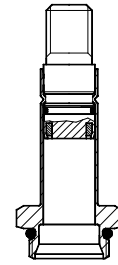

## 2/2 NC Ø10 stainless steel armature tube for AC and DC

CODE	SEAL	VALVE SERIES
10128SI10 10128SI40 10128SI20	NBR EPDM FPM	E107C - E177C
		E107D - E177D
		E107E - E177E
		E107F - E177F
		E111A
		E118C E118D

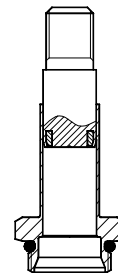

## 2/2 NC Ø10 electroless nickel-plated brass armature tube for AC and DC, flange fixing

CODE	SEAL	VALVE SERIES
11762K10	NBR DVGW	E135
11762K40	EPDM WRC	
11762K20	FPM	

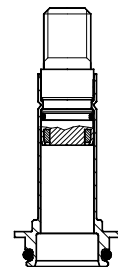

## 2/2 NC Ø10 brass armature tube for DC

CODE	SEAL	VALVE SERIES
10219010	NBR	D105A
10219040	EPDM	D112X
10219020	FPM	D116X

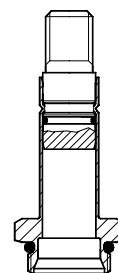

## 2/2 NC Ø10 stainless steel armature tube for DC

CODE	SEAL	VALVE SERIES
10219SI10 10219SI40 10219SI20	NBR EPDM FPM	D107C - D177C
		D107D - D177D
		D107E - D177E
		D107F - D177F
		D111A
		D118C D118D

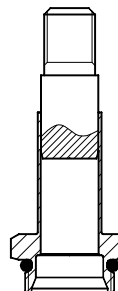

**3/2 NC Ø10 brass armature tube for AC and DC**  
**Hole Ø1**

CODE	SEAL	VALVE SERIES
10340210	NBR	E305A
10340240	EPDM	E312X
10340220	FPM	E316X

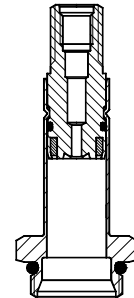

**3/2 NC Ø10 brass armature tube for AC and DC**  
**Hole Ø1.5**

CODE	SEAL	VALVE SERIES
10340010	NBR	E305A
10340040	EPDM	E312X
10340020	FPM	E316X

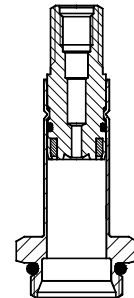

**3/2 NC Ø10 brass armature tube for AC and DC**  
**Hole Ø1.7**

CODE	SEAL	VALVE SERIES
10340110	NBR	E305A
10340140	EPDM	E312X
10340120	FPM	E316X

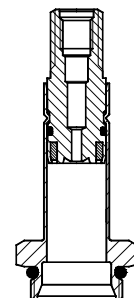

**3/2 NC Ø10 brass armature tube for DC**  
**Hole Ø1**

CODE	SEAL	VALVE SERIES
10341210	NBR	D305A
10341240	EPDM	D312X
10341220	FPM	D316X

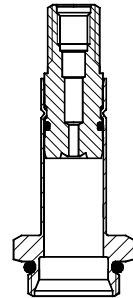

**3/2 NC Ø10 brass armature tube for DC**  
**Hole Ø1.5**

CODE	SEAL	VALVE SERIES
10341010	NBR	D305A
10341040	EPDM	D312X
10341020	FPM	D316X

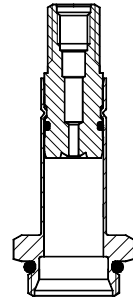

**3/2 NC Ø10 brass armature tube for DC**  
**Hole Ø1.7**

CODE	SEAL	VALVE SERIES
10341110	NBR	D305A
10341140	EPDM	D312X
10341120	FPM	D316X

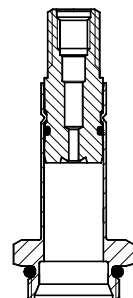

### 3/2 NC Ø10 stainless steel armature tube for AC and DC Hole Ø1

CODE	SEAL	VALVE SERIES
10340SI210	NBR	E305A
10340SI240	EPDM	E311A *
10340SI220	FPM	E312X
		E316X

\* For silver shading ring versions contact the manufacturer

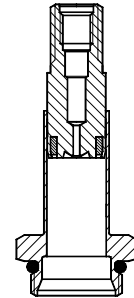

### 3/2 NC Ø10 stainless steel armature tube for AC and DC Hole Ø1.5

CODE	SEAL	VALVE SERIES
10340SI010	NBR	E305A
10340SI040	EPDM	E311A *
10340SI020	FPM	E312X
		E316X

\* For silver shading ring versions contact the manufacturer

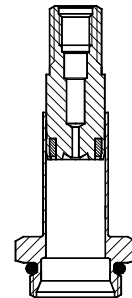

### 3/2 NC Ø10 stainless steel armature tube for AC and DC Hole Ø1.7

CODE	SEAL	VALVE SERIES
10340SI110	NBR	E305A
10340SI140	EPDM	E311A *
10340SI120	FPM	E312X
		E316X

\* For silver shading ring versions contact the manufacturer

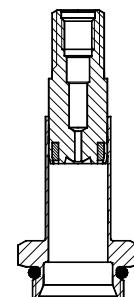



**3/2 NC Ø10 stainless steel armature tube for DC  
Hole Ø1**

CODE	SEAL	VALVE SERIES
10341SI210	NBR	D305A
10341SI240	EPDM	D311A
10341SI220	FPM	D312X
		D316X

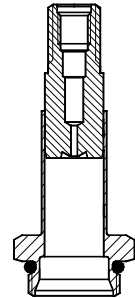

**3/2 NC Ø10 stainless steel armature tube for DC  
Hole Ø1.5**

CODE	SEAL	VALVE SERIES
10341SI10	NBR	D305A
10341SI40	EPDM	D311A
10341SI20	FPM	D312X
		D316X

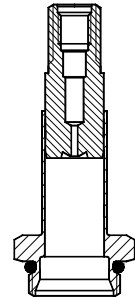

**3/2 NC Ø10 stainless steel armature tube for DC  
Hole Ø1.7**

CODE	SEAL	VALVE SERIES
10341SI110	NBR	D305A
10341SI140	EPDM	D311A
10341SI120	FPM	D312X
		D316X

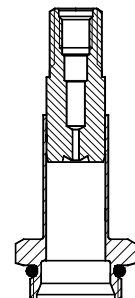

## 2/2 NC Ø13 stainless steel armature tube for AC and DC

CODE	SEAL	VALVE SERIES
12456010	NBR	E106A
12456040	EPDM	E106B
12456020	FPM	E107G
		E107H
		E107I
		E107M
		E107R
		E108
		E109
		E110 *
		E114
		E119
		E320

\* For silver shading ring versions contact the manufacturer

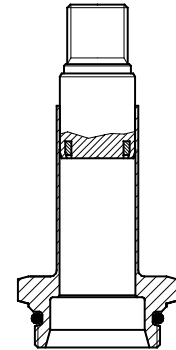

## 2/2 NC Ø13 stainless steel armature tube for DC

CODE	SEAL	VALVE SERIES
12457010	NBR	D106A
12457040	EPDM	D106B
12457020	FPM	D107G
		D107H
		D107I
		D107M
		D107R
		D108C
		D108D
		D109
		D110
		D114
		D119
		D320

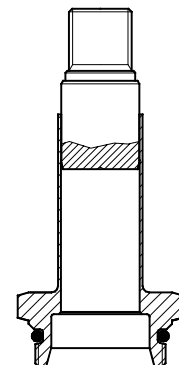

## 2/2 NC Ø13 stainless steel armature tube for 108 G3/4" and G1" DC

CODE	SEAL	VALVE SERIES
12465010	NBR	D108E
12465040	EPDM	D108F
12465020	FPM	

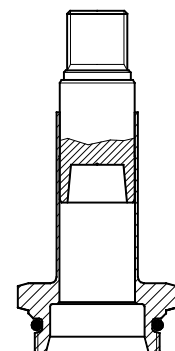

**3/2 NC Ø13 stainless steel armature tube for AC and DC  
Hole Ø2**

CODE	SEAL	VALVE SERIES
12464110	NBR	E306A
12464140	EPDM	E306B
12464120	FPM	E310 *
		E314X

\* For silver shading ring versions contact the manufacturer

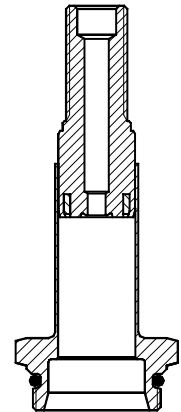

**3/2 NC Ø13 stainless steel armature tube for AC and DC  
Hole Ø2.4**

CODE	SEAL	VALVE SERIES
12464010	NBR	E306A
12464040	EPDM	E306B
12464020	FPM	E310 *
		E314X

\* For silver shading ring versions contact the manufacturer

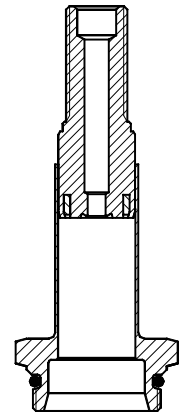

**3/2 NC Ø13 stainless steel armature tube for AC and DC  
Hole Ø2.8**

CODE	SEAL	VALVE SERIES
12464210	NBR	E306A
12464240	EPDM	E306B
12464220	FPM	E310 *
		E314X

\* For silver shading ring versions contact the manufacturer

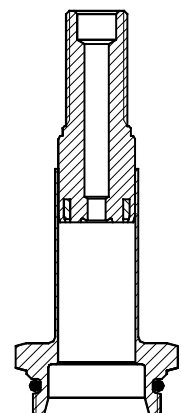

**3/2 NC Ø13 stainless steel armature tube for DC  
Hole Ø2**

CODE	SEAL	VALVE SERIES
12462110	NBR	D306A
12462140	EPDM	D306B
12462120	FPM	D310
		D314X

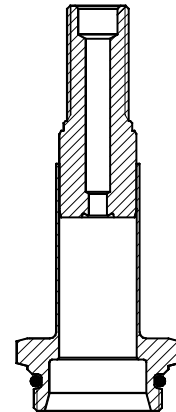

**3/2 NC Ø13 stainless steel armature tube for DC  
Hole Ø2.4**

CODE	SEAL	VALVE SERIES
12462010	NBR	D306A
12462040	EPDM	D306B
12462020	FPM	D310
		D314X

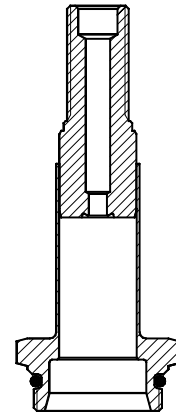

**3/2 NC Ø13 stainless steel armature tube for DC  
Hole Ø2.8**

CODE	SEAL	VALVE SERIES
12462210	NBR	D306A
12462240	EPDM	D306B
12462220	FPM	D310
		D314X

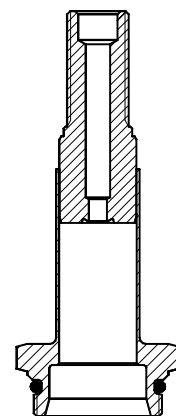

## 2/2 NO Ø10 brass armature tube for AC and DC

CODE	SEAL	VALVE SERIES
11170010	NBR	E205A
11170040	EPDM	E212X
11170020	FPM	E216X
		E218C
		E218D

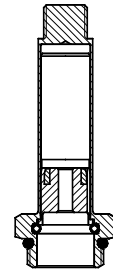

## 2/2 NO Ø10 brass armature tube for DC

CODE	SEAL	VALVE SERIES
11171010	NBR	D205A
11171040	EPDM	D212X
11171020	FPM	D216X
		D218C
		D218D

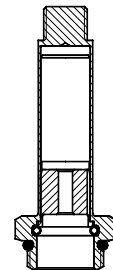

## 2/2 NO Ø10 stainless steel armature tube for AC and DC

CODE	SEAL	VALVE SERIES
11170Si10	NBR	E205A
11170Si40	EPDM	E207C - E277C
11170Si20	FPM	E207D - E277D
		E207E - E277E
		E207F - E277F
		E212X
		E216X
		E218C
		E218D

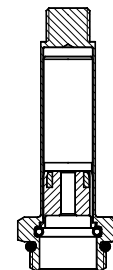

## 2/2 NO Ø10 stainless steel armature tube for DC

CODE	SEAL	VALVE SERIES
11171Si10	NBR	D205A
11171Si40	EPDM	D207C - D277C
11171Si20	FPM	D207D - D277D
		D207E - D277E
		D207F - D277F
		D212X
		D216X
		D218C
		D218D

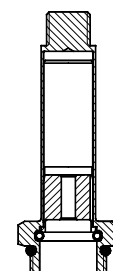

## 3/2 NO Ø10 brass armature tube for AC and DC

CODE	SEAL	VALVE SERIES
11174010	NBR	E307A
11174040	EPDM	E312X
11174020	FPM	E317X

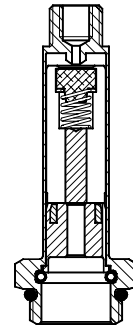

## 3/2 NO Ø10 brass armature tube for DC

CODE	SEAL	VALVE SERIES
11175010	NBR	D307A
11175040	EPDM	D312X
11175020	FPM	D317X

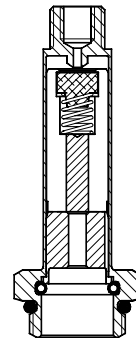

## 2/2 NC Ø7 brass armature tube for DC

CODE	SEAL	VALVE SERIES
10448010	NBR	D121L
10448040	EPDM	
10448020	FPM	

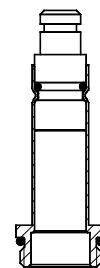

## 2/2 NO Ø13 brass armature tube for AC and DC

CODE	SEAL	VALVE SERIES
11172010 11172040 11172020	NBR EPDM FPM	E206A E206B E214X E207G E207H E207I E207M E207R E219C E219D

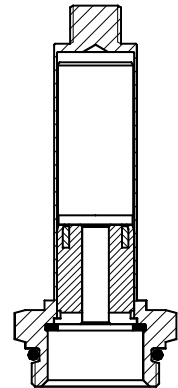

## 2/2 NO Ø13 brass armature tube for DC

CODE	SEAL	VALVE SERIES
11173010 11173040 11173020	NBR EPDM FPM	D206A D206B D214X D207G D207H D207I D207M D207R D219C D219D

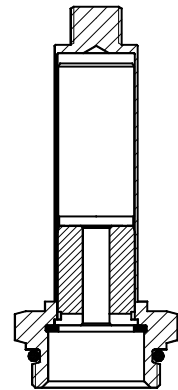

## 2/2 NO Ø13 stainless steel armature tube for AC and DC

CODE	SEAL	VALVE SERIES
11172SI10 11172SI40 11172SI20	NBR EPDM FPM	E206A E206B E210 E214X E207G E207H E207I E207M E207R E219C E219D

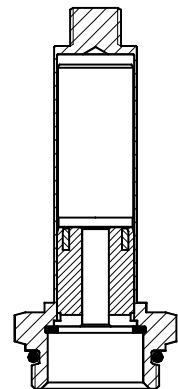

## 2/2 NO Ø13 stainless steel armature tube DC

CODE	SEAL	VALVE SERIES
11173SI10 11173SI40 11173SI20	NBR EPDM FPM	D206A D206B D210 D214X D207G D207H D207I D207M D207R D219C D219D

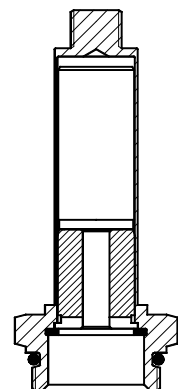

---

**COIL FIXING NUT**

---

**Code 10203000**  
**Coil fixing nut for series 3 and series 4**  
**2/2NC and 3/2NC solenoid valves**  
**with brass tube**

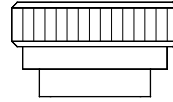

---

**Code 11643K0A**  
**Coil fixing nut for series 3 and series 4**  
**2/2NC and 3/2NC solenoid valves**  
**with stainless steel tube**

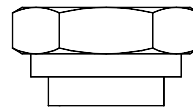

---

**Code 1012600B**  
**Coil fixing nut for series 3 and series 4**  
**2/2NO and 3/2NO solenoid valves**

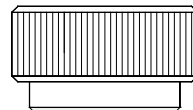

---

**Code 10097000**  
**Coil fixing nut for series 2 and series 5**  
**2/2NC and 3/2NC solenoid valves**

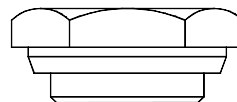

---

**Code 10293000**  
**Coil fixing nut for series 2 and series 5**  
**2/2NO solenoid valves**

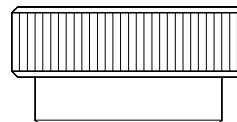

---

**Code 10464000**  
**Coil fixing nut for series 6**









**ACL S.r.l.**

20873 Cavenago di Brianza (MB) Italy Via Giovanni Falcone,6 Tel. +39 02 9501335 Fax +39 02 95 335041 E-mail: [infoacl@acl.it](mailto:infoacl@acl.it) <http://www.acl.it>



Organization management system  
certified according to ISO 9001:2008